

# INGO MAURER NOW



*INGO MAURER*



Dedicated to unforgettable Jenny Lau.

I. M.



Hängelampen / Hanging lamps / Suspensions / Lampade a sospensione

- 48 T.T. Moon LED
- 52 Brick LED
- 56 Luminophor LED
- 62 Light Structure LED
- 65 Light Structure Three LED
- 66 One New Flame LED
- 67 Flying Flames LED
- 72 Birdie's Ring
- 74 Da + Dort
- 76 Zufall
- 77 Silly-Kon LED
- 78 Johnny B. Butterfly
- 79 J. B. Schmetterling
- 80 Lucetto
- 81 Johnny B. Good
- 82 Alizz C. Cooper
- 84 Metall C. Cooper
- 86 Wo bist du, Edison, ...?
- 88 Eddie's Son
- 90 Oh Man it's a Ray!
- 92 ManOMan
- 94 Lacrime del Pescatore
- 96 Birds Birds Birds
- 97 Birdie
- 100 Pierre ou Paul
- 101 XXL Dome
- 104 Oh Mei Ma LED
- 105 Oh Mei Ma Weiss LED
- 106 Oh Mei Ma Kabir LED
- 106 Oh Mei Ma Kabir Weiss LED
- 110 Zettel'z Viva l'Italia
- 112 Zettel'z 6
- 112 Zettel'z 5
- 114 24 Karat Blau
- 115 24 Karat Blau M
- 118 Hot Achille
- 120 Schlitz
- 122 Canned Light
- 124 Campari Light
- 126 Max. Up & Down LED
- 127 Öff Öff
- 128 aTool
- 130 Max. Mover
- 132 Five Pack
- 134 Fly Candle Fly!
- 136 Porca Miseria!
- 138 Tu-Be I
- 139 Tu-Be Lüster
- 140 Knitterling LED
- 141 Maru LED
- 142 Floatation LED
- 146 Willydilly LED
- 148 Willydilly Bon LED
- 150 Savoie
- 151 Grasl



Tischlampen / Table lamps / Lampes de table / Lampade da tavolo

- 154** What we do Counts **LED**
- 156** I Ricchi Poveri Bzzzz
- 160** I Ricchi Poveri Five Butterflies
- 164** I Ricchi Poveri Toto
- 168** I Ricchi Poveri Monument for a Bulb
- 170** I Ricchi Poveri Fly **LED**
- 174** Lucellino **LED**
- 178** Oh·LED·One **OLED**
- 180** Dew Drops Table **LED**
- 184** Bastardo **LED**
- 188** Light Structure **LED**
- 189** Light Structure Three **LED**
- 190** My New Flame **LED**
- 194** Knot 1 **LED**
- 196** Knot 2 **LED**
- 197** Knot 3 **LED**
- 198** LED's Oskar **LED**
- 199** Oskar
- 201** Kuddelmuddel
- 202** Zak Zarak **LED**
- 204** Looksoflat **LED**
- 206** Bulb
- 208** Lucellino
- 210** Birdie's Busch
- 212** Alizz T. Cooper
- 213** Metall T. Cooper
- 214** Zufall **LED**
- 216** Jetzt **LED**
- 218** Max. Kugler **LED**
- 220** Mozzkito
- 222** Campari Bar
- 224** Veramente al Dente **LED**
- 226** HOT.HOT
- 228** Delirium Yum
- 229** Lampampe **LED**
- 232** Bibibibi **LED**
- 233** Don Quixote
- 234** 24 Karat Blau T
- 235** Seven Rats
- 236** Grasl
- 237** One From The Heart



Stehlampen / Floor lamps / Lampadaires / Lampade a stelo

- 240** Dew Drops Floor **LED**
- 244** Max. Floor **LED**
- 250** Bastardo Floor **LED**
- 254** Ilios
- 256** Metall F. Cooper
- 257** Alizz F. Cooper
- 260** Swingading
- 262** Knüller
- 264** Stand Up For Your Light



Deckenlampen / Ceiling lamps / Plafonniers / Lampade da soffitto

- 268** Birdie's Nest
- 270** Luxury Pure **LED**
- 271** Lil Luxury **LED**
- 274** Spock
- 275** Sista
- 276** Zuuk
- 278** Lampeduso
- 279** Tooling
- 280** Use Me C.
- 282** Light Cone **LED**
- 283** Schlitz Up **LED**
- 285** Light Cone S **LED**
- 285** Light Cone S vertical **LED**



Wandlampen / Wall lamps / Appliques / Lampade da parete

- 292** Dew Drops Wall **LED**
- 294** Lucellino
- 295** Lucellino NT
- 296** Seven off the Wall
- 298** Holonzki
- 299** Dead Bulb Alive
- 300** Oskar
- 302** LED's Oskar
- 304** zero · one
- 305** Aka\_Tsuki
- 306** Use Me W.
- 307** Wandering Finger Wall
- 308** Delight **LED**
- 310** Light au Lait
- 311** Canned Light
- 312** Max.Wall **LED**
- 313** Tooling
- 314** Max. Mover



The MaMo Nouchies

- 321** Kokoro
- 322** Wo-Tum-Bu 1, 2, 3
- 325** Con-Qui
- 326** Jimken
- 327** Ysmen
- 328** Poul Poul
- 329** Samurai
- 330** Mahbruky
- 331** The Tribe: Watapunga
- 332** Gaku



## LED + OLED + Specials

- 339** Bellissima Brutta **LED**
- 340** Stardust **LED**
- 341** Licht.Enstein **LED**
- 342** LED Bench **LED**
- 344** LED Table **LED**
- 346** Lüster **LED**
- 348** El.E.DEE **LED**
- 350** One Thousand and One Lights **LED**
- 351** LED Paravent **LED**
- 352** Rose, Rose on the Wall ... **LED**
- 354** LED Wallpaper **LED**
- 356** Hoi Polloi **LED**
- 358** Oh·LED·One **OLED**
- 360** Whisper Wind **OLED**
- 362** Early Future **LED**
- 363** Flying Future **LED**
- 364** Double C. Future **OLED**
- 363** Double T. Future **OLED**
- 367** 4 x 4 is 34 **OLED**



## Systeme / Systems / Système / Sistemi

- 370** YaYaHo
- 374** Element 14
- 375** Element 16
- 376** Element 6 + 3
- 377** Element 1 + 77
- 378** Element 4 + 5
- 379** Element 2 + Spiegel/Mirror/Miroir/Specchio
- 388** BaKaRú





## Zeichenerklärung / Signs and symbols / Légende / Simboli e descrizione



Leuchtmittel / Light source / Agent lumineux / Lampada.



Fassung / Socket / Douille / Attacco.



Mit eingebauten LEDs. Die Leuchtmittel können nicht vom Nutzer ausgetauscht werden. / With built-in LEDs. The light source is not exchangeable by the user. / Livré avec LED intégrés. Les ampoules LED ne peuvent pas être changées par l'utilisateur. / Munito di LED integrate. Il modulo LED non può essere sostituito dall'utente.



Mit elektronischem Transformator mit Schieberegler. / With electronic transformer with dimmer. / Avec transformateur électronique à curseur. / Con trasformatore elettronico con variatore lineare.



Mit integriertem Transformator. / With built-in transformer. / Avec transformateur intégré. / Con trasformatore integrato.



Mit Steckertransformator. / With plug-in transformer. / Avec transformateur à pris. / Con trasformatore a spina.



Kabellänge / Cable length / Longueur du câble / Lunghezza cavo.



Neuheit/Prototyp. Entwicklung bei Drucklegung noch nicht abgeschlossen. Aktuelle und vollständige Angaben finden Sie auf unserer Website [www.ingo-maurer.com](http://www.ingo-maurer.com) / Novelty/Prototype, development not finalised at time of printing. Up-to-date and complete details on our website [www.ingo-maurer.com](http://www.ingo-maurer.com) / Nouveauté/Prototyp: développement encore inachevé au moment de la mise en impression. Toutes les données actuelles et complètes sont sur notre site web [www.ingo-maurer.com](http://www.ingo-maurer.com) / Novità/Prototipo. In fase di sviluppo al momento della stampa. Informazioni aggiornate e complete disponibili sul nostro sito [www.ingo-maurer.com](http://www.ingo-maurer.com)

Alle Maßangaben in Zentimetern / All dimensions in centimeters /  
Toutes dimensions en centimètres / Tutte le misure in centimetri



## **Destination Munich – Kaiserstrasse 47**

Peter Groom

In December 2008, a new space opened in Munich – the showroom of world-renowned lighting designer, Ingo Maurer, where for the first time in Europe **“studioshowroomwerkstattatelier”** makes discovering Ingo Maurer prototypes, One-Offs, and entire lighting collection possible at one unique address. Situated just off a central courtyard marked by a giant 4.5 m high Water Column, you will find a secret garden where the entrance to the showroom awaits, and the glass doors part to welcome you to experience more than 130 products. Such a significant body of work in this well thought out setting creates a truly special experience for everyone.

The showroom is open to the public year round at Kaiserstrasse 47 in Munich. It is a place that allows for productive contemplation,





open dialogue, discussions, as well as technical explanations, but principally makes it possible to purchase lamps from the wide range of products on display. "This is a place to come where you can set your imagination free," says Ingo Maurer, "each experience is intended to be unique and we look forward to making this a reality for each and every visitor."

On first impression, the impact of the creative energy in the product is immediate and each light is placed in a way to allow you to indulge



your curiosity and learn more about this poet and magician of light. It is also a setting to obtain a deeper understanding about the High-Tech and “Manufaktur” aspects of Ingo Maurer products, along with an opportunity to take advantage of expert client services, schedule an appointment to discuss custom orders, obtain in-depth product knowledge or advice on project planning.

“To communicate the aesthetic and functional potential of a lamp, it’s best to have it where we have control of the environment it is in.



The customer can see both the lamp and the light it creates, as well as try out how it works,” Ingo Maurer explains. “We have learned this consistently from the tradeshows, fairs and at our showroom in New York. We are looking forward to transferring this knowledge into the experience at Kaiserstrasse.”



The effort to transfer a broader understanding of the product is present in every detail put into the showroom and as Ingo Maurer further articulates, "My wish for the new space on Kaiserstrasse is that it will allow the visitor to recognize our enthusiasm for the unique value of original lighting and inspire them to see more than just a lighting fixture. Our passion to create is very strong, and to



share this openly was the principal motivation for us to open this space.” Well worth a special trip to Munich, the opportunity to explore over 40 years of Ingo Maurer product design, both past and present, makes this most certainly a “not to be missed” design destination.

**studioshowroomwerkstattatelier+shop**

Kaiserstrasse 47, 80801 Munich, Germany, Phone: +49 89 381 60 691,  
Fax: +49 89 381 60 690, Email: [space@ingo-maurer.com](mailto:space@ingo-maurer.com),  
[www.ingo-maurer.com](http://www.ingo-maurer.com)









To the man who started it all,  
Thomas Alva Edison





## **Our Shop in New York**

“89 Grand Street has been our home since 1999. I have always felt welcomed with open arms. New York is a place of possibilities, free and open. It makes me happy that I am part of it.”

I.M.





Ingo Maurer LLC 89 Grand Street New York, NY 10013 Tel. 212 965 8817  
Fax 212 965 8819 [making-light@ingomaurer-usa.com](mailto:making-light@ingomaurer-usa.com) [www.ingo-maurer.com](http://www.ingo-maurer.com)







Comic Explosion, 2010.  
Made on commission, size and colours variable.



**... and we do projects.**



Model for redesign of U-Bahnhof Münchner Freiheit, Munich, renovation completed late 2009.

Our presentation models are a mix of playful imagination and precise design. We create them carefully to define and convey our vision for your project.



Our concept for Marienplatz subway station in Munich, created in partnership with Allmann Sattler Wappner Architects. Unanimously chosen as winner of the competition to redesign the mezzanine level in January 2011. Construction will be completed in autumn 2015.





Rendering for Machane Yehuda Market, Jerusalem.

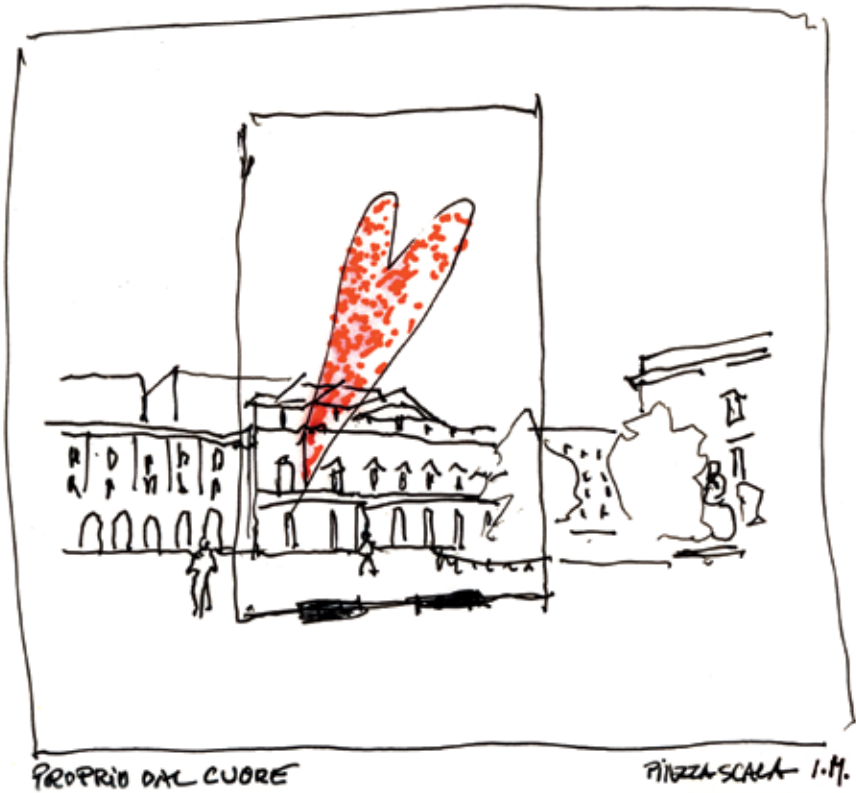



Lighting concept for an industrial landmark,  
Luxembourg, 2014.









Lighting concept for the disused blast furnaces in Esch-Belval, Luxembourg, realised in 2014.





Ablaze – an installation by Ingo Maurer and Axel Schmid for Interni's Mutant Architecture exhibition at Cortile della Farmacia, Milano 2011, sponsored by ENEL.





Broken Egg, Inhotim Brazil

A dream on the way to be realised in Brazil for the Inhotim Art Park. Thank you, Bernardo Paz!















*Beyond Design*® by Ingo Maurer

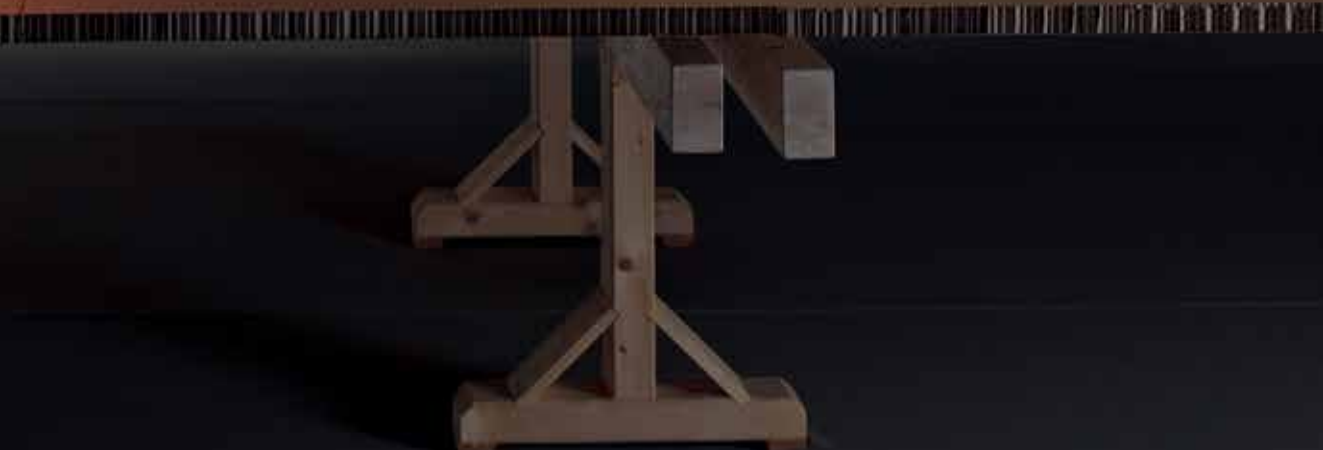

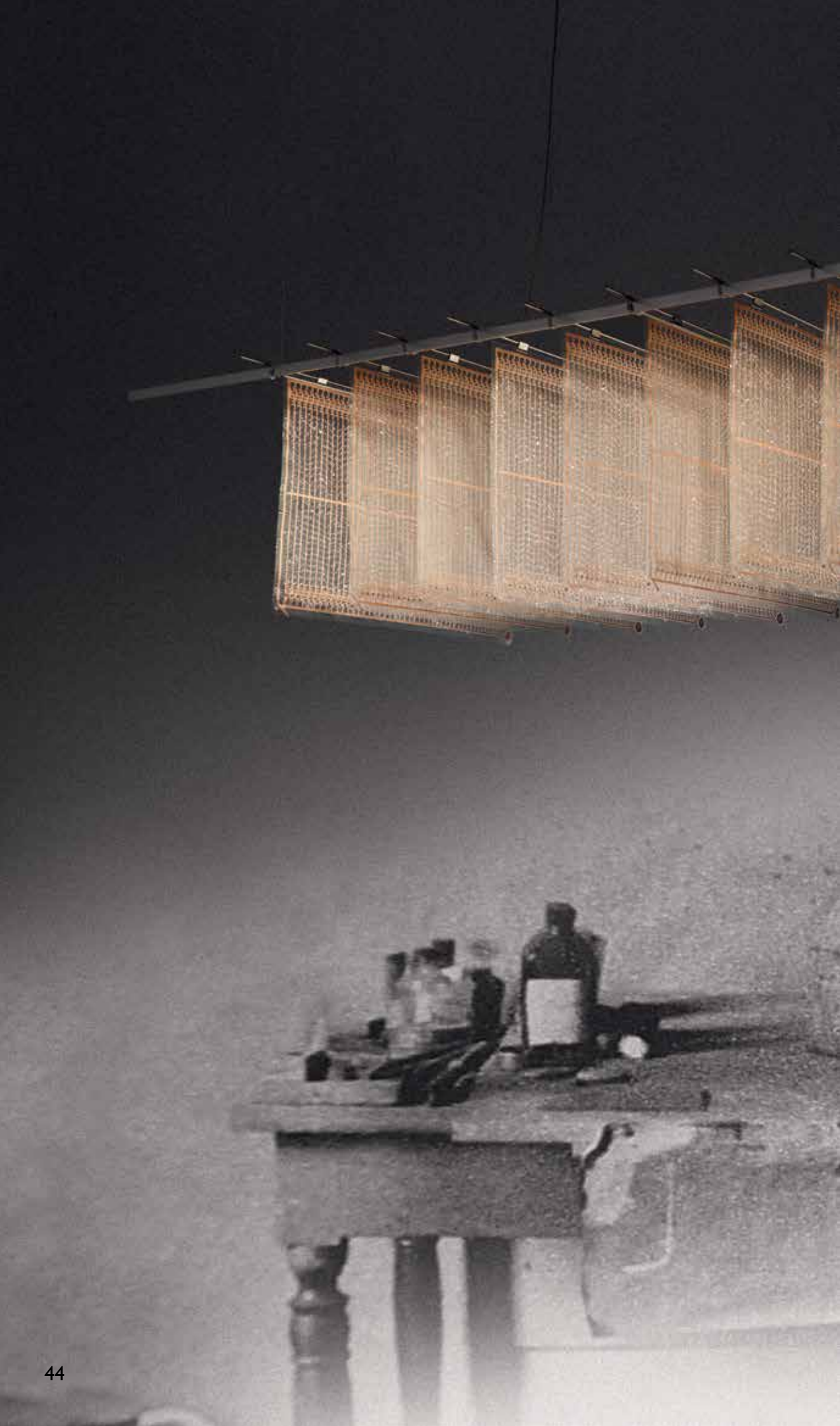



**Dew Drops Suspension**







Hängelampen / Hanging lamps / Suspensions / Lampade a sospensione







**T.T. Moon**  
**still a mystery**  
**in the clouds**  
**but soon**  
**a real**  
**suspension light**  
**with advanced**  
**technique.**  
**Frei von**  
**Designzwängen.**



**Brick,  
a LED system.  
Multifunctional  
for office, kitchen,  
privat desk.  
Illuminating spaces.  
Dimmable.**



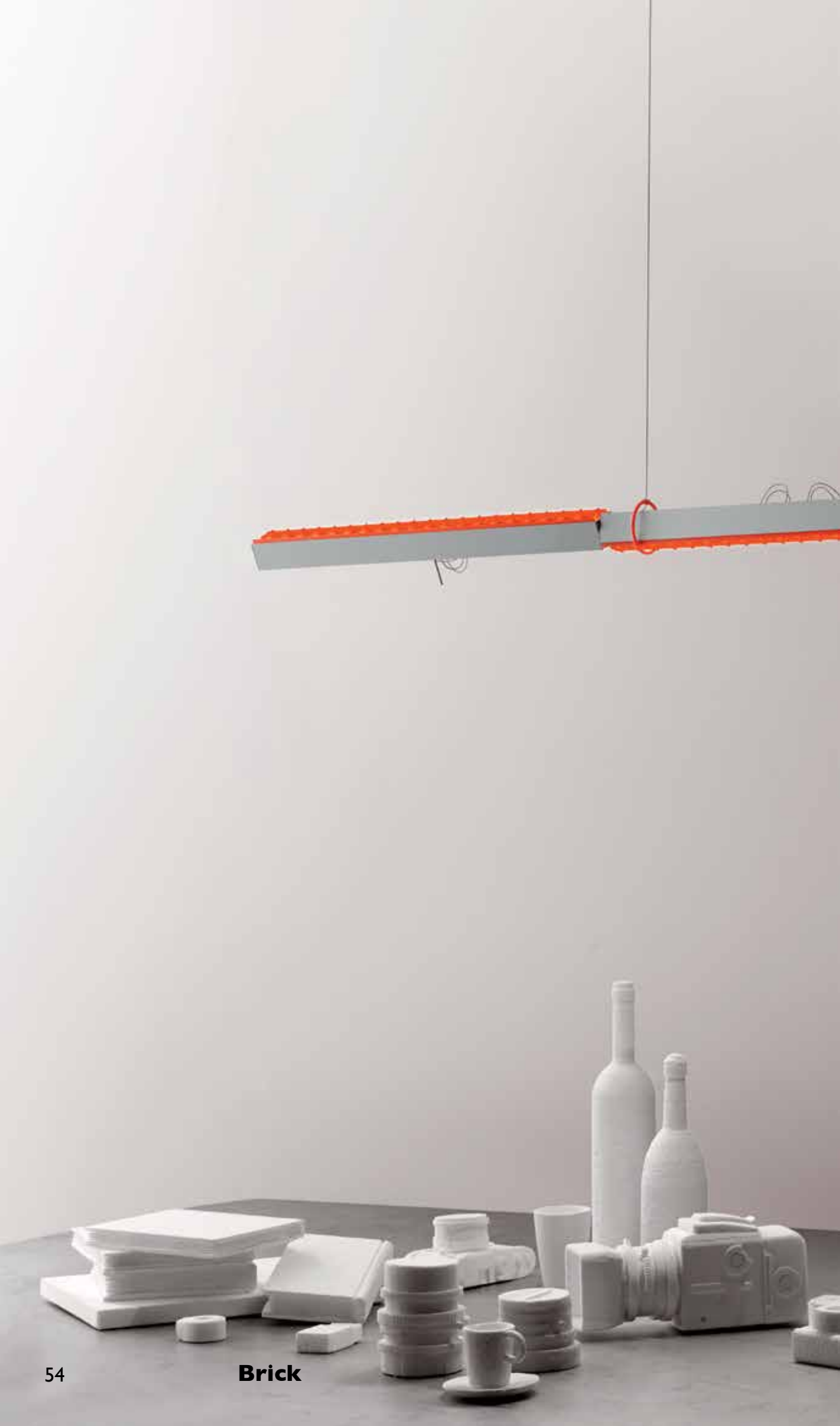



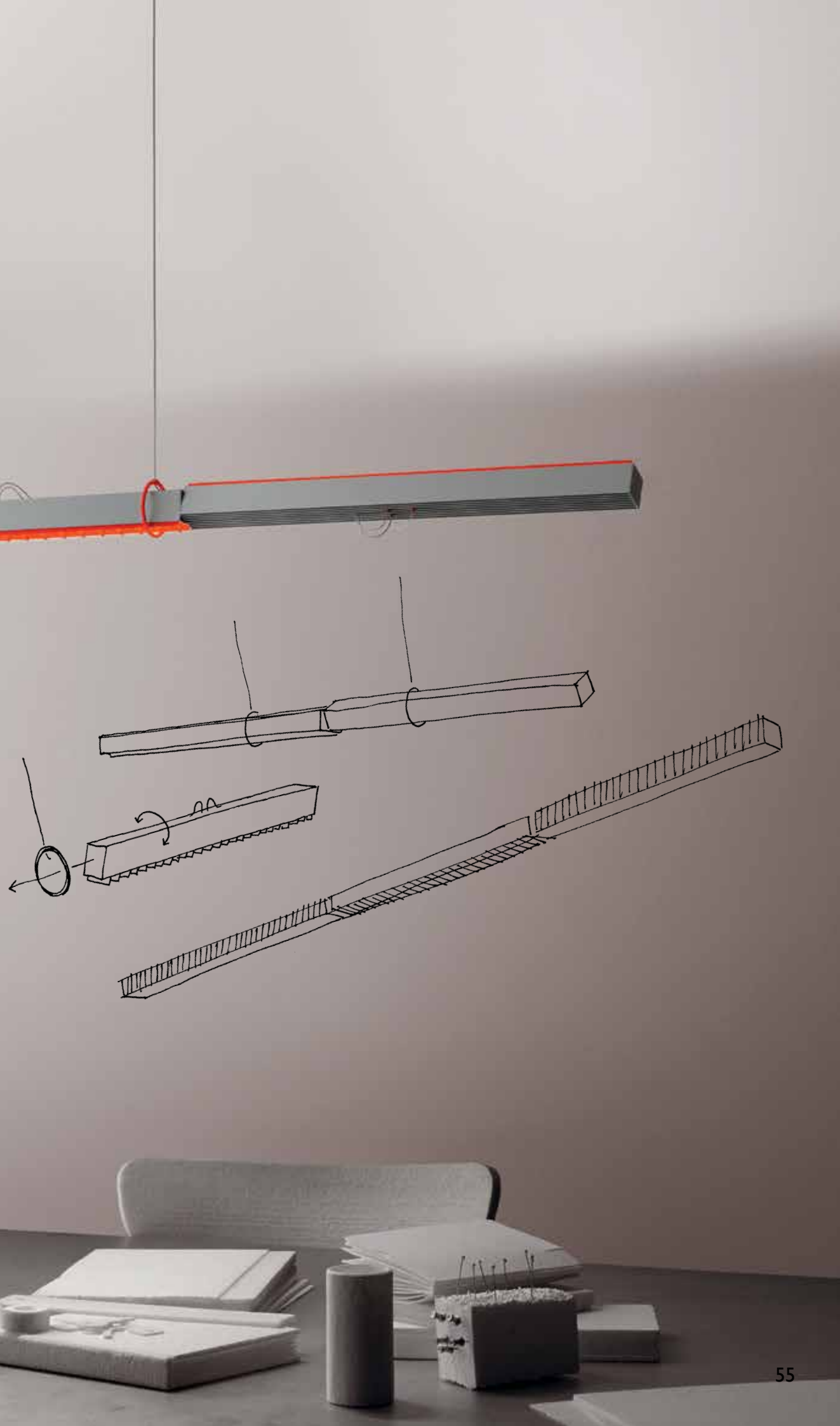

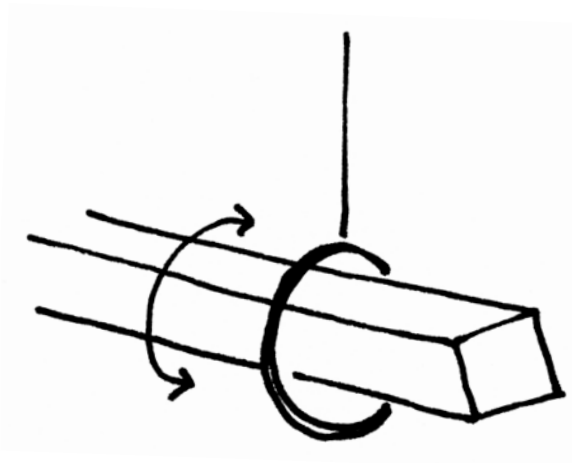

**Upside down**

**Brick, you turn me**

**inside out and round**

**and round**

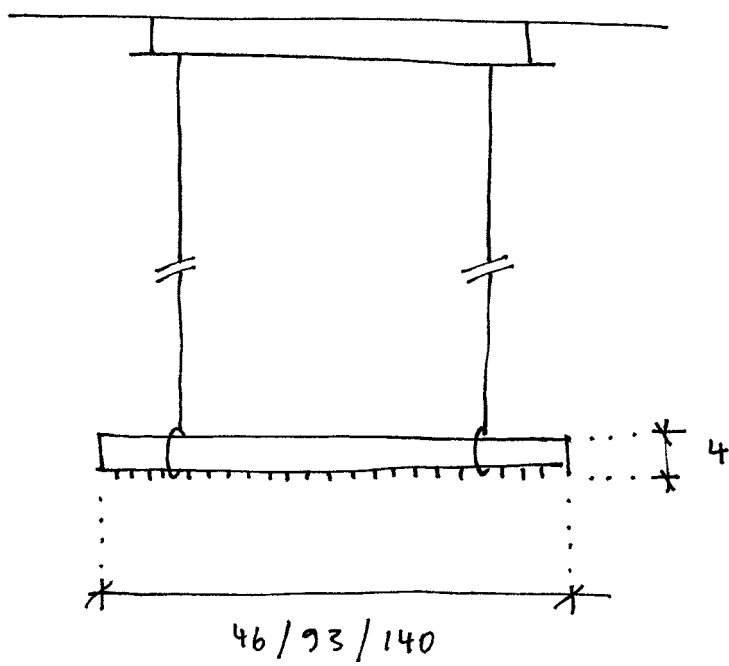

**Brick Plus**

**Brick Base**

**Brick Plus**

# **A bright new multi-functional multi-purpose lighting system. Design: Team\* work at its best!**

\*Special Thanks to Sebastian Hepting

## **Brick Ingo Maurer Team 2013**

Eloxiertes Aluminium, pulverbeschichtetes Metall, Kunststoff. Brick Base kann einzeln oder in Kombination mit ein oder zwei Brick Plus, dem Zusatzelement, verwendet werden. Die Elemente sind einzeln um 360° drehbar und können sowohl als Uplight als auch als Downlight verwendet werden. Stufenlos dimmbar durch Sensorschalter mit Memofunktion. Leuchtenkörper in Schwarz, Blau oder Aluminium Natur. Lamellenblende in Leuchtröt, Leuchtgelb oder Silber. Kombinieren Sie die Farben nach Ihren Wünschen! Mit Vorschaltgerät und eingebauten LEDs.

Anodised aluminium, power-coated metal, plastic. Brick Base can be used single or in combination with up to two additional Brick Plus elements. The elements rotate through 360° and can serve both as up- or downlight. Touch dimmer with memo function. Elements in black, blue or aluminium. Diffusor in fluorescent red, yellow or silver. Combine elements and diffusors as you wish! With electronic ballast and integrated LEDs.

Aluminium anodisé, métal avec revêtement par poudre, matière plastique. Brick Base peut être utilisée comme simple élément ou on peut ajouter jusqu'à deux éléments supplémentaires Brick Plus. Les éléments ont une rotation de 360° et peuvent être utilisés au choix comme up-light ou downlight. Touchdimmer avec fonction de mémoire. Eléments en noir, bleu ou aluminium. Diffuseur à lamelles fluorescent en rouge, jaune ou argenté. Combinez les couleurs à votre goût ! Avec ballast électronique et LEDs intégrés.

Alluminio anodizzato, metallo verniciato a polvere, materiale sintetico. Brick Base può essere impiegata come elemento singolo oppure ampliata con Brick Plus fino a tre elementi in totale. I singoli elementi ruotano di 360° e possono essere usati come uplight o downlight. Regolazione continua dell'intensità luminosa mediante interruttore a sensore con funzione memoria. Elementi disponibili in nero, blu o alluminio naturale. Schermo a lamelle in rosso fluorescente, giallo fluorescente o argento. Combinate i colori a piacere! Con alimentatore e LED integrati.

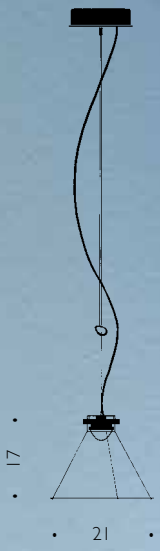



Figure not included.

### **Luminophor** *Till Armbrüster 2014*

Aluminium, Kunststoff. Das blaue Licht des LED-Moduls wird durch die beschichtete Scheibe in weißes Licht umgewandelt. ■ Aluminium, plastic. The round, coated slice converts the blue light emitted by the LED into white light. ■ Aluminium, plastique. Le disque enduit convertit la lumière bleue émise par le module LED en une lumière blanche. ■ Alluminio, materiale sintetico. La naturale luce blu emessa dal modulo LED, attraverso un disco stratificato viene trasformata in luce bianca.

 14 W LED, 1300 lm, Downlight 3000 K, CRI 90, Uplight 4500 K, CRI 90

 230/125/40V  200 cm



• 52 •

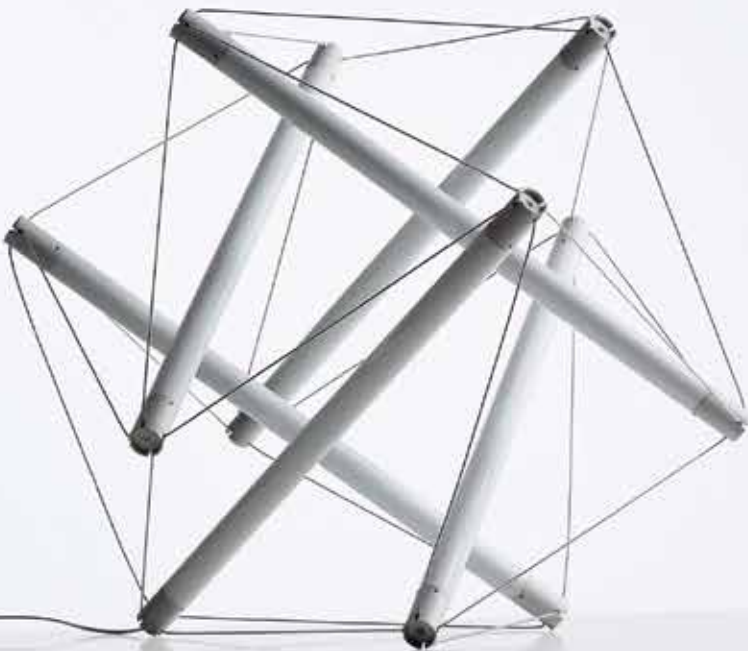
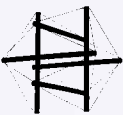



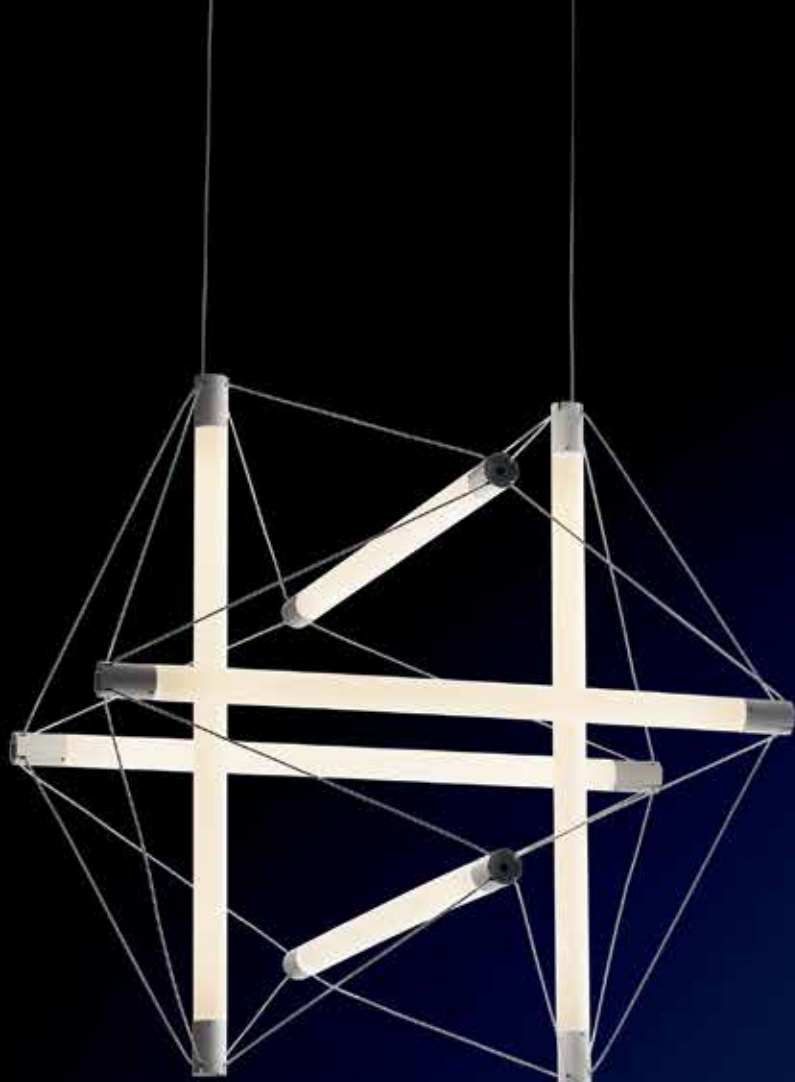



Light Structure 1970

The rebirth of  
the Orisquid:  
Light Structure.  
Designed by Peter  
Hamburger and  
Johannes Wauer.  
1970.

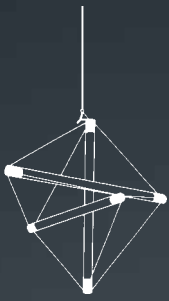

### Light Structure *Peter Hamburger, Ingo Maurer 1970/2013*

Plexiglas, Acryl, Aluminium. Sechs oder drei Röhren, von Kabeln in Spannung gehalten. Tischversion: Schnurtrafo mit Drehdimmer. Hängeversion: mit integriertem Transformator, dimmbar. Die LED-Röhren, Ø 2,5 cm, können nicht als Ersatzteil für die frühere Version der Light Structure (1970) verwendet werden. ■ Plexiglass, acrylic, aluminium. Six or three tubes, connected and held in tension by insulated wires. Table version: with continuously rotating transformer-dimmer. Hanging version: with integrated transformer, dimmable. The LED tubes, Ø 2.5 cm, can not be used as spare part for the former version of Light Structure (1970). ■ Plexiglas, acrylique, aluminium. Six ou trois tubes, connectés et tenues en tension aux câbles. Version pour table: avec transformateur à cordon avec variateur à rotation. Version pour suspension: avec tranformateur intégré, dimmable. Les tubes LED, Ø 2,5 cm, ne peuvent pas être usés comme pièce de rechange pour la version originale de Light Structure (1970). ■ Plexiglas, acrilico, alluminio. Sei o tre tubi collegati e tenuti in tensione da cavi isolati. Versione da tavolo: con trasformatore su cavo con dimmer a manopola rotante. Versione a sospensione: con trasformatore integrato, dimmerabile. I tubi LED, Ø 2,5 cm, non possono essere usati come pezzo di ricambio per la versione originale di Light Structure (1970).





**One New Flame** Moritz Waldemeyer, Ingo Maurer und Team 2013

Platine in Schwarz oder Rot, Metall, Kunststoff. Am oberen Ende einer schmalen Platine scheint eine Kerzenflamme zu flackern. Die Platine ist mit zwei feinen Kabeln aufgehängt. Das elektronische Netzteil ist in den schlichten, weiß lackierten Baldachin integriert. ■

Circuit board in black or red, metal, plastic. At the upper end of a sleek circuit board, suspended on fine wires, a candle flame seems to flicker. The electronic ballast is integrated in the simple white canopy. ■

Platine en noir ou rouge, métal, matière plastique. Une flamme de bougie semble s'embraser au bout d'une fine platine. La platine est suspendue par deux câbles fins. Le bloc d'alimentation électronique est intégré dans le simple baldaquin blanc lacqué. ■

Circuito stampato in nero o rosso, metallo, materiale sintetico. All'estremità superiore del sottile circuito stampato sembra muoversi la fiamma di una candela. Il circuito stampato è sospeso a due cavetti. L'alimentatore elettronico è integrato nel semplice rosone verniciato bianco. ■

All'estremità superiore del sottile circuito stampato sembra muoversi la fiamma di una candela. Il circuito stampato è sospeso a due cavetti. L'alimentatore elettronico è integrato nel semplice rosone verniciato bianco. ■

nel semplice rosone verniciato bianco.

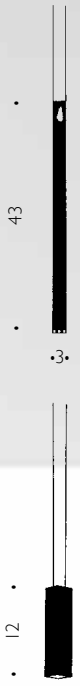

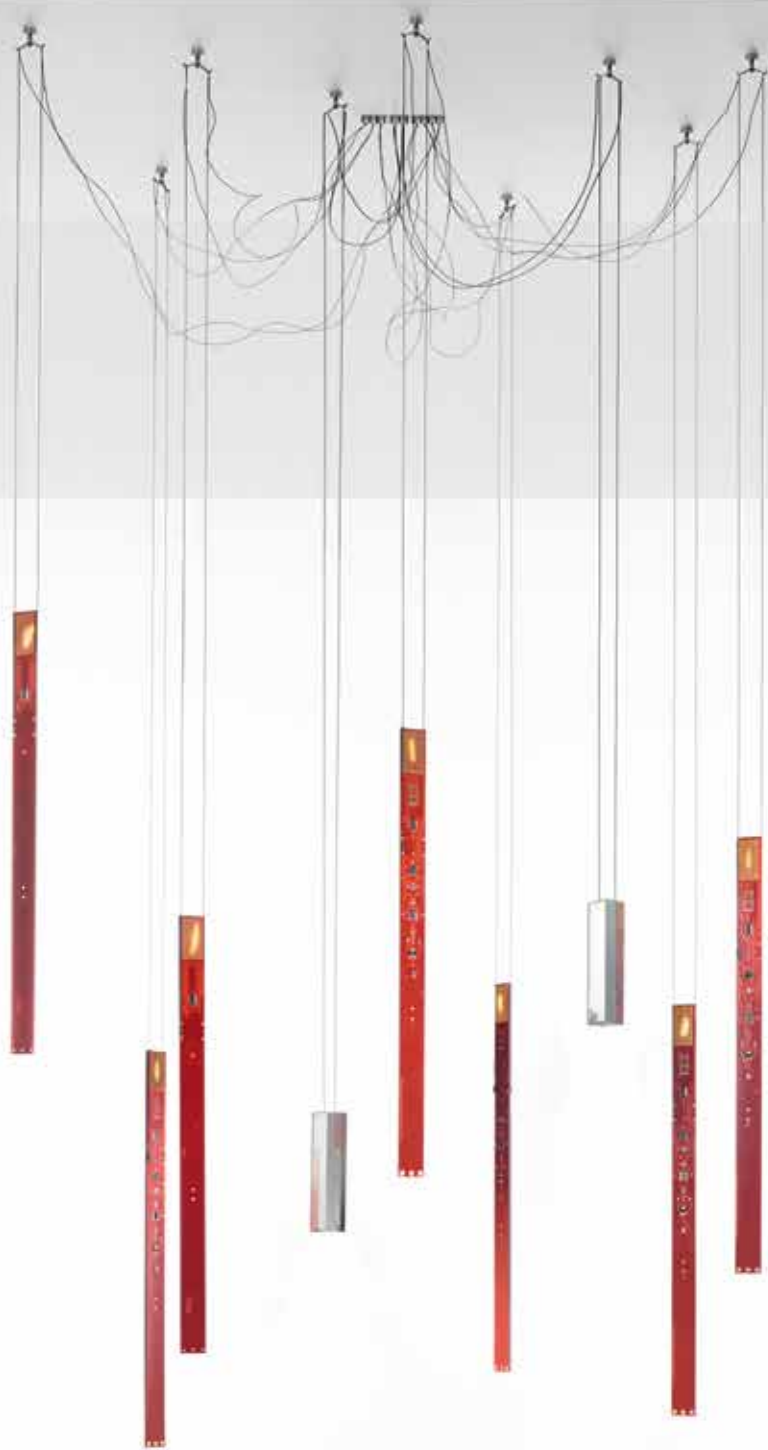

**Downlight  
also available  
in polished  
chrome finish.**



### **Flying Flames** *Moritz Waldemeyer, Ingo Maurer und Team, 2013*

Flying Flames ist ein neues flexibles System. Es ermöglicht die Gestaltung individueller Kerzenlüster und besteht aus Flame-Elementen, Downlight-Elementen und Baldachin. Die Elemente werden mit Magneten am Baldachin fixiert. Flame-Element: in Schwarz oder Rot, mit zwei LED-Displays, Dimmschalter auf der Platine. Downlight-Element: mit integriertem Touchdimmer mit Memory-Funktion. Anzahl und Farbe der Elemente wählbar. Baldachin aus weiß lackiertem Stahl, in zwei Größen, mit Steckverbindungen für bis zu zehn Flame-Elemente und maximal zwei Downlights. Elektronisches Netzteil im Baldachin. Material: Platine, Metall, Aluminium eloxiert, Kunststoff.

Flying Flames is a new flexible system, designed to permit individual versions of a chandelier. It consists of Flame Elements, Downlight Elements and canopy. The elements are placed freely with a magnet. Flame Element: in Black or Red, two LED displays, dimmer switch on the circuit board. Downlight Element: with touch dimmer with memory function. You decide on the number and colour of the Elements. Canopy, white lacquered steel, available in two sizes, with jacks for up to ten Flame Elements and a maximum of two Downlights. Electronic ballast integrated in the canopy. Material: Circuit board, metal, anodised aluminium, plastic.

Flying Flames est un nouveau système de lustre flexible, qui permet de concevoir facilement différents chandeliers personnalisés individuellement. Il combine les bougies LED à un élément downlight. Les deux éléments sont fixés librement par des aimants à la plaque du baldaquin. Élément Flame: en noir ou rouge, deux écrans LED programmés, avec bouton variateur de lumière. Élément Downlight: avec touch Dimmer intégré avec fonction mémoire. Le nombre et la couleur d'éléments Flame peuvent être choisis à votre convenance. Le baldaquin disponible en deux tailles différentes (acier; blanc lacqué) permet la connection jusqu'à dix éléments Flame et maximum deux Downlights. Bloc d'alimentation électronique intégré dans le baldaquin. Matériel: platine, métal, aluminium anodisé, matière plastique.

Flying Flames è un nuovo flessibile sistema di lampadario che consente di comporre molteplici lampadari a candela personalizzati. Consiste degli Elementi Flame, Elementi Downlight e rosone. Gli elementi vengono fissati al rosone mediante una calamita. Elemento Flame: in nero o rosso, con due schermi LED e pulsante per regolare l'intensità luminosa. Elemento Downlight: con un touch dimmer integrato con funzione memory. Quantità e colore degli Elementi Flame possono essere scelti a piacere. Rosone in acciaio verniciato bianco disponibile in due misure, con contatti per fino a dieci Elementi Flame e max. due Downlight. Alimentatore elettronico integrato nel rosone. Materiale: Circuito stampato, metallo, alluminio anodizzato, materiale sintetico.

Flame element:  2 x I28 LED, 5 V, 0,6 W, 2700 K, CRI 80  230/125/5 V, EEC A+  200 cm

Downlight:  7 W LED, 2700 K, 530 lm, CRI 90  230/125/38 V, EEC A+  200 cm



Il Cenacolo installation at Spazio Krizia, Milano, 2013





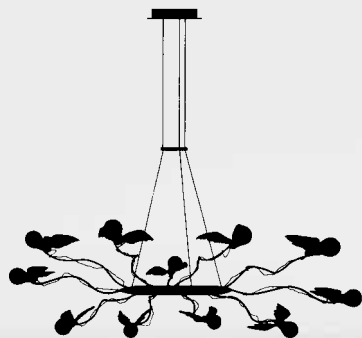

ca. 120

### **Birdie's Ring** Ingo Maurer 2013

Metall, Flügel aus Gänsefedern, 12 Niedervolt-Halogenbirnen. Drei in den runden Leuchtenkörper integrierte LEDs mit Reflektor. Glühbirnen und LEDs sind dimmbar. Birdie's Ring ist höhenverstellbar und kann auch mit einer leichten Neigung montiert werden. ■ Metal, goose-feather wings, 12 low-voltage halogen bulbs. Three LED's with reflectors, integrated into the round body. Bulbs and LED's are dimmable. Height adjustable. Also to be suspended at a slight angle. ■ Métal, ailes en plumes d'oie, ampoules halogène à bas voltage 12V, trois LEDs downlight avec réflecteurs intégrés dans le corps de la lampe. Les ampoules et LEDs peuvent être connectés et dimmés séparément. La Birdie's Ring est ajustable en hauteur et peut aussi être montée légèrement inclinée. ■ Metallo, ali in piume d'oca, 12 lampadine alogene a basso voltaggio, tre downlight a LED con riflettore integrati nell'anello. Le lampadine e i LED sono comandabili e regolabili separatamente. Birdie's Ring è regolabile in altezza e può anche essere installata leggermente inclinata.

 120 W, 1200 lm, 10 lm/W, 24 V  E 27  230/125/24 V

 3 LEDs, each 7 W, 530 lm, 2700 K





**Da + Dort** Christoph Matthias, Ingo Maurer 2003/2012

Papier, Edelstahl, Kunststoff. An drei Seilen aufgehängt. Innerhalb der Aufhängepunkte stufenlos höhenverstellbar und in alle Richtungen zu verschieben. Aufhängepunkte nach Wahl. Leuchtenkopf um 360° dreh- und 45° schwenkbar. Leuchtenkopf Ø 28 cm, Deckenbaldachin Ø 8 cm. ■ Paper, stainless steel, plastic. Suspended on three wires. Freely adjustable in height and width within the lamp's suspension points. Free choice of suspension points. Head of lamp rotates through 360° and tilts through 45°. Head of lamp Ø 28 cm, canopy Ø 8 cm. ■ Papier, acier affiné, matière plastique. Suspendue à trois fils. Hauteur réglable sans graduation entre les points de fixation. Se déplace dans toutes les directions. Points de fixation au choix. Tête de la lampe rotative à 360° et orientable à 45°. Tête de la lampe Ø 28 cm, baldaquin Ø 8 cm. ■ Carta, acciaio inossidabile, materiale sintetico. Sospesa a tre cavi. Regolazione continua dell'altezza entro i punti di fissaggio. Orientabile in tutte le direzioni. Punti di fissaggio a scelta. Il riflettore ruota di 360°, e si inclina di 45°. Riflettore Ø 28 cm, rosone Ø 8 cm.

💡 150 W Halogen, 2870 lm, 2900 K, 2000 h, EEC C ⚡ E 27, max. 150 W, A++-E 🖱️ 300 cm



max. 400

• ca. 50 •

• min. 80, max. 240 •

max. 260

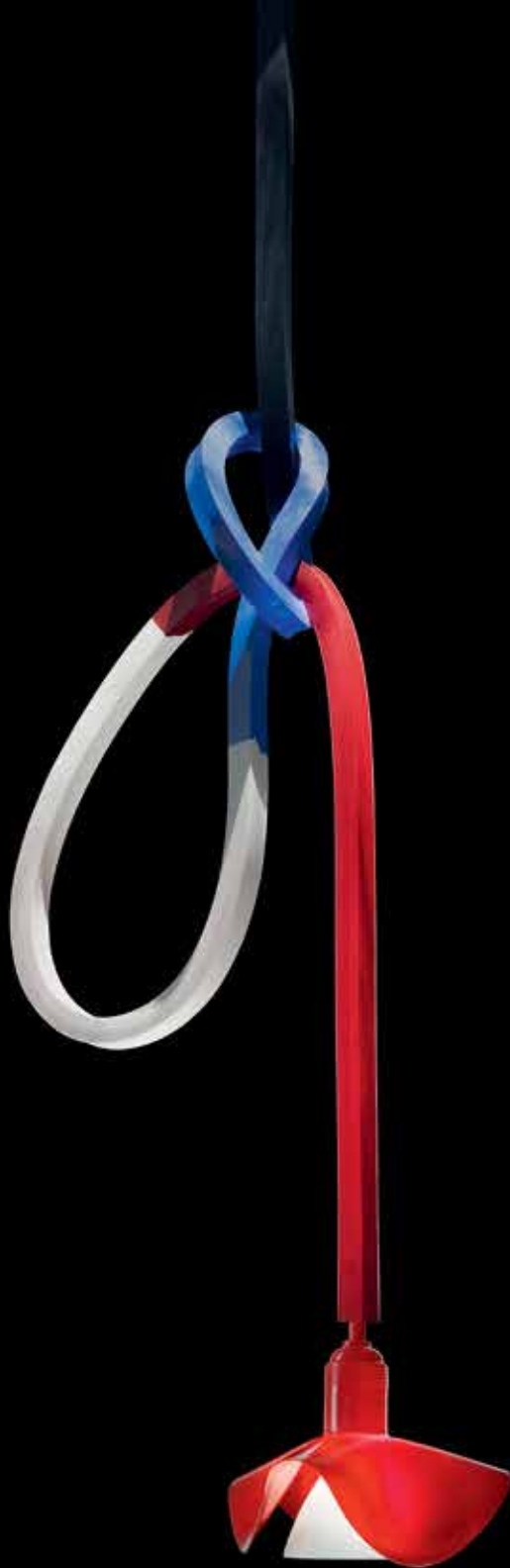

### **Zufall** Ingo Maurer und Team 2008

Sonderanfertigung aus farbigem, handgegossenem Silikon, Farben nach Absprache. Der Silikonkörper kann flexibel verknotet werden. Für Raumhöhen bis 300 cm. Baldachin Ø 8 cm. Lieferung mit Leuchtmittel. ■ Hand-made silicone body, bespoke colours. The silicone body is flexible. For ceiling heights up to 300 cm. Canopy Ø 8 cm. Complete with bulb. ■ Tuyau flexible en silicone spéciale faites main. De différentes couleurs pourront être réalisées sur demande. Pour hauteurs de pièce jusqu'à 300 cm. Baldachin Ø 8 cm. Livrée avec ampoule. ■ Corpo flessibile di silicone fatto a mano. Colori su richiesta. Per soffitti con altezze fino cm. 300. Rosone Ø cm. 8. Lampadina inclusa.



**Silly-Kon** Ingo Maurer und Team 2010

Silikon, Metall. Transparentes Kabel und Baldachin, Ø 8 cm. Lieferung mit Leuchtmittel.

■ Silicone, metal. Transparent cable and canopy, Ø 8 cm. Complete with bulb. ■

Silicone, métal. Câble et baldaquin transparents, Ø 8 cm. Livrée avec ampoule. ■ Silicone,

metallo. Cavo e rosone trasparenti, Ø cm. 8. Lampadina inclusa.

 70 W Halogen, 1200 lm, 2800K, 2000 h, EEC C  E27, max. 75 W, A++-E  200/450 cm

Recommended retrofit LED bulb for 230 volts available through Ingo Maurer.

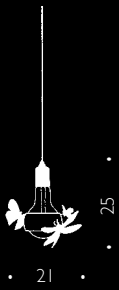

**Johnny B. Butterfly** *Ingo Maurer 2011*



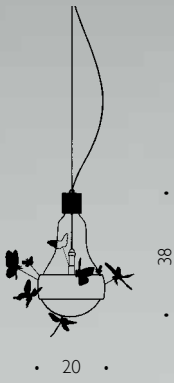

**J. B. Schmetterling** *Ingo Maurer 2011* Limited production

70 W Halogen, 1180 lm, 2800 K, 2000 h, EEC D B15d, max. 100 W, A++-E 250 cm

max. 125/400

21

28



**Lucetto** *Bernhard Dessecker, Ingo Maurer und Team 1995*

Glas, Kunststoff, hitzebeständiges Blendenmaterial. Stufenlos höhenverstellbar durch Umlenkrolle und Justierring. Baldachin Ø 13 cm, transparent. Für Raumhöhen bis 300 und 550 cm. Lieferung mit Leuchtmittel. ■ Glass, plastic, heat-resistant shade. Height freely adjustable with pulley and ring. Canopy, Ø 13 cm, transparent. For ceiling heights up to 300 and 550 cm. Complete with bulb. ■ Verre, matière plastique, écrans résistant à la chaleur. Régable en hauteur sans graduation par poulie de renvoi et anneau coulissant. Baldaquin Ø 13 cm, transparent. Pour hauteurs de pièce jusqu'à 300 et 550 cm. Livrée avec ampoule. ■ Vetro, materiale sintetico, schermo termoresistente. Regolazione continua dell'altezza con carrucola e anello di bloccaggio. Rosone Ø cm. 13, trasparente. Per soffitti con altezze fino cm. 300 e 550. Lampadina inclusa.

 52 W PAR 30 Flood 38° Halogen, 550 lm, 2800 K, 1500 h, EEC C

 E27 glass (125 V) G9, max. 75 W, A++-E



**Johnny B. Good** Ingo Maurer, Bernhard Dessecker 2002

Glas, Kunststoff. Höhenverstellbar. Weißer Blendenring, Baldachin Ø 14 cm. V1: Stufenlos dimmbar durch Sensorschalter mit Memo-Funktion, für Raumhöhen bis 300 cm.

V2: ohne Sensorschalter, d. h. ohne das rote Kabel. Für Raumhöhen bis 550 cm. Lieferung mit Leuchtmittel. ■ Glass, plastic. Height adjustable. White shade ring. Canopy Ø 14 cm.

V1: Continuously variable dimmer with sensor switch and memo function, for ceiling heights up to 300 cm. V2: no sensor switch, that is without the red cable. For ceiling heights up to 550 cm. Complete with bulb. ■ Verre, matière plastique. Réglable en hauteur. Abat-jour blanc. Baldaquin Ø 14 cm. V1: réglage d'intensité lumineuse continu par interrupteur sensor avec fonction mémo, pour des hauteurs de plafond jusqu'à 300 cm.

V2: sans interrupteur, c'est-à-dire sans le câble rouge. Pour des hauteurs de plafond jusqu'à 550 cm. Livrée avec ampoule. ■ Vetro, materiale sintetico. Regolabile in altezza. Schermo bianco. Rosone Ø 14 cm. V1: Regolazione continua della luminosità mediante un interruttore a sensore con funzione di memoria, per soffitti con altezza fino a 300 cm.

V2: senza interruttore a sensore, senza il cavo rosso. Per soffitti con altezza fino a 550 cm; varialuce raccomandato. Lampadina inclusa.

V2: senza interruttore a sensore, senza il cavo rosso. Per soffitti con altezza fino a 550 cm; varialuce raccomandato. Lampadina inclusa.

V2: senza interruttore a sensore, senza il cavo rosso. Per soffitti con altezza fino a 550 cm; varialuce raccomandato. Lampadina inclusa.



**Alizz C. Cooper** Ingo Maurer und Team 2008

Metall, Kunststoff, Gummischlauch. Der flexible Arm ermöglicht die variable Einstellung des Reflektors. Reflektor 360° um das Leuchtmittel drehbar. Eine Kunststoffschnur sichert die Position des Reflektors. Baldachin Ø 8,5 cm. Lieferung mit Leuchtmittel. ■ Metal, plastic, rubber hose. The flexible arm allows variable adjustment of the reflector. Reflector rotates through 360° around the bulb. A fine plastic string secures the position of the extended armature. Canopy Ø 8,5 cm. Complete with bulb. ■ Métal, matière plastique, tuyau en caoutchouc. Le bras flexible permet le réglage variable du réflecteur. Réflecteur rotatif de 360° autour de l'ampoule. Un fil en matière plastique fixe la position du réflecteur. Baldaquin Ø 8,5 cm. Livrée avec ampoule. ■ Metallo, materiale sintetico, tubo di gomma. Il braccio flessibile permette la regolazione variabile del riflettore. Riflettore rotante di 360° intorno alla lampadina. Un filo in materiale sintetico assicura la posizione del riflettore. Rosone Ø cm. 8,5. Lampadina inclusa.

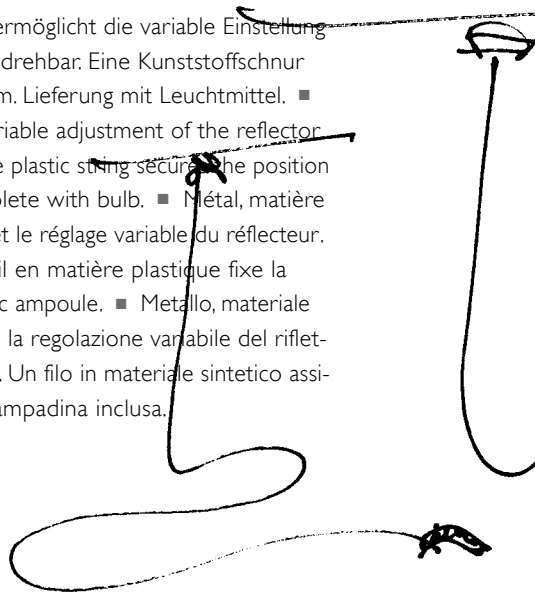

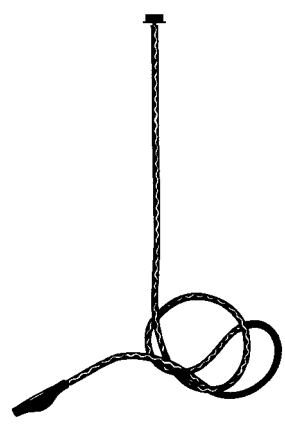
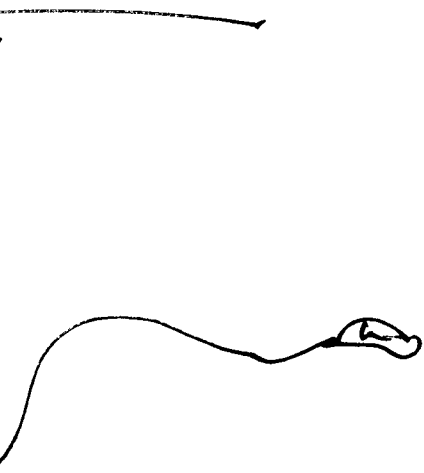
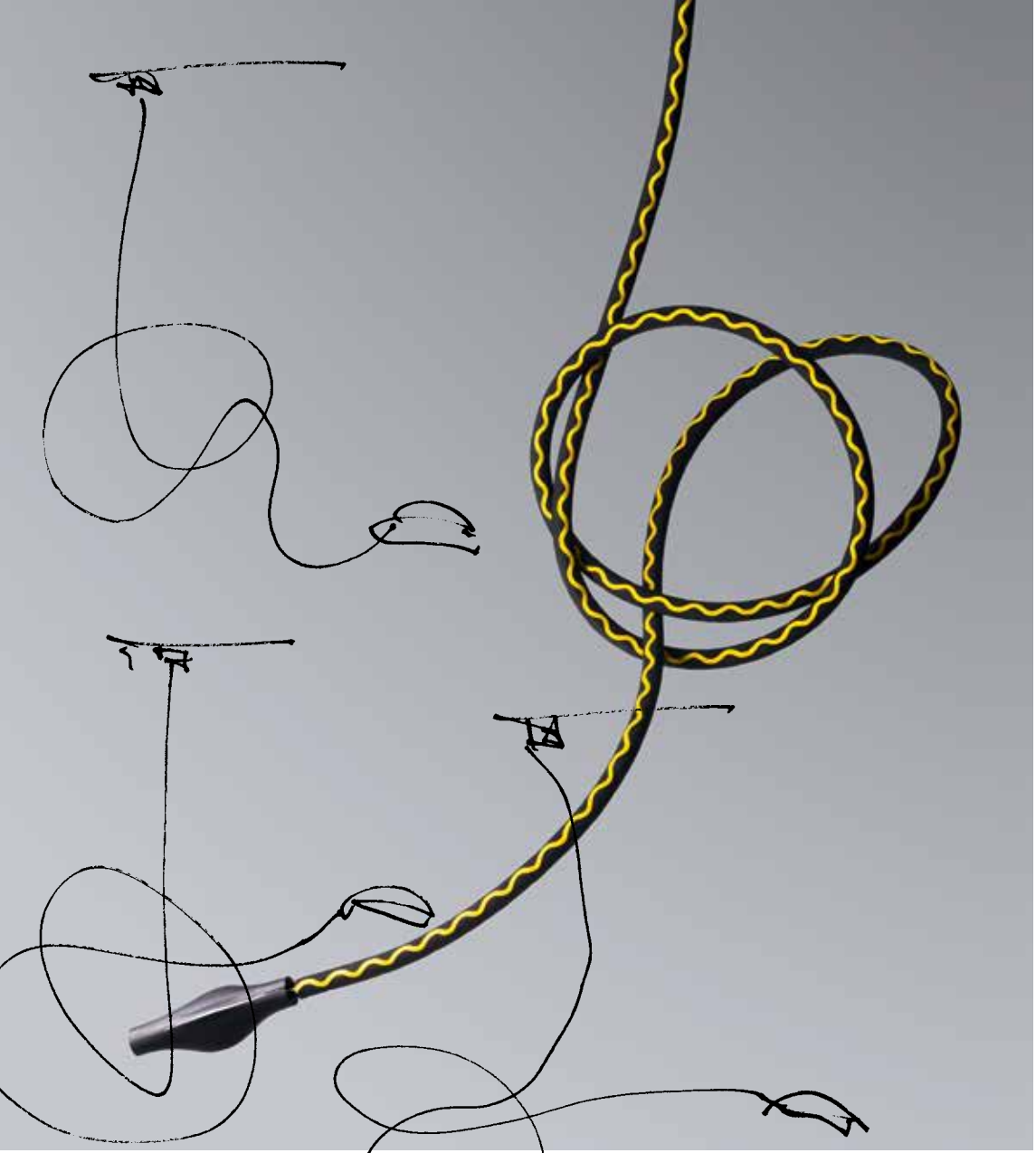

max. 320



**Metall C. Cooper** Ingo Maurer und Team 2009

Metall, Kunststoff. Der flexible Arm ermöglicht die variable Einstellung des Reflektors. Reflektor 360° um das Leuchtmittel drehbar. Eine Kunststoffschnur sichert die Position des Reflektors. Baldachin Ø 8,5 cm. Lieferung mit Leuchtmittel. ■ Metal, plastic. The flexible arm allows variable adjustment of the reflector. Reflector rotates through 360° around the bulb. A fine plastic string secures the position of the extended armature. Canopy Ø 8,5 cm. Complete with bulb. ■ Métal, matière plastique. Le bras flexible permet le réglage variable du réflecteur. Réflecteur rotatif de 360° autour de l'ampoule. Un fil en matière plastique fixe la position du réflecteur. Baldaquin Ø 8,5 cm. Livrée avec ampoule. ■ Metallo, materiale sintetico. Il braccio flessibile permette la regolazione variabile del riflettore. Riflettore rotante di 360° intorno alla lampadina. Un filo in materiale sintetico assicura la posizione del riflettore. Rosone Ø cm. 8,5. Lampadina inclusa.

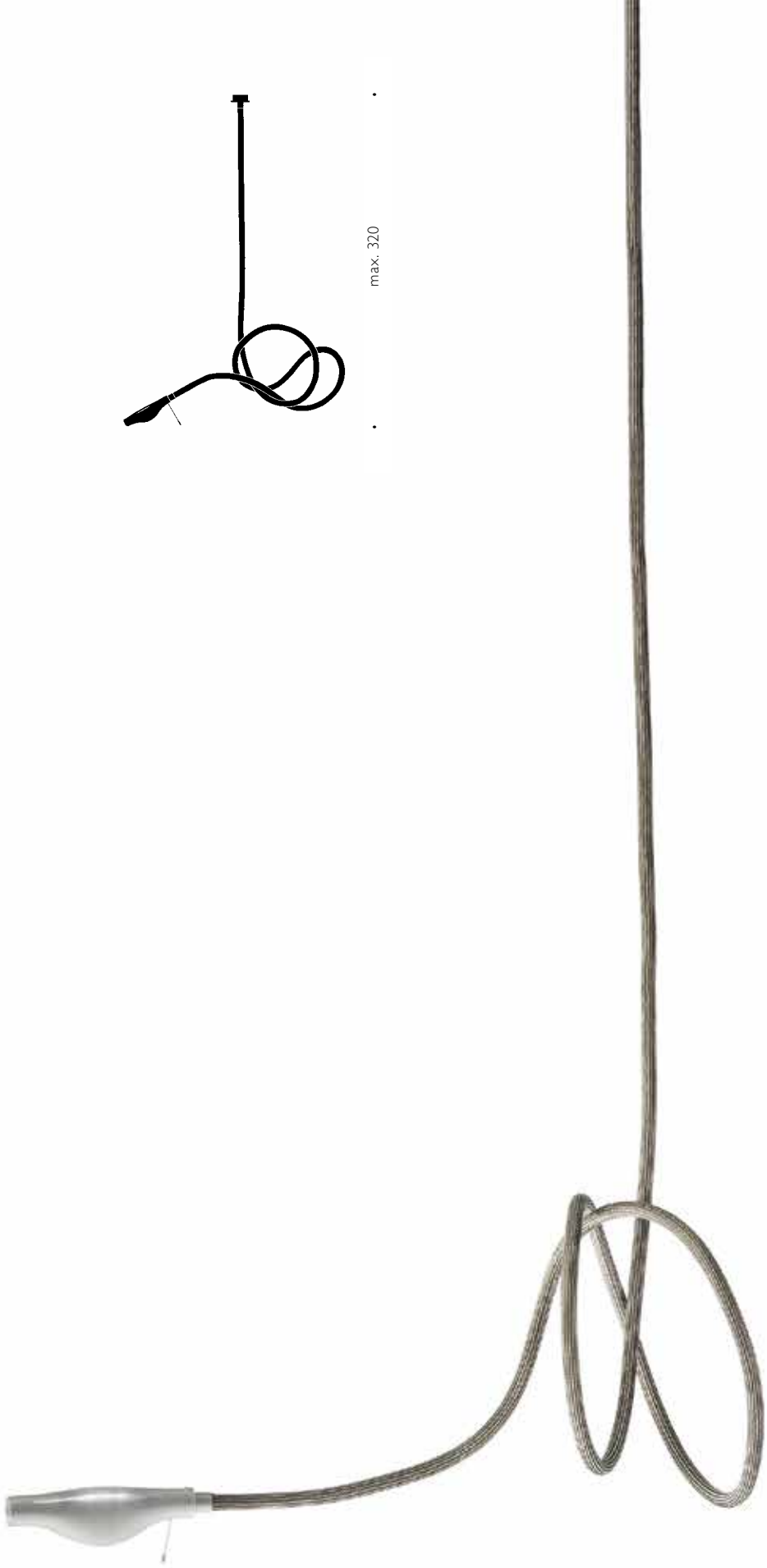



**Wo bist du, Edison, ...? Ingo Maurer 1997**

Acrylglas, Aluminium, Hologramm 360°. Transformator im Baldachin, Ø 13 cm, integriert. Lieferung mit Leuchtmittel. Kann nicht direkt auf den Deckenauslass montiert werden.

■ Acrylic glass, aluminium, hologram 360°. Transformer integrated in canopy, Ø 13 cm. Complete with bulb. It is not possible to mount the lamp directly on the ceiling outlet. ■ Verre acrylique, aluminium, hologramme 360°. Transformateur intégré dans le baldaquin, Ø 13 cm. Livrée avec ampoule. Ne peut être montée directement sur la sortie électrique du plafond. ■ Vetro acrilico, alluminio, ologramma 360°. Trasformatore integrato nel rosone, Ø 13 cm. Lampadina inclusa. Non può essere collegata direttamente all'uscita della corrente a soffitto.

Direkte Sonneneinstrahlung und Nikotin können die Lebensdauer der Hologramme reduzieren. ■ Direct sunlight and nicotine may reduce the life span of the holograms.

■ Une exposition directe au soleil et à la nicotine peut réduire la durée de vie des hologrammes. ■ L'esposizione diretta al sole e alla nicotina possono ridurre la durata degli ologrammi.



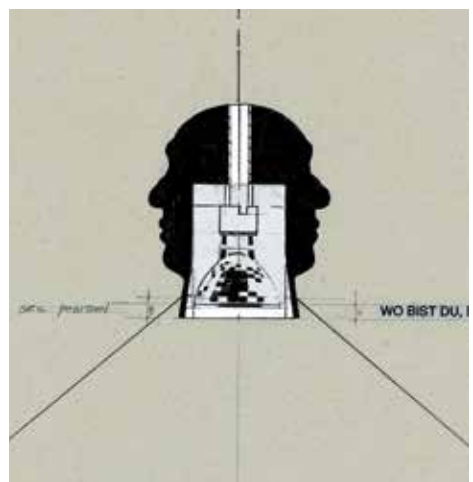
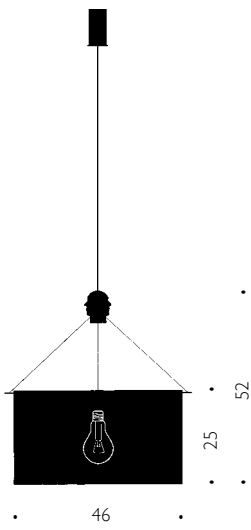

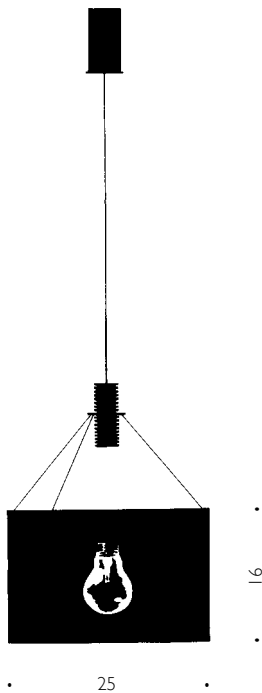

### **Eddie's Son** *Ingo Maurer und Eckhard Knuth 2005*

Kunststoff, Metall, Hologramm 360°. Transformator im Baldachin integriert. Lieferung mit Leuchtmittel. ■ Plastic, metal, hologram 360°. Transformer integrated in canopy. Complete with bulb. ■ Matière plastique, métal, hologramme 360°. Transformateur intégré dans le baldaquin. Livrée avec ampoule. ■ Materiale sintetico, metallo, ologramma 360°. Trasformatore integrato nel rosone. Lampadina inclusa.

Direkte Sonneneinstrahlung und Nikotin können die Lebensdauer der Hologramme reduzieren. ■ Direct sunlight and nicotine may reduce the life span of the holograms. ■ Une exposition directe au soleil et à la nicotine peut réduire la durée de vie des hologrammes. ■ L'esposizione diretta al sole e alla nicotina possono ridurre la durata degli ologrammi.

 Halogen 
  GY 6,35, max. 50 W 
  230/125/12 V 
  300 cm

No EEC – for details see our website [www.ingo-maurer.com](http://www.ingo-maurer.com)





## Inspired by Man Ray



OH MAN, IT'S A RAY! uses incandescent low voltage 24 V, 15 W bulbs.  
Design by Ingo Maurer und Team. Ingo Maurer was inspired by the work  
of the artist Man Ray. This lamp is available in various sizes and made with  
the express permission of the Man Ray Trust

© 2010 Man Ray Trust, Paris | VG Bild-Kunst

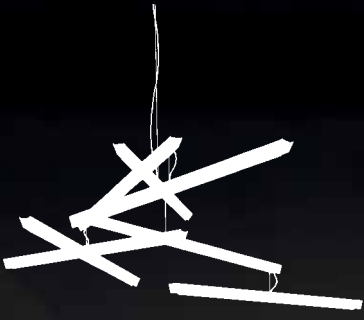

ca. 250

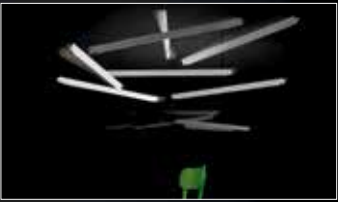

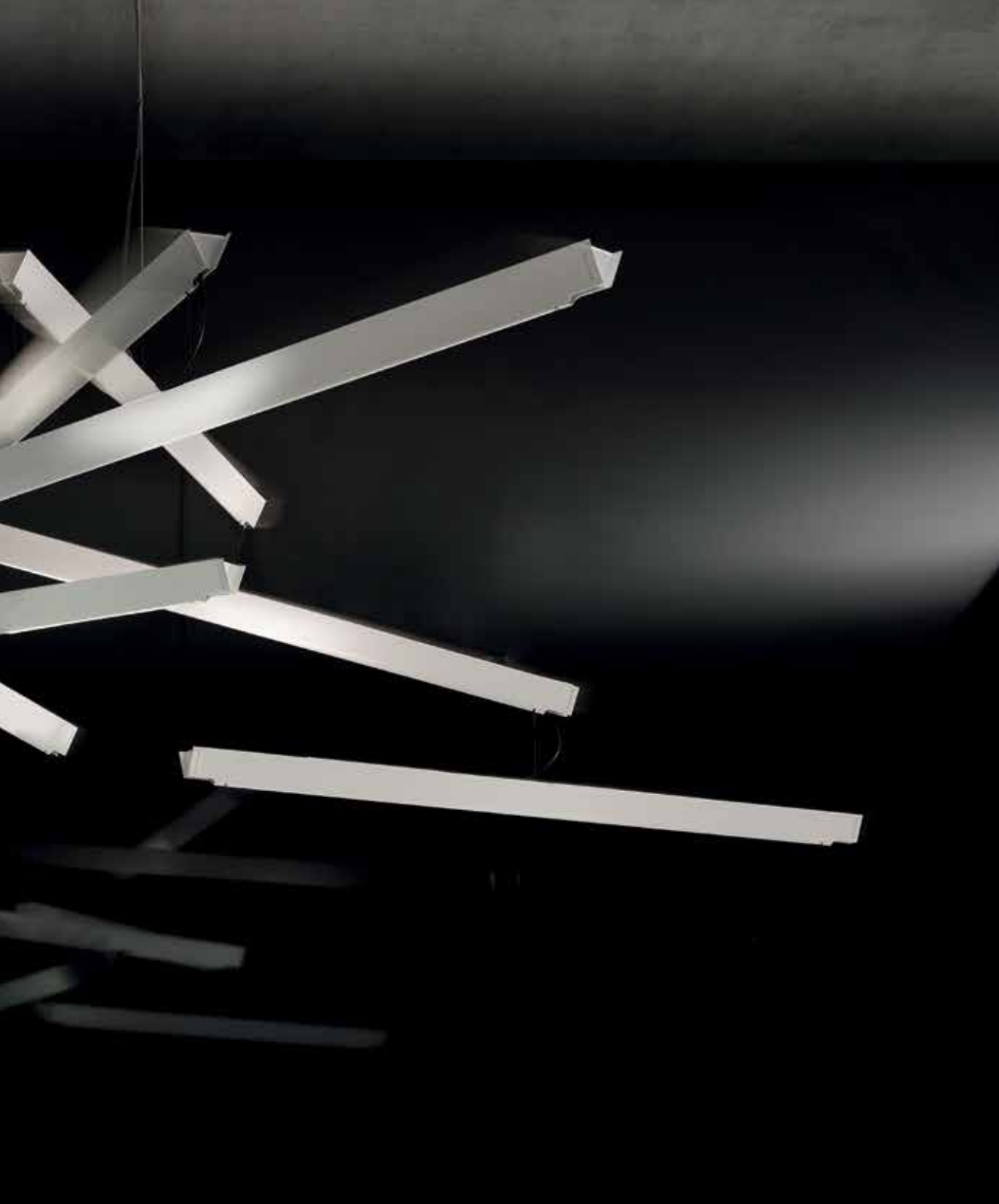

Derived from OH MAN IT'S A RAY!

ManOMan is a free, playful mobile, an up-lighting lamp that every other moment is a one of a kind. A new addition in our collection that will be available soon(er) or later.

**ManOMan** Ingo Maurer und Team 2011

 14 x 48 W (125 V: 14 x 60 W) Halogen, 740/10360 lm, 2800 K, 2000 h, EEC D  
 G9, max. 60 W, A++-E  200 cm



### **Lacrime del Pescatore** Ingo Maurer 2009

Drei Nylonnetze in verschiedenen Größen, ca. 350 Kristalle. Das Leuchtmittel Ø 11 cm und der Transformator werden separat an der Wand befestigt. Nicht dimmbar. Lieferung mit Leuchtmittel. ■ Layered nylon nets in three different sizes with approximately 350 crystals. The light source Ø 11 cm and the transformer are fixed separately to the wall. Not dimmable. Complete with bulb. ■ 3 filets en nylon de tailles différentes, environ 350 cristaux. Le spot Ø 11 cm e le transformateur à accrocher séparément au mur. Non dimmable. Livrée avec ampoule. ■ 3 reti in nylon di misure differenti, 350 cristalli ca. La lampadina Ø cm. 11 e il trasformatore vengono fissata al muro separatamente. Non dimmerabile. Lampadina inclusa.

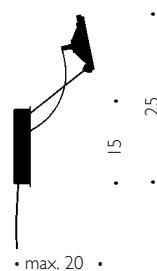





One lamp, endless possibilities. You decide.

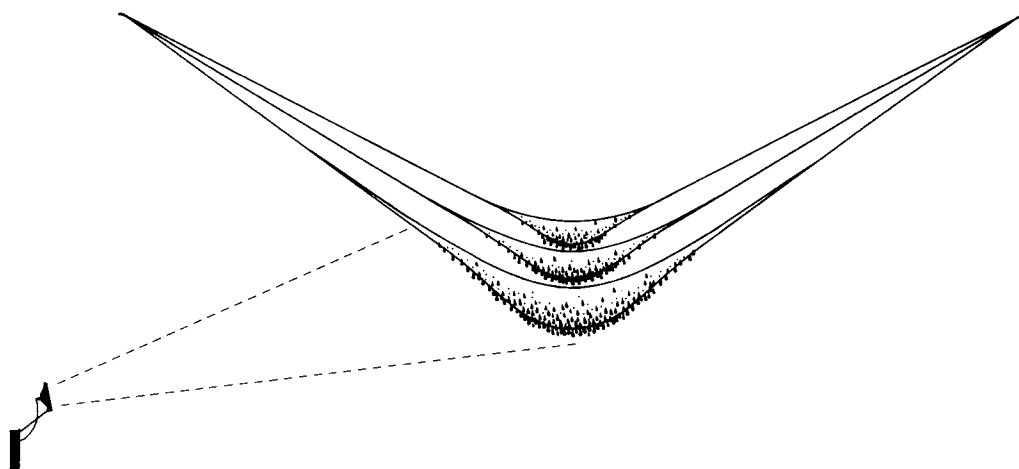

Use Me C., an optional downlight for Lacrime del Pescatore is available. See page 280.



### **Birds Birds Birds** Ingo Maurer 1992

Kronleuchter mit 24 Niedervolt-Glühlampen und Flügeln aus Gänsefedern. Im Baldachin (Ø 30 cm) integrierter Transformator, verzinnte Metallteile. Kabel in Transparent oder Rot/Blau. Sonderlängen auf Anfrage. Die einzelnen Glühlampen sind individuell beweglich. Lieferung mit Leuchtmitteln und sechs Ersatzglühlampen. ■ Chandelier with 24 low-voltage bulbs and goose-feather wings. Canopy (Ø 30 cm) with built-in transformer, tin-plated metal parts. Cables in transparent or red/blue. Alternative lengths available on request. Bulbs individually adjustable. Supplied with full set of bulbs, plus 6 spares. ■ Lustre avec 24 ampoules à bas voltage et des ailes en plumes d'oie. Transformateur intégré dans le baldaquin (Ø 30 cm), parties métalliques étamées. Câbles transparents ou rouges/bleus. Longueurs spéciales sur demande. Chaque ampoule est mobile individuellement. Livrée avec ampoules, plus 6 ampoules de rechange. ■ Lampadario con 24 lampadine a basso voltaggio e ali in piume d'oca. Trasformatore integrato nel rosone (Ø 30 cm), parti zincate in metallo. Cavi trasparenti o rossi/blu. Lunghezze speciali su richiesta. Le lampadine sono orientabili individualmente. Fornito con lampadine e 6 lampadine di ricambio.

**24 V Halogen EU approved**



**Birdie** Ingo Maurer 2002

Kronleuchter mit 12 Niedervolt-Glühlampen und Flügeln aus Gänsefedern. Im Baldachin integrierter Transformator, verzinnnte Metallteile. Kabel in Rot oder Transparent. Für Raumhöhen von 230 bis 260 cm. Abhängenzubehör für größere Raumhöhen separat erhältlich. Lieferung mit Leuchtmitteln und zwei Ersatzglühlampen. ■ Chandelier with 12 low-voltage bulbs and goose-feather wings. Canopy with built-in transformer, tin-plated metal parts. Cables in red or transparent. For ceiling heights of 230 to 260 cm. Suspension kit for higher ceilings available on request. Supplied with full set of bulbs plus two spares. ■ Lustre avec 12 ampoules à bas voltage et des ailes en plumes d'oie. Transformateur intégré dans le baldaquin, parties métalliques étamées. Câbles transparents ou rouges. Pour hauteurs de plafond de 230 à 260 cm. Accessoire de suspension disponible sur demande pour des pièces plus hautes. Livrée avec ampoules, plus deux ampoules de rechange. ■ Lampadario con 12 lampadine a basso voltaggio e ali in piume d'oca. Trasformatore integrato nel rosone, parti in metallo stagnate. Cavi rossi o trasparenti. Per soffitti con altezza da cm. 230 a cm. 260. Kit sospensione per soffitti più alti disponibile su richiesta. Fornito con lampadine e due lampadine di ricambio.

24V Halogen EU approved

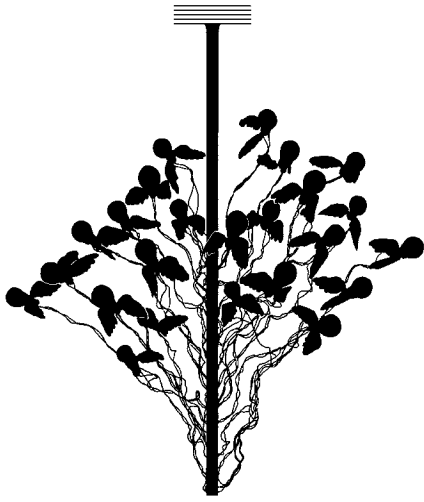

ca. 120

min. 130, max. 350

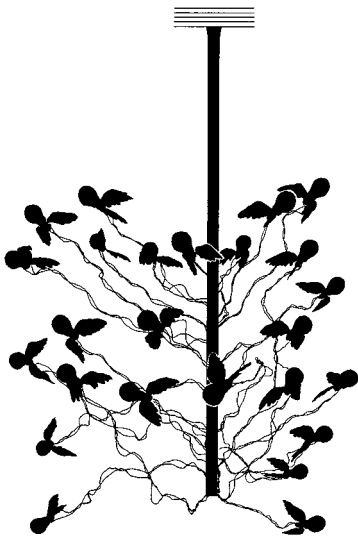

**Birds, Birds, Birds**

max. 240 W Halogen E27 transformer 24 V

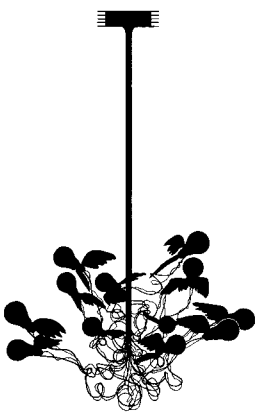

ca. 70

100

**Birdie**

max. 120 W Halogen E27 transformer 24 V

Made to be co-designed by you.

Enjoy the ability to style it anyway you wish.





**Pierre ou Paul** *Ingo Maurer und Team 1996*

Aluminium, Edelstahl. Innenfläche in Gold, Platin oder farbig matt lackiert. Höhenverstellbar durch drei Gegengewichte. Sonderlängen auf Anfrage. Baldachin mit Abdeckscheibe Ø 16 cm. Version 1: ca. 32 kg. Version 2: Ø ca. 22 kg. Lieferung mit Leuchtmittel. ■ Aluminium, stainless steel. Inner surface gold, platinum or mat colour finish. Height adjustable by means of three counter-weights. Alternative lengths available on request. Canopy with base-plate cover Ø 16 cm. Version 1: approx. 32 kg. Version 2: approx. 22 kg. Complete with bulb. ■ Aluminium, acier inoxydable. Surface intérieure dorée à la main, platine ou vernis en couleur mat. Réglable en hauteur au moyen de trois contre-poids. Longueurs spéciales sur demande. Baldaquin avec rondelle de recouvrement 16 cm. Version 1: env. 32 kg. Version 2: env. 22 kg. Livrée avec ampoule. ■ Alluminio, acciaio inossidabile, superficie interna in oro, platino vernice colorata opaca. Altezza regolabile mediante tre contrappesi. Lunghezze speciali su richiesta. Rosone con piastra di copertura Ø 16 cm. Versione 1: ca. 32 kg. Versione 2: ca. 22 kg. Lampadina inclusa.



### **XXL Dome** Ingo Maurer 1999

Fiberglas, außen alusilber, innen leucht-pink, -orange, -rot oder -grün matt lackiert. Sonderfarben möglich. Sonderlängen auf Anfrage. Gewicht ca. 45 kg. Lieferung mit Leuchtmittel. ■ Fibreglass, exterior aluminium-silver, interior fluorescent pink, orange, red or green mat lacquer. Other colours on request. Alternative lengths available on request. Weight approx. 45 kg. Bulb included. ■ Fibre de verre, extérieur vernis couleur argent, intérieur vernis mat, rose pink, orange, rouge ou vert fluorescent. Couleurs spéciales possibles. Longueurs spéciales sur demande. Poids env. 45 kg. Livrée avec ampoule. ■ Vetroresina, superficie esterna verniciata color argento, superficie interna luminescente pink, arancione, rosso o verde, vernice opaca. Colori speciali su richiesta. Lunghezze speciali su richiesta. Peso ca. 45 kg. Lampadina inclusa.

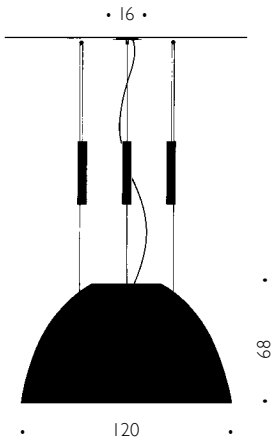

**Pierre ou Paul**

Version 1 max. 250 W E27 cable 400 cm

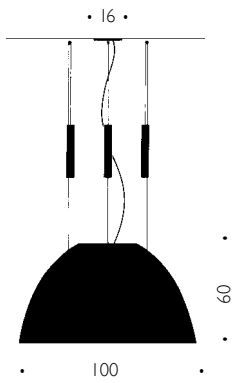

**Pierre ou Paul**

Version 2 max. 250 W E27 cable 400 cm

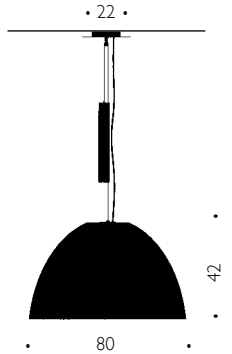

**Pierre ou Paul S**

max. 250 W E27 cable 400 cm  
With one counterweight only

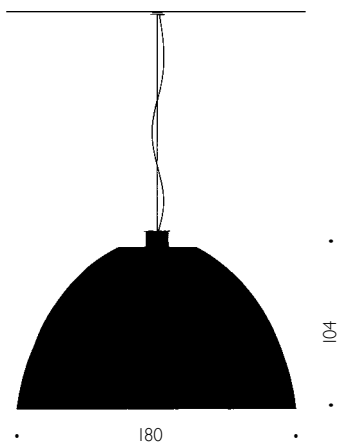

**XXL Dome**

max. 250 W E27  
CDM Version: max. 150 W HID G12 cable: 400 cm





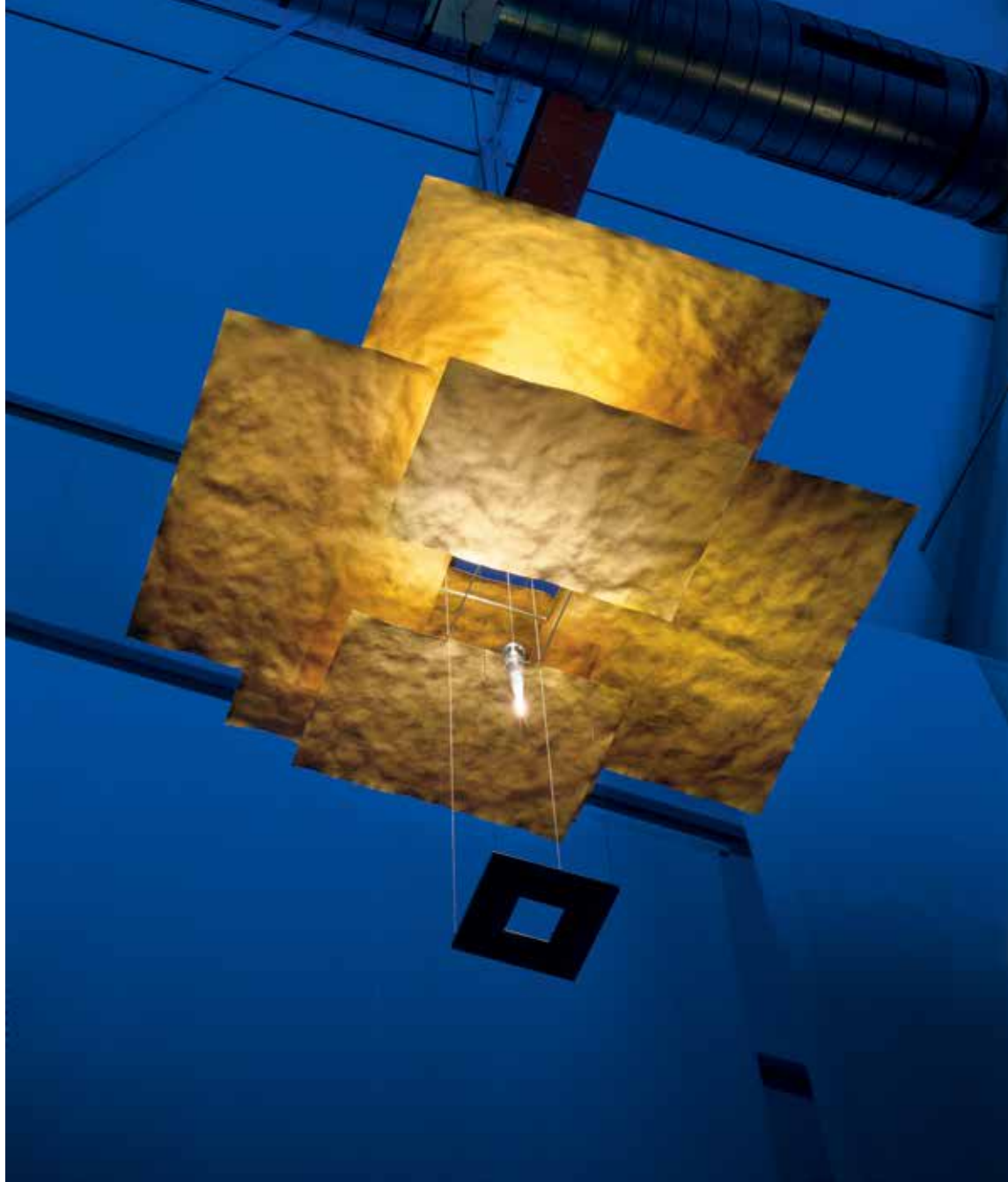

**Oh Mei Ma** *Ingo Maurer 1993*

Sechs Blätter aus blattvergoldetem Papier. Senklot aus Plexiglas. Sonderlängen auf Anfrage. Lieferung mit Leuchtmittel. ■ Six sheets of gold-plated paper. Plumb made of plexiglass. Alternative lengths available on request. Complete with bulb. ■ Six feuilles en papier doré à la feuille. Fil à plomb en plexiglas. Longueurs spéciales sur demande. Livrée avec ampoule. ■ Sei fogli di carta dorata. Pendolo in plexiglas. Lunghezze speciali su richiesta. Lampadina inclusa.



**Oh Mei Ma Weiss** Ingo Maurer und Team 1997/2007

Metall, Glas. Sechs Blätter aus Aluminium, matt weiß lackiert. Sonderlängen auf Anfrage. Lieferung mit Leuchtmitteln. ■ Metal, glass. Six sheets of aluminium, mat white finish. Alternative lengths available on request. Complete with bulbs. ■ Métal, verre. Six feuilles en tôle d'aluminium, vernis en blanc mat. Longueurs spéciales sur demande. Livrée avec ampoules. ■ Metallo, vetro. Sei fogli in lamiera d'alluminio, verniciatura bianca opaca. Lunghezze speciali su richiesta. Lampadina inclusa.



**Oh Mei Ma Kabir** *Ingo Maurer und Team 1997/2007*

Sechs Blätter aus blattvergoldetem Papier. Senklot aus Plexiglas. Auch mit versilbertem Papier und Senklot aus Metall lieferbar. Sonderlängen auf Anfrage. Lieferung mit Leuchtmitteln. ■ Six sheets of gold-plated paper. Plumb made of plexiglass. Silver-coated version also available, with plumb in steel. Alternative lengths available on request. Complete with bulbs. ■ Six feuilles en papier papier doré à la feuille. Fil à plomb en plexiglas. Egalement disponible en papier argenté avec fil à plomb en acier. Longeurs spéciales sur demande. Livrée avec ampoules. ■ Sei fogli di carta dorata. Pendolo in plexiglas. È disponibile anche la versione in carta argentata con pendolo in acciaio. Lunghezze speciali su richiesta. Lampadine incluse.

**Oh Mei Ma Kabir Weiss** *Ingo Maurer und Team 1997/2007*

Metall, Glas. Sechs Blätter aus Aluminium, matt weiß lackiert. Sonderlängen auf Anfrage. Lieferung mit Leuchtmitteln. ■ Metal, glass. Six sheets of aluminium, mat white finish. Alternative lengths available on request. Complete with bulbs. ■ Métal, verre. Six feuilles en tôle d'aluminium, vernis en couleur blanc mat. Longeurs spéciales sur demande. Livrée avec ampoules. ■ Metallo, vetro. Sei fogli in lamiera d'alluminio, verniciatura bianca opaca. Lunghezze speciali su richiesta. Lampadine incluse.

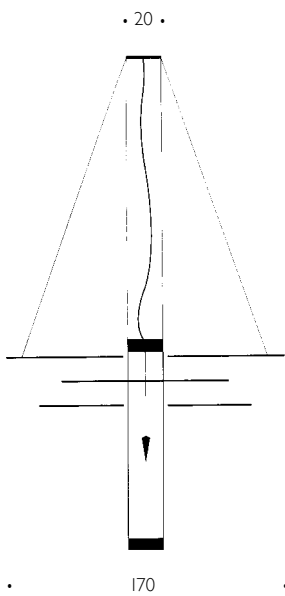

Oh Mei Ma Kabir

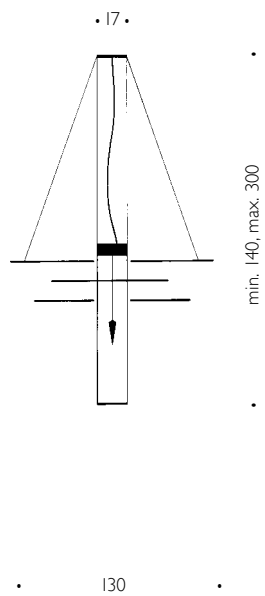

Oh Mei Ma







### Zettel'z Viva l'Italia\* Ingo Maurer 2010

Japanpapier, Edelstahl, hitzebeständiges satiniertes Glas. Baldachin Ø 11 cm. 80 bedruckte Blätter DIN A5. Lieferung mit Leuchtmitteln. ■ Japanese paper, stainless steel, heat-resistant satin-frosted glass. Canopy diameter Ø 11 cm. 80 printed paper sheets DIN A5. Complete with bulbs. ■ Acier inoxydable, verre satiné résistant à la chaleur, papier japonais. Baldaquin Ø 11 cm. 80 feuilles DIN A5 imprimées. Livrée avec ampoules. ■ Acciaio inossidabile, vetro satinato termoresistente, carta giapponese. Rosone Ø cm. 11. 80 fogli prestampati DIN A5.

\* Limited Edition

💡 205 W Halogen, 4200 lm, 3000 K, 2000 h/52 W PAR 30 Flood 38°, 550 lm, 2800 K, 1500 h, EEC C

🌀 2 x E27 (125 V: 1 x E27, 1 x G9), max. 250/75 W, A++-E 🌀 330 cm





For the anniversary of 150 years of the Italian Republic.

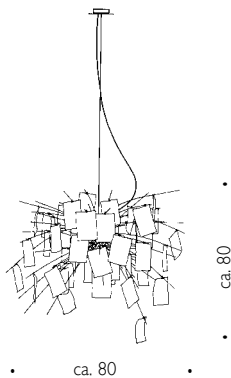

Zettel'z 6

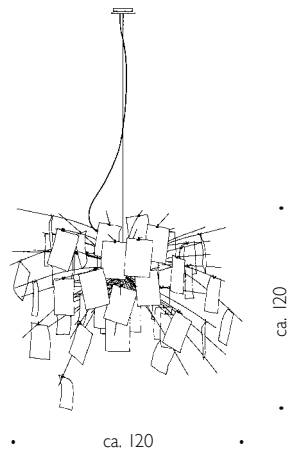

Zettel'z Viva l'Italia  
Zettel'z 5

### Zettel'z 6 Ingo Maurer 1998

Japanpapier, Edelstahl, hitzebeständiges satiniertes Glas. Baldachin Ø 11 cm. 40 bedruckte und 40 unbedruckte Blätter DIN A6. Lieferung mit Leuchtmittel. Ein Set mit 80 unbedruckten Blättern kann nachbestellt werden. ■ Japanese paper, stainless steel, heat-resistant satin-frosted glass. Canopy Ø 11 cm. 40 printed and 40 blank paper sheets DIN A6. Complete with bulb. Replacement set of 80 blank paper sheets available. ■ Acier inoxydable, verre satiné résistant à la chaleur, papier japonais. Baldaquin Ø 11 cm. 40 feuilles imprimées et 40 feuilles blanches DIN A6. Livrée avec ampoule. 80 feuilles blanches de rechange disponibles. ■ Carta giapponese, acciaio inossidabile, vetro satinato termoresistente. Rosone Ø cm. 11. 40 fogli prestampati e 40 fogli bianchi DIN A6. Lampadina inclusa.

💡 205 W Halogen, 4200 lm, 3000 K, 2000 h, EEC C 🌀 E27, max. 250, A++-E 📏 200/400 cm

### Zettel'z 5 Ingo Maurer 1997

Japanpapier, Edelstahl, hitzebeständiges satiniertes Glas. Baldachin Ø 11 cm. 31 bedruckte und 49 unbedruckte Blätter DIN A5. Lieferung mit Leuchtmitteln. Ein Set mit 80 unbedruckten Blättern kann nachbestellt werden. ■ Japanese paper, stainless steel, heat-resistant satin-frosted glass. Canopy Ø 11 cm. 31 printed and 49 blank paper sheets DIN A5. Complete with bulbs. Replacement set of 80 blank paper sheets available. ■ Acier inoxydable, verre satiné résistant à la chaleur, papier japonais. Baldaquin Ø 11 cm. 31 feuilles imprimées et 49 feuilles blanches DIN A5. Livrée avec ampoules. 80 feuilles blanches de rechange disponible. ■ Carta giapponese, acciaio inossidabile, vetro satinato termoresistente. Rosone Ø cm. 11. 31 fogli prestampati e 49 fogli bianchi DIN A5. Lampadine incluse. Possibilità di integrare con 80 fogli bianchi.

💡 205 W Halogen, 4200 lm, 3000 K, 2000 h/52 W PAR 30 Flood 38°, 550 lm, 2800 K, 1500 h, EEC C 🌀 2 x E27 (125 V: 1 x E27, 1 x G9), max. 250/75 W, A++-E 📏 330/600 cm





### **24 Karat Blau** Axel Schmid 2005

Metall, Kunststoff, Gold. Optional einsetzbarer Reflektor. Die goldenen Blenden haben jeweils vier Bohrungen, mit denen sie an dem Stabkreuz in verschiedenen Winkeln aufgehängt werden können. Kabel und Stabkreuz in Rot oder Schwarz. Lieferung mit Leuchtmittel. ■ Metal, plastic, gold. Reflector for optional use. The golden shades have four holes each, with which they can be suspended on the rods in various angles. Cable and rods in red or black. Complete with bulb. ■ Métal, matière plastique, feuille d'or. Réflecteur optionnel. Les quatre écrans peuvent être suspendus dans différents angles et positions. Câble et tiges en rouge ou noir. Livrée avec ampoule. ■ Metallo, materiale sintetico, oro. Riflettore per uso opzionale. I quattro paralumi d'oro possono essere appesi sull'asta a croce in vari angoli e posizioni. Cavo e asta in rosso o nero. Lampadina inclusa.



### **24 Karat Blau M** Axel Schmid 2005

Material wie 24 Karat Blau. Lieferumfang: Zwei Verbindungselemente, Stabkreuz, Baldachin, Kabel, Fassung, zwei Blenden, Reflektor, Leuchtmittel. Ein Set vergrößert 24 Karat Blau um etwa eine Blendenbreite. Die Stabkreuze werden mit Verbindungselementen fixiert. Mehrere Sets ermöglichen eine individuelle Gestaltung von unterschiedlichen Gruppierungen. ■ Material same as 24 Karat Blau. Set includes: Two connectors, suspension rod, canopy, cable, socket, two shades, reflector, bulb. The set extends 24 Karat Blau about one shade's width. Connectors fix the suspension rods to each other. The use of several sets allows an individual layout in a variety of forms and sizes. ■ Même matériel que la 24 Karat Blau. Inclus: deux éléments de fixation, tige en forme de croix, baldachin, câble, douille, deux écrans, réflecteur, ampoule. Un set agrandit 24 Karat Blau d'environ un écran. Les tiges en forme de croix sont fixées par les éléments de fixation. Plusieurs sets permettent une forme personnelle et individuelle de 24 Karat Blau. ■ Materiale come 24 Karat Blau. Sono inclusi: due elementi di collegamento, asta a croce, rosone, cavo, portalampada, due paralumi, riflettore, lampadina. Un set consente di ampliare 24 Karat Blau della larghezza di un paralume circa. Le aste a croce vengono fissate mediante gli elementi di collegamento. L'impiego di più d'un set permette varie composizioni di forma e misura individuali.

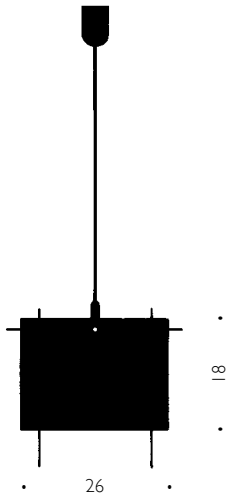

**24 Karat Blau**

max. 60 W (230 V: Halogen) E27 cable 230/450 cm

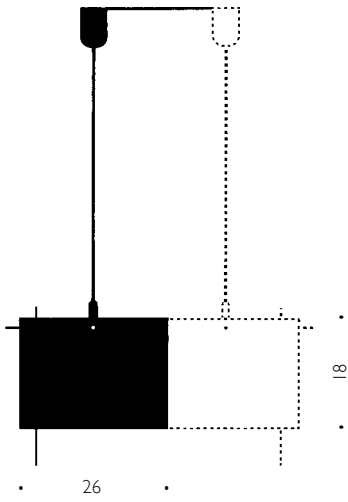

**24 Karat Blau M**

max. 60 W (230 V: Halogen) E27 cable 230/450 cm

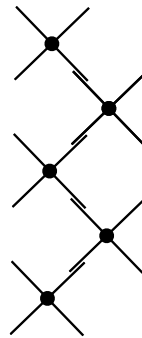
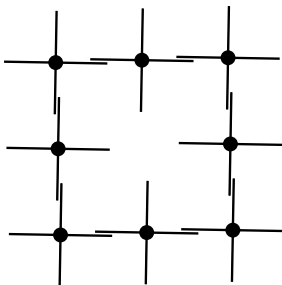





**Hot Achille** *Ingo Maurer und Team 1994*

Edelstahl, Aluminiumreflektor mit Schutzglas, Koaxialkabel. Für Raumhöhen bis 300 cm oder 350 cm. Lieferung mit Leuchtmittel. ■ Stainless steel, aluminium reflector with protective glass cover, coaxial cable. Complete with bulb. ■ Acier inoxydable, réflecteur en aluminium avec verre protecteur; câble coaxial. Adapté jusqu'à une hauteur de pièce de 300 cm ou 350 cm. Livrée avec ampoule. ■ Acciaio inossidabile, riflettore in alluminio con vetro di protezione, cavo coassiale. Per soffitti con altezza fino a cm. 300 o 350. Lampadina inclusa.







**SchlitZ Ingo Maurer 2002**

Aluminium, Glas. Up- und Downlights getrennt schaltbar. Abhängung an zwei Stahlseilen.

■ Aluminium, glass. Up- and downlights separately switchable. Suspension on two steel wires. ■ Aluminium, verre. Up et downlights à allumage séparé. Suspendue à deux fils d'acier. ■ Alluminio, vetro. Uplights e downlights comandabili separatamente. Sospesa a due fili d'acciaio.

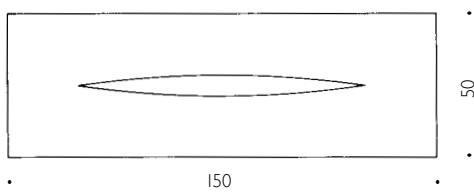
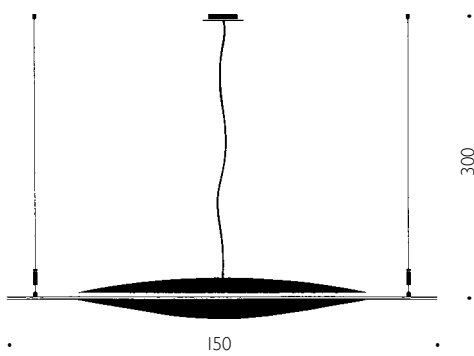



**Canned Light** *Christoph Matthias, Hagen Szezech 2003*

Aluminium, Edelstahl, Kunststoff. Eine Konservendose, befüllt mit Glühlampe, Reflektor, Fassung, Kabel und Schalter wird zur Hänge- oder Wandlampe. Aufputz-Montage mit Abdeckscheibe weiß Ø 8 cm. Stufenlos höhenverstellbar durch Umlenkrolle und Justier-ring. ■ Aluminium, stainless steel, plastic. A tin can, containing lightbulb, reflector, socket, cable and switch, turns into a hanging or wall lamp. Surface-mounted ceiling fixture with white baseplate cover Ø 8 cm. Height freely adjustable with pulley and ring. ■ Aluminium, acier inoxydable, matière plastique. Une boîte de conserves, contenant ampoule, réflecteur, douille, câble, interrupteur se transforme en suspension ou applique. Montage sur crépi avec rondelle blanche de recouvrement Ø 8 cm. Réglable en hauteur sans graduation par poulie de renvoi et anneau coulissant. ■ Alluminio, acciaio inossidabile, materiale sintetico. Un barattolo da conserva, contenente lampadina, portalampada, riflettore, cavo e interruttore, si trasforma in una lampada da sospensione o da parete. Scatola di derivazione esterna con piastra bianca di copertura Ø 8 cm. Regolazione continua dell'altezza con carrucola e anello di bloccaggio.

© 2003 and trademark by Campbell Soup Company used under license.  
All rights reserved.



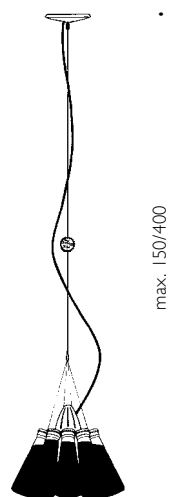

• 23 •

### **Campari Light** Raffaele Celentano 2002

Zehn originale Campari-Soda-Flaschen, einzeln abnehmbar, Kunststoff, Metall. Stufenlos höhenverstellbar durch Campari-Kronenkorken. Transparenter Baldachin, Ø 13 cm. Für Raumhöhen bis 300 cm, Sonderlänge für Raumhöhen bis 550 cm. Lieferung mit Leuchtmittel. ■ Ten original Campari Soda bottles, individually detachable. Plastic, metal. Height freely adjustable via Campari bottle cap. Transparent canopy, Ø 13 cm. For ceiling heights up to 300 cm. Special length for ceiling heights up to 550 cm. Complete with bulb. ■ Dix bouteilles originales de Campari Soda, détachables individuellement, matière plastique, métal. Réglable en hauteur sans graduation par une capsule Campari. Baldaquin transparent, Ø 13 cm. Pour hauteur de pièce jusqu'à 300 cm. Longueur spéciale pour hauteur de pièce jusqu'à 550 cm. Livrée avec ampoule. ■ Dieci bottiglie di Campari Soda originali, staccabili singolarmente, materiale sintetico, metallo. Altezza regolabile in continuo mediante un tappo Campari. Rosone trasparente, Ø 13 cm. Per soffitti con altezze fino a 300 cm. Lunghezza speciale per soffitti fino a 550 cm. Lampadina inclusa.

💡 52 W PAR 30 Flood 38° Halogen, 550 lm, 2800 K, 1500 h, EEC C

💡 E27 (125 V: G9), max. 75 W, A++-E





**Max. Up & Down** Ingo Maurer 2003

Aluminium, Metall, Kunststoff, Silikon. In einem Bereich von ca. 50 cm stufenlos höhenverstellbar durch einen Aufrollmechanismus im Baldachin. Reflektor in Weiß oder Aluminium Hochglanz. Lieferung mit Leuchtmittel. ■ Aluminium, metal, plastic, silicone. In a limited range of approx. 50 cm freely adjustable in height by means of a coiling mechanism integrated in the canopy. Reflector in white, or highly polished aluminium. Complete with bulb. ■ Aluminium, métal, matière plastique, silicone. Réglable en hauteur sans graduation sur environ 50 cm par un mécanisme d'enroulement intégré dans le baldaquin. Réflecteur en blanc ou aluminium poli. Livrée avec ampoule. ■ Alluminio, metallo, materiale sintetico, silicone. Regolazione continua dell'altezza entro un margine di ca. 50 cm grazie ad un meccanismo di avvolgimento all'interno del rosone. Riflettore in bianco o alluminio lucido. Lampadina inclusa.





**Öff Öff** Ingo Maurer und Team 1996

Porzellan glasiert, Metall. Stufenlos höhenverstellbar. Die Lampe kann in 6 Stufen in ihrer Neigung verstellt werden. Baldachin in Porzellan, Ø 8 cm. Für Raumhöhen bis 300 oder 550 cm. Lieferung mit Leuchtmittel. ■ Glazed porcelain, metal. Height freely adjustable. Tilttable in 6 stages. Porcelain canopy Ø 8 cm. For ceiling heights up to 300 or 550 cm. Complete with bulb. ■ Porcelaine glacée, métal. Réglage en hauteur sans graduation. Inclinaison en 6 graduations. Baldaquin Ø 8 cm en porcelaine. Pour hauteurs de plafond jusqu'à 300 ou 550 cm. Livrée avec ampoule. ■ Porcellana vetrificata, metallo. Regolazione continua dell'altezza. L'inclinazione della lampada è regolabile in sei posizioni prefissate. Rosone Ø cm. 8 in porcellana. Per altezze di soffitto fino a cm. 300 o 550. Lampadina inclusa.



**aTool** *Christoph Matthias 2003*

Aluminium, Edelstahl, Kunststoff. An drei Seilen aufgehängt. Innerhalb der Aufhängepunkte stufenlos höhenverstellbar und in alle Richtungen zu verschieben. Aufhängepunkte nach Wahl. Leuchtenkopf um 360° dreh- und um 45° schwenkbar. Der Reflektor ist außen matt grau lackiert. Lieferung mit Leuchtmittel. ■ Aluminium, stainless steel, plastic. Suspended on three wires. Freely adjustable in height and width within the lamp's suspension points. Free choice of suspension points. Head of lamp rotates through 360° and tilts through 45°. The reflector has a mat grey finish. Complete with bulb. ■ Aluminium, acier inoxydable, matière plastique. Suspendue à trois fils. Hauteur réglable sans graduation entre les points de fixation. Se déplace dans toutes les directions. Points de fixation au choix. Tête de lampe rotative à 360° et orientable à 45°. La face extérieure du réflecteur est vernie en gris mat. Livrée avec ampoule. ■ Alluminio, acciaio inossidabile, materiale sintetico. Sospesa a tre cavi. Regolazione continua dell'altezza entro i punti di fissaggio. Orientabile in tutte le direzioni. Punti di fissaggio a scelta. Il riflettore ruota di 360°, e si inclina di 45°. La superficie esterna del riflettore è verniciata grigio opaco. Lampadina inclusa.

 150 W Halogen, 2900 K, 2870 lm, 2000 h, EEC D

 B15d, max. 150 W, A++-E  300/500 cm

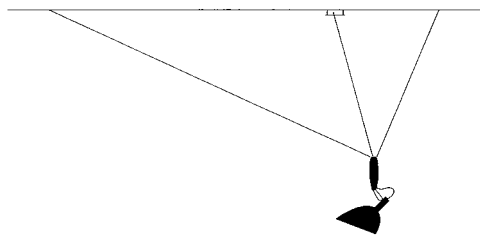
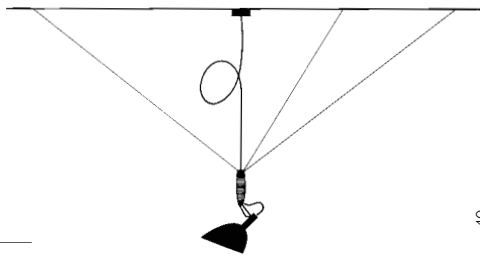
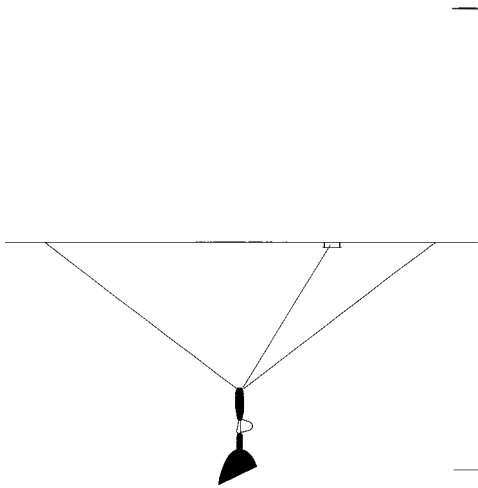

- 40
- min. 80, max. 240



**Max. Mover** Ingo Maurer und Team 2000

Aluminium, Fibreglas. Das Teleskop ist von 110 auf 210 cm ausziehbar. Durch die Aufhängung an Nylonseilen ist Max. Mover in der Höhe zu verstellen und um 180° drehbar. An seinem Griff kann der Reflektor in zwei Richtungen stufenlos eingerichtet werden. Lieferung mit Leuchtmittel. ■ Aluminium, fibreglass. The telescopic arm extends from 110 to 210 cm, the nylon suspension wires allow for height adjustment and the lamp can be rotated through 180°. The reflector is freely adjustable in two directions, using the handle. Complete with bulb. ■ Aluminium, fibre de verre. Le télescope est extensible de 110 à 210 cm. Suspendu à des fils de nylon, Max. Mover est réglable en hauteur et rotatif à 180°. Grâce à sa poignée, le réflecteur peut être réglé sans graduation dans deux directions. Livrée avec ampoule. ■ Alluminio, vetroresina. Il braccio telescopico è allungabile da cm. 110 a cm. 210. Essendo sospesa a fili di nylon, Max. Mover è regolabile in altezza e ruota di 180°. Agendo sulla leva, il riflettore può essere regolato in continuo in due direzioni. Lampadina inclusa.

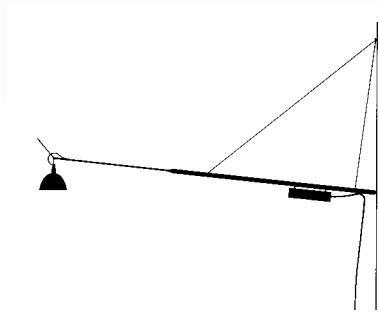
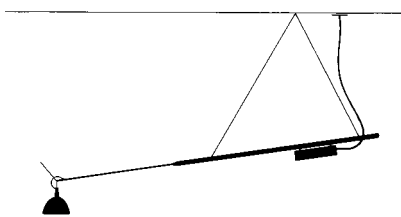

110-210

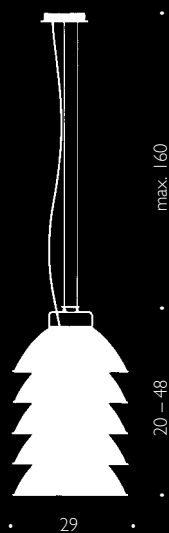

### **Five Pack Axel Schmid 2007**

Stahl. Fünf Reflektoren außen matt weiß, innen gelb bzw. weiß lackiert. Lichteffect durch Verstellen des Abstands der Reflektoren variabel. Für Raumhöhen bis 300 cm. Sonderlängen auf Anfrage. Lieferung mit Leuchtmitteln. ■ Steel. Five reflectors exterior mat white, interior yellow respectively white lacquer. Light effect variable by adjusting the spacing between the reflectors. For ceiling heights up to 300 cm. Alternative lengths available on request. Complete with bulbs. ■ Acier. Cinq réflecteurs: extérieur vernis blanc mat, intérieur vernis jaune et blanc. Effet lumineux variable pour régler la distance entre les réflecteurs. Pour hauteurs de pièce jusqu'à 300 cm. Longueurs spéciales sur demande. Livrée avec ampoules. ■ Acciaio. Cinque riflettori superficie esterna verniciata bianca opaca, superficie interna verniciata giallo e bianco. Regolando i riflettori varia l'atmosfera luminosa. Per soffitti con altezze fino a 300 cm. Lunghezze speciali su richiesta. Lampadine incluse.

 230 V: 2 x 42 W Halogen, 630 lm, 2000 h, EEC C

 E14 (125 V: G9), max. 60 W, A++-E  170 cm

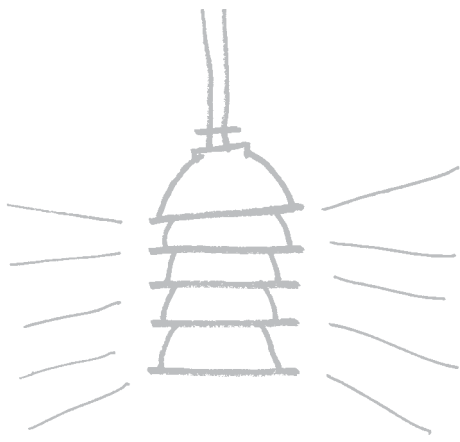
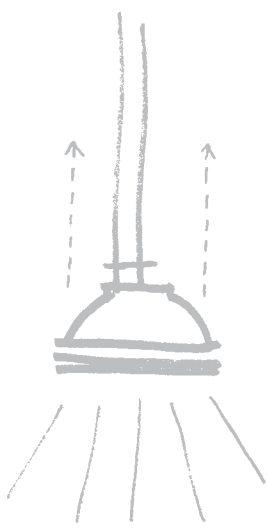



**Fly Candle Fly!** *Georg Baldele und Team 1996*

Wachskerze mit Aufhängeseil, 3 m Verlängerung und Tropfenfänger. Länge 30 cm. Brenndauer ca. 20 Stunden. ■ Wax candle with suspension wire, 3 m extension and dripcatcher. Length 30 cm. Burns for approx. 20 hours. ■ Bougie de cire avec câble de suspension, 3 m de rallonge et attrape-gouttes. Longueur 30 cm. Durée de combustion env. 20 heures. ■ Candela in cera con filo di sospensione, filo di prolungamento di m. 3 e raccogliatore di gocce. Lunghezza cm. 30. Durata ca. 20 ore.





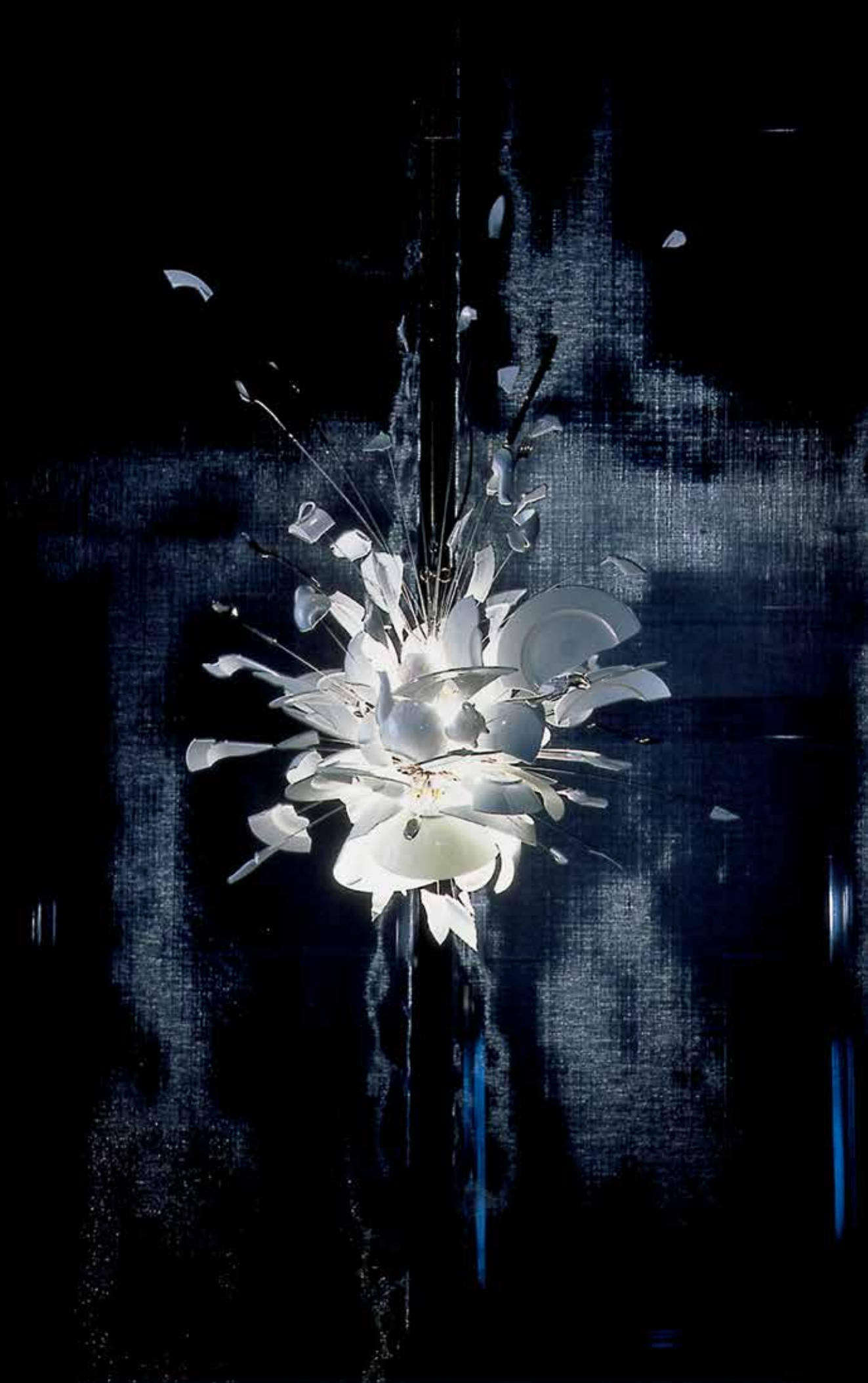

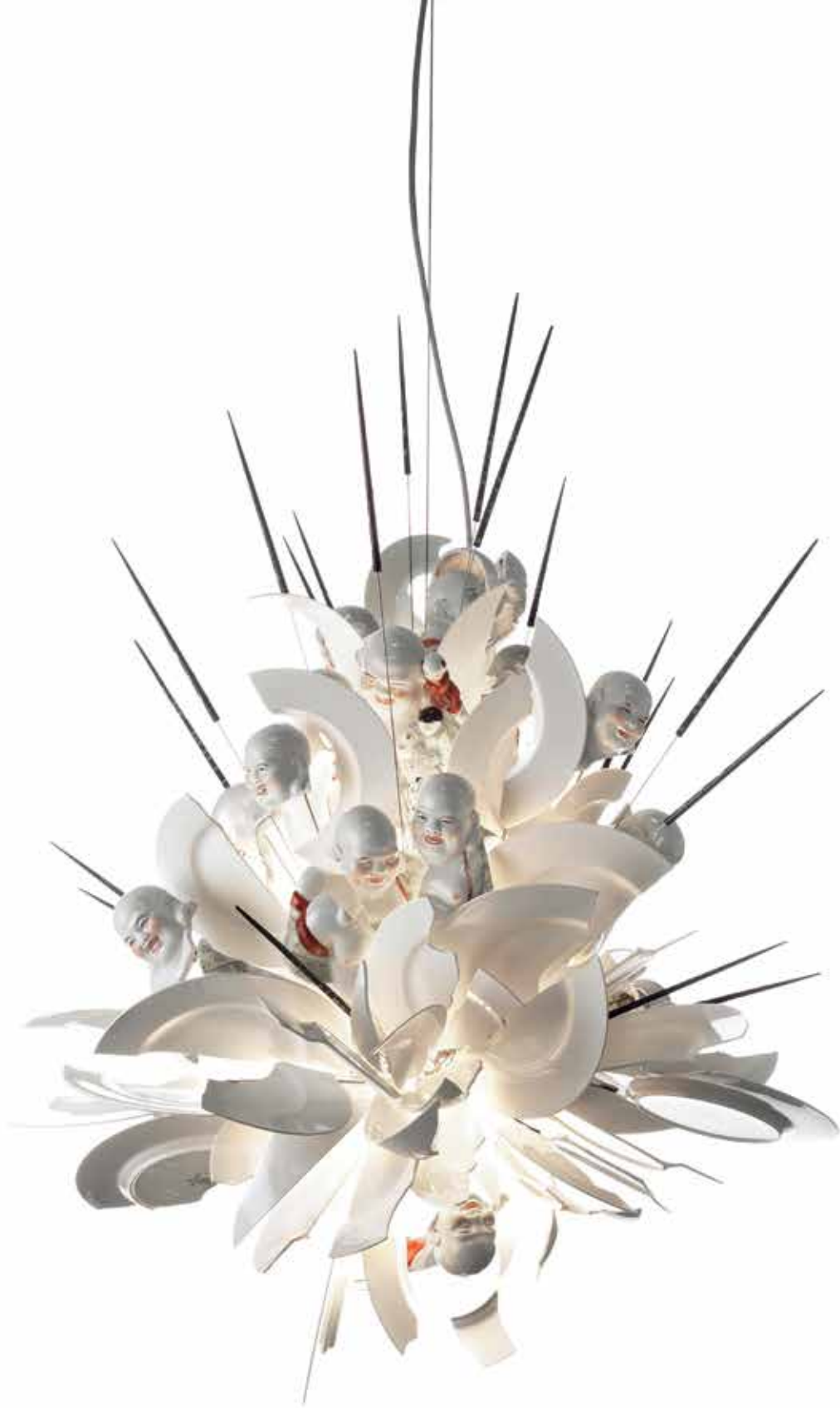

**Porca Miseria!** *Ingo Maurer 1994*

Limitierte Produktion. Nähere Angaben auf Anfrage. ■ Limited production. Please contact us for more detailed information. ■ Production limitée. Indications plus détaillées sur demande. ■ Produzione limitata. Informazioni dettagliate su richiesta.

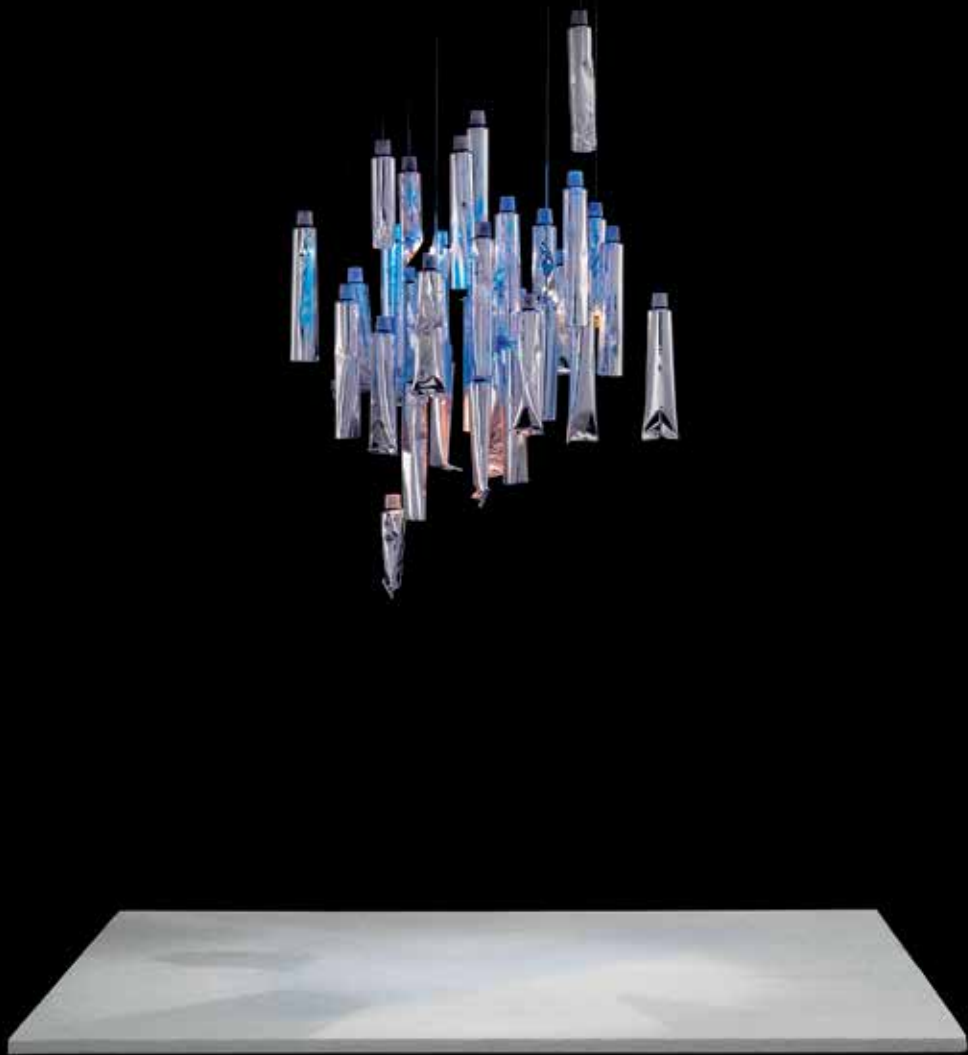

**Tu-Be I** Ingo Maurer, Ron Arad 2007

36 Aluminium-Tuben, Stahl, Kunststoff. Für Raumhöhen bis 350 cm. Lieferung mit Leuchtmitteln und zwei Ersatztuben. ■ 36 aluminium tubes, steel, plastic. For ceiling heights up to 350 cm. Complete with bulbs and 2 spare tubes. ■ 36 tubes d'aluminium, acier, matière plastique. Pour hauteurs de pièce jusqu'à 350 cm. Livrée avec ampoules et deux tubes de remplacement. ■ 36 tubi in alluminio, acciaio, materiale sintetico. Per soffitti con altezze fino a 350 cm. Lampadine e 2 tubi di ricambio inclusi.

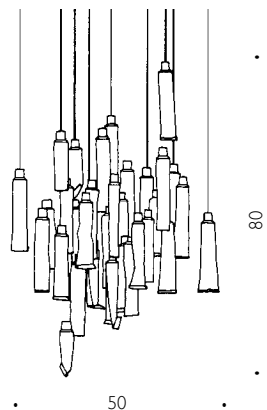



**Tu-Be Lüster** Ingo Maurer, Ron Arad 2007

93 Aluminium-Tuben, Stahl, Kunststoff. Für Raumhöhen bis 350 cm. Lieferung mit Leuchtmitteln und drei Ersatztuben. ■ 93 aluminium tubes, steel, plastic. For ceiling heights up to 350 cm. Complete with bulbs and 3 spare tubes. ■ 93 tubes d'aluminium, acier, matière plastique. Pour hauteurs de pièce jusqu'à 350 cm. Livrée avec ampoules et trois tubes de remplacement. ■ 93 tubi in alluminio, acciaio, materiale sintetico. Per soffitti con altezze fino a 350 cm. Lampadine e 3 tubi di ricambio inclusi.

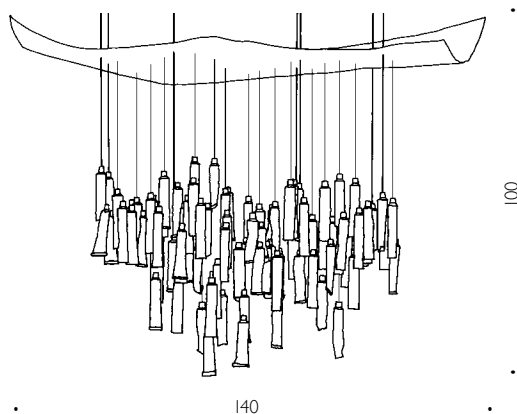





### **Knitterling Ingo Maurer 1978**

Japanisches Papier, schwarzer Kunststoffbaldachin Ø 8 cm. Lieferung ohne Leuchtmittel.

■ Japanese paper, black plastic canopy Ø 8 cm. Bulb not included. ■ Papier japonais, baldachin en plasti-que noir Ø 8 cm. Livrée sans ampoule. ■ Carta giapponese, rosone in materiale sintetico nero Ø cm. 8. Lampadina non inclusa.

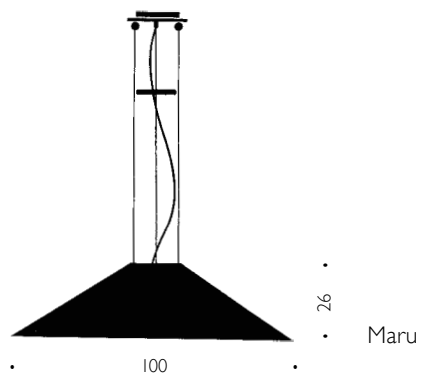
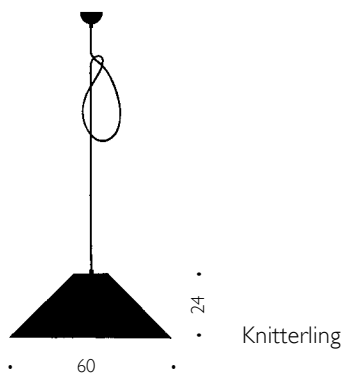
Alternative available with paper cover from below. See Maru.





 E27, max. 100 W, A++-E  200/450 cm black

Recommended retrofit LED bulb for 230 volts available through Ingo Maurer.



### **Maru** Ingo Maurer 1980

Schirm aus japanischem Papier, aufgehängt an drei dünnen Metallseilen, roter Eisenring für Höhenverstellung (Gegengewicht). Baldachin weiß lackiertes Metall Ø 22 cm. Lieferung ohne Glühlampe. Als gewolltes gestalterisches Element ist das Papier von Maru verknittert. ■ Japanese paper shade, suspended on three thin metal cables. Height adjustable with red iron ring, which serves as a counterweight. Metal canopy, white finish Ø 22 cm. The paper of Maru is crinkled. This is an intended design attribute. ■ Abat-jour en papier japonais, suspendu par trois câbles fins en métal, anneau en fer rouge pour régler la hauteur (contrepois). Baldaquin en métal laqué blanc Ø 22 cm. Livrée sans ampoule. Le papier pour Maru est froissé, ainsi voulu comme effet de style. ■ Paralume in carta giapponese, sostenuto da tre sottili fili metallici, anello rosso in ferro per la regolazione dell'altezza (contrappeso). Rosone in metallo verniciato bianco Ø cm. 22. Lampadina non inclusa. Una caratteristica voluta del design di Maru è l'effetto sgualcito della carta.

 E27, max. 150 W, A++-E  200/450 cm white

Recommended retrofit LED bulb for 230 volts available through Ingo Maurer.







Available in three sizes.

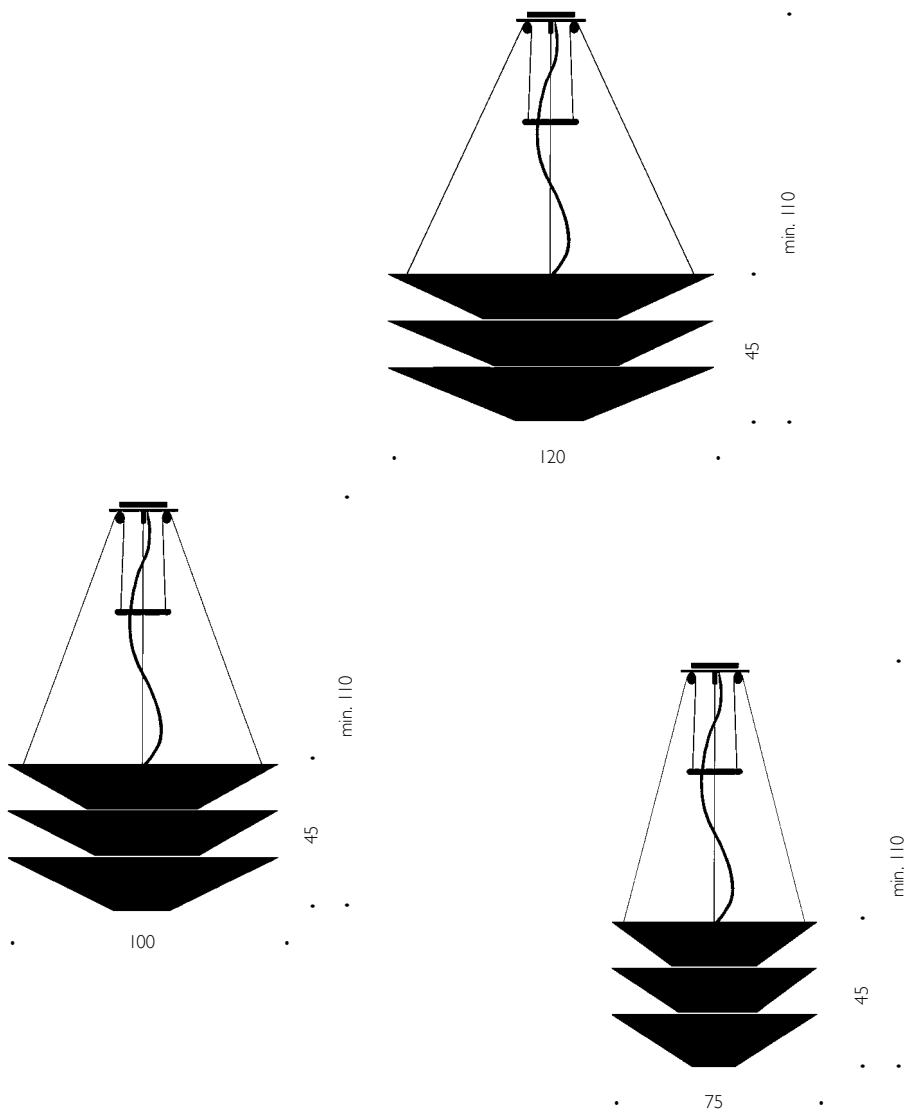

### **Floatation** Ingo Maurer 1980

Drei Schirme aus japanischem Papier, aufgehängt an dünnen Metallseilen, roter Eisenring für Höhenverstellung (Gegengewicht), Baldachin weiß lackiertes Metall Ø 22 cm. Lieferung ohne Glühlampen. Die Schirme können einzeln ausgewechselt werden. ■ Three Japanese paper shades, suspended on thin metal cables. Height adjustable with red enamelled iron ring, which serves as a counterweight. Metal canopy, white finish Ø 22 cm. Bulbs not included. Shades separately replaceable. ■ Trois éléments abat-jour en papier japonais suspendus par des câbles fins en métal, anneau rouge en fer pour régler la hauteur (contrepois), baldachin en métal laqué blanc Ø 22 cm. Livrée sans ampoules. Les abat-jour peuvent être remplacés séparément. ■ Tre paralumi in carta giapponese, sostenuti da sottili fili metallici, anello rosso in ferro per la regolazione dell'altezza (contrappeso), rosone in metallo verniciato bianco Ø cm. 22. Lampadine non incluse. I paralumi possono essere sostituiti singolarmente.

 E27, 1 x PAR 30 max. 100 W, 2 x max. 60 W, 2 x max. 40 W  200/450 cm white

Recommended retrofit LED bulb for 230 volts available through Ingo Maurer.

Das Papier von Floatation, Knitterling, Maru und der Tischlampe Lampampe ist als gewolltes, gestalterisches Element verknittert. Es reagiert auf Schwankungen der Luftfeuchtigkeit. Dadurch kann sich die Spannung der Schirme verändern. Diese Lampen sind nicht geeignet für Räume mit hoher Luftfeuchtigkeit.

The paper of Floatation, Knitterling, Maru and the table lamp Lampampe is crinkled. This is an intended design attribute. The material reacts to fluctuations from humidity. Therefore, changes in the rigidity of the shades can not be prevented. These lamps are not suited for environments with high humidity.

Le papier pour Floatation, Knitterling, Maru et la lampe de table Lampampe est froissé, ainsi voulu comme effet de style. Le matériel très sensible réagit à l'humidité ambiante. Aussi le papier peut légèrement se détendre. Ces produits ne sont pas appropriés pour des pièces avec un fort taux d'humidité.

Una caratteristica voluta del design di Floatation, Knitterling, Maru e della lampada da tavolo Lampampe è l'effetto sgualcito della carta. Il materiale reagisce a oscillazioni dell'umidità. Modifiche della tensione della carta non sono, perciò, escluse. Questi prodotti non sono adatti all'uso in ambienti ad alta umidità.



### **Willydilly Ingo Maurer 1983**

Weißer transluzenter Karton. Kunststoff-Baldachin Ø 9 cm weiß, fluoreszierende Halteklammer. Höhenverstellbar. Schirmform und -größe variabel. Lieferung ohne Glühlampe.

- White translucent cardboard. Plastic canopy Ø 9 cm white, with fluorescent clip. Height adjustable. Shape and size of shade can be varied as required. Bulb not included.
- Carton blanc translucide. Baldaquin en plastique Ø 9 cm blanc, pince fluorescente. Hauteur réglable. Forme et dimension de l'abat-jour variables. Livrée sans ampoule.
- Cartone bianco traslucido, rosone Ø cm. 9 bianco in materiale sintetico, molletta fluorescente. Altezza regolabile. Forma e dimensione del paralume varabili. Lampadina non inclusa.

 E27, max. 60 W, A++-E  200/450 cm

Recommended retrofit LED bulb for 230 volts available through Ingo Maurer.



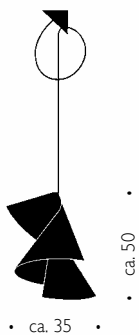



## Now in fluorescent pink or orange and in white

### **Willydilly Bon** *Ingo Maurer 1983*

Weißer transluzenter Karton, innen Leuchtorange oder -pink. Kunststoff-Baldachin Ø 9 cm weiß, transparente Halteklammer. Höhenverstellbar. Schirmform variabel. Lieferung ohne Glühlampe.

■ White translucent cardboard, inside fluorescent orange or pink. Plastic canopy Ø 9 cm white, with transparent clip. Height adjustable. Shape and size of shade can be varied as required. Bulb not included. ■ Carton blanc translucide, intérieur en orange fluorescent ou pink fluorescent. Baldaquin en plastique Ø 9 cm blanc, pince transparente. Hauteur réglable. Forme de l'abat-jour variable. Livrée sans ampoule. ■ Cartone bianco traslucido, superficie interna arancione o pink fluorescente. Rosone Ø 9 cm bianco in materiale sintetico, molletta trasparente. Altezza regolabile. Forma del paralume variabile. Lampadina non inclusa.

 E27, max. 60 W, A++-E  200/450 cm

Recommended retrofit LED bulb for 230 volts available through Ingo Maurer.





**Savoie Donato Savoie, Ingo Maurer 1979**

Baldachin und Fassung aus weißem Porzellan. Silikon-Kabel. Glühlampe halb mattiert. Höhenverstellbar bis maximal 180 cm. Version 230 Volt mit Leuchtmittel. ■ Canopy and socket in white porcelain. Silicone cable. Bulb semi-frosted. Height adjustable (max. 180 cm). 230 volts version complete with bulb. ■ Baldaquin et douille en porcelaine blanche. Câble en silicone. Ampoule 60 demi-dépolie. Hauteur réglable jusqu'à une longueur de 180 cm au maximum. Version 230 volts livrée avec ampoule. ■ Rosone e portalampada in porcellana bianca. Cavo in silicone. Lampadina semi-opalizzata. Regolabile in altezza fino a una lunghezza massima di cm. 180. Versione 230 volt fornita con lampadina.





### **Grasl Jan Roth 1973**

Reflektor aus glanzeloxiertem Aluminium und Messing. Kabel mit Schalter und Stecker. Lieferung mit Glühlampe. Auch als Tischlampe. ■ Reflector: anodized aluminium, brass. Cable with switch and plug. Complete with bulb. Also available as table lamp. ■ Réflecteur en aluminium électrolysé et laiton. Câble avec interrupteur et prise de courant. Livrée avec ampoule. Egalement disponible comme lampe de table. ■ Riflettore in alluminio anodizzato e ottone. Cavo con interruttore e spina. Lampadina inclusa. Disponibile anche nella versione da tavolo.





Tischlampen / Table lamps / Lampes de table / Lampade da tavolo

## Prototypes for Arbeitslampe





WHAT WE DO  
COUNTS.

WHAT WE DO  
COUNTS

WHAT  
WE DO  
COUNTS.

WHAT WE DO  
COUNTS

I Ricchi Poveri – a new collection that has been on my mind for many, many years. Ideas for more members are spinning around in my head, inspiration comes from all sides.

I Ricchi Poveri, or I Poveri Ricchi – the Rich Poor or the Poor Rich – which is the title that fits better? What is on my mind is a group of objects with an unpretentious and simple yet highly powerful expression that comes straight from the heart and is embraced by the like-minded – whether rich or poor is quite irrelevant.

I Ricchi Poveri are a step beyond design and, at the same time, a statement for the timeless beauty and fascination of the light bulb.

I.M.

**Silber Bzzzz, limited edition of 50, 2014. Sold out.**



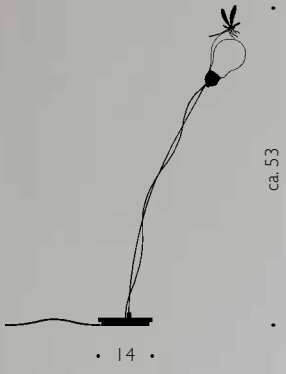

ca. 53

• 14 •

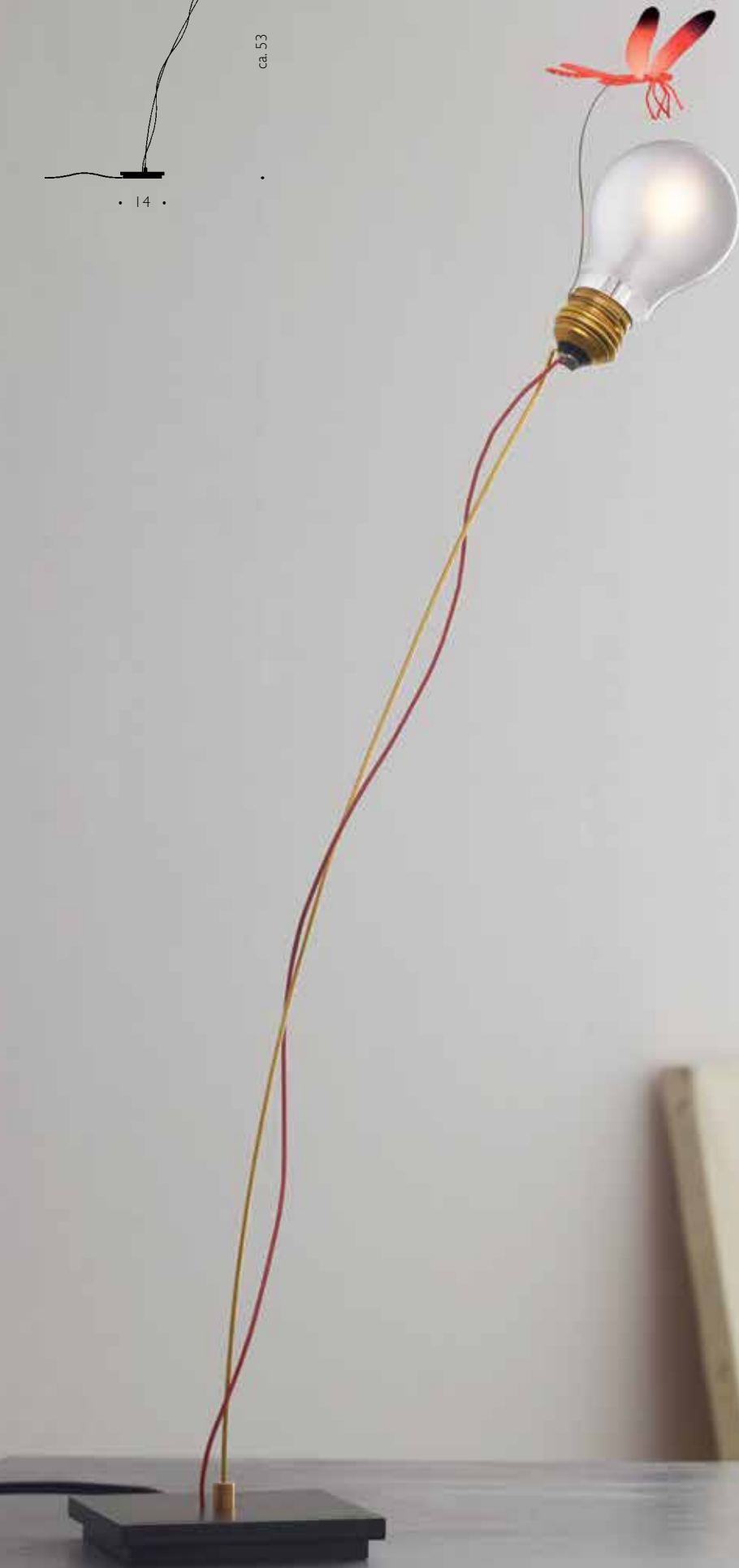



**Unlimited edition, laser cut anodised aluminum**

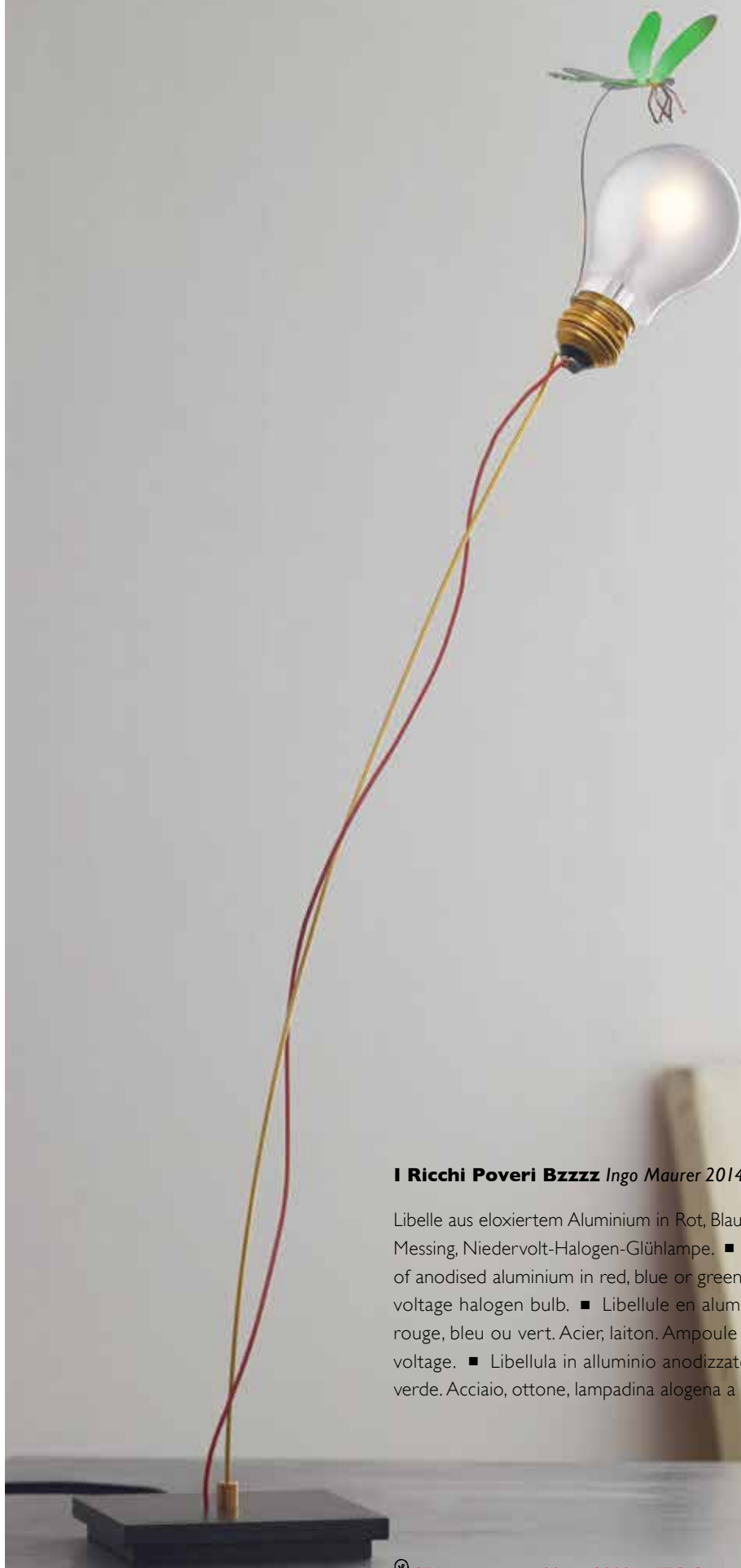

**I Ricchi Poveri Bzzzz** Ingo Maurer 2014

Libelle aus eloxiertem Aluminium in Rot, Blau oder Grün. Stahl, Messing, Niedervolt-Halogen-Glühlampe. ■ Dragonfly made of anodised aluminium in red, blue or green. Steel, brass, low-voltage halogen bulb. ■ Libellule en aluminium anodisé en rouge, bleu ou vert. Acier, laiton. Ampoule halogène à bas voltage. ■ Libellula in alluminio anodizzato in rosso, blu o verde. Acciaio, ottone, lampadina alogena a basso voltaggio.



35 W Halogen, 600 lm, 2000 h, EEC C



E27



230/125/24 V



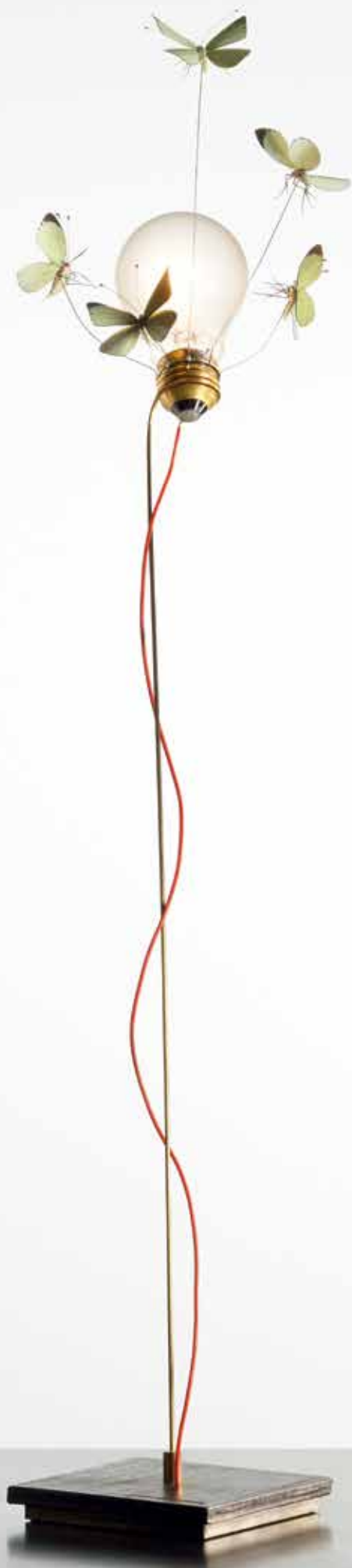

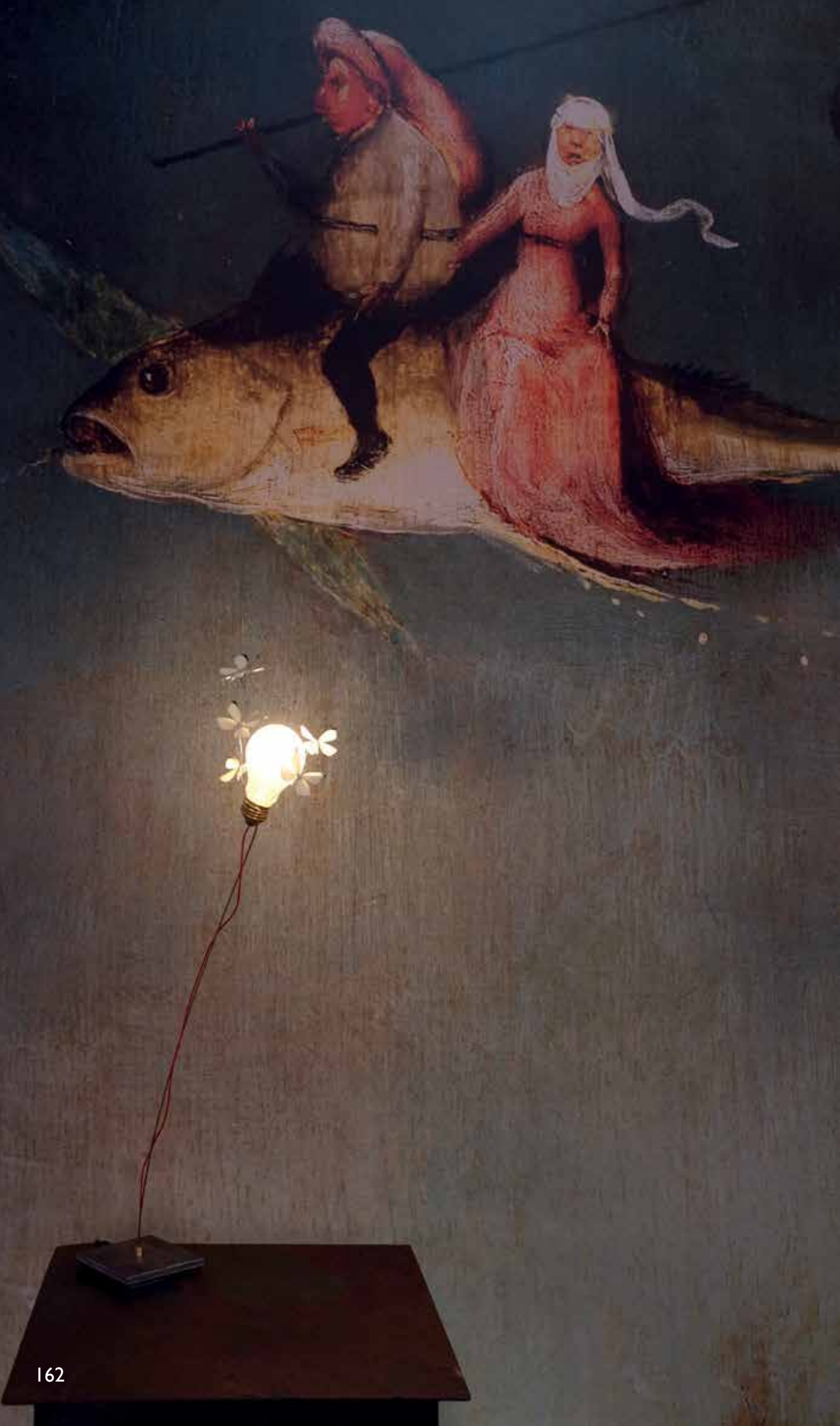

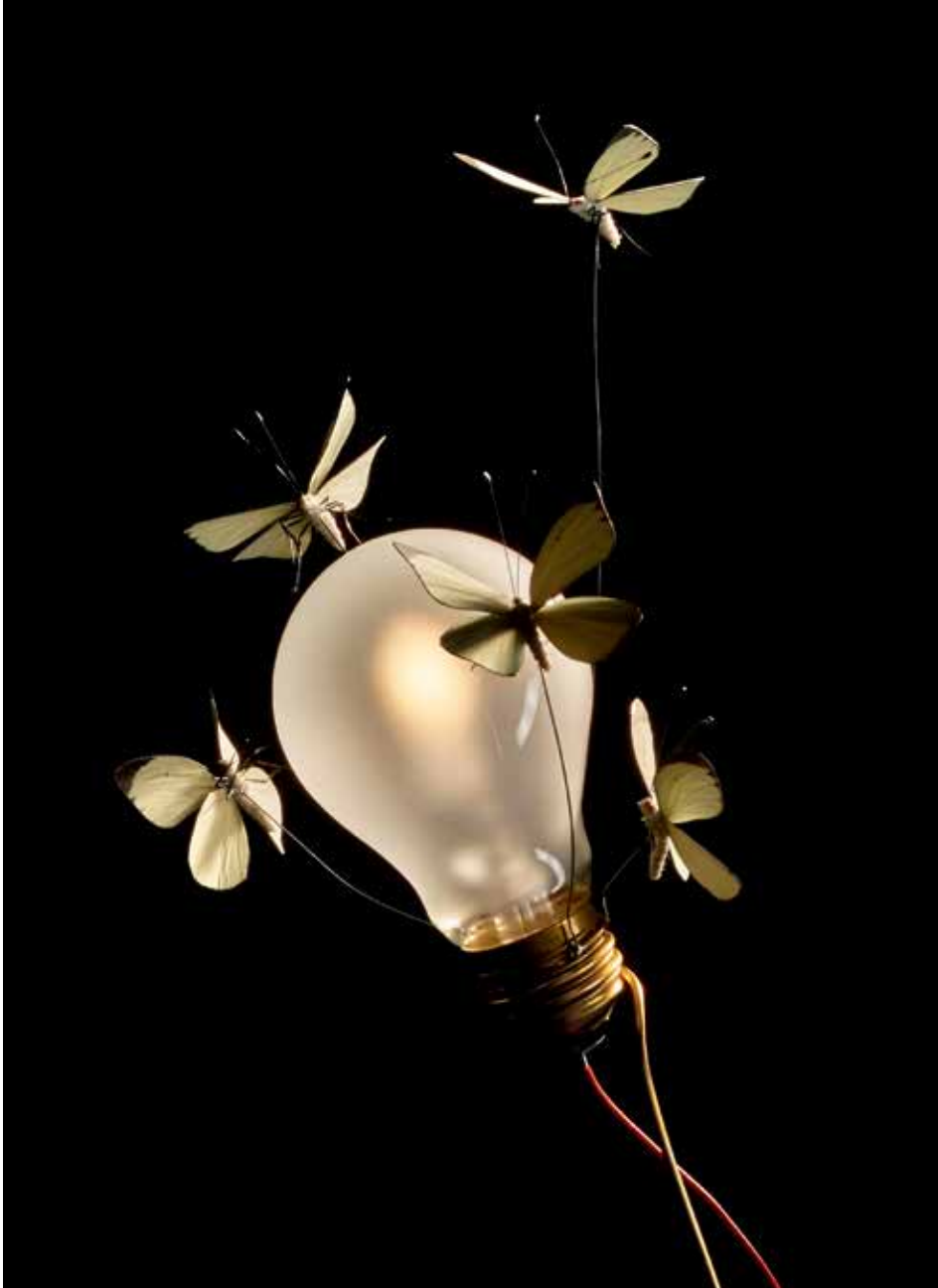

**I Ricchi Poveri Five Butterflies** Ingo Maurer 2014

Fünf handgefertigte Insektenmodelle, Stahl, Messing, Niedervolt-Halogen-Glühlampe. ■  
Five hand-made insect models, steel, brass, low-voltage halogen bulb. ■ Cinq modèles  
en insectes faits main, acier, laiton. Ampoule halogène à bas voltage. ■ Cinque modelli  
di insetti realizzati a mano, acciaio, ottone, lampadina alogena a basso voltaggio.

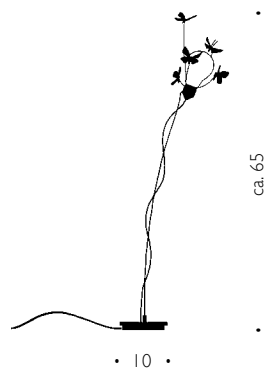





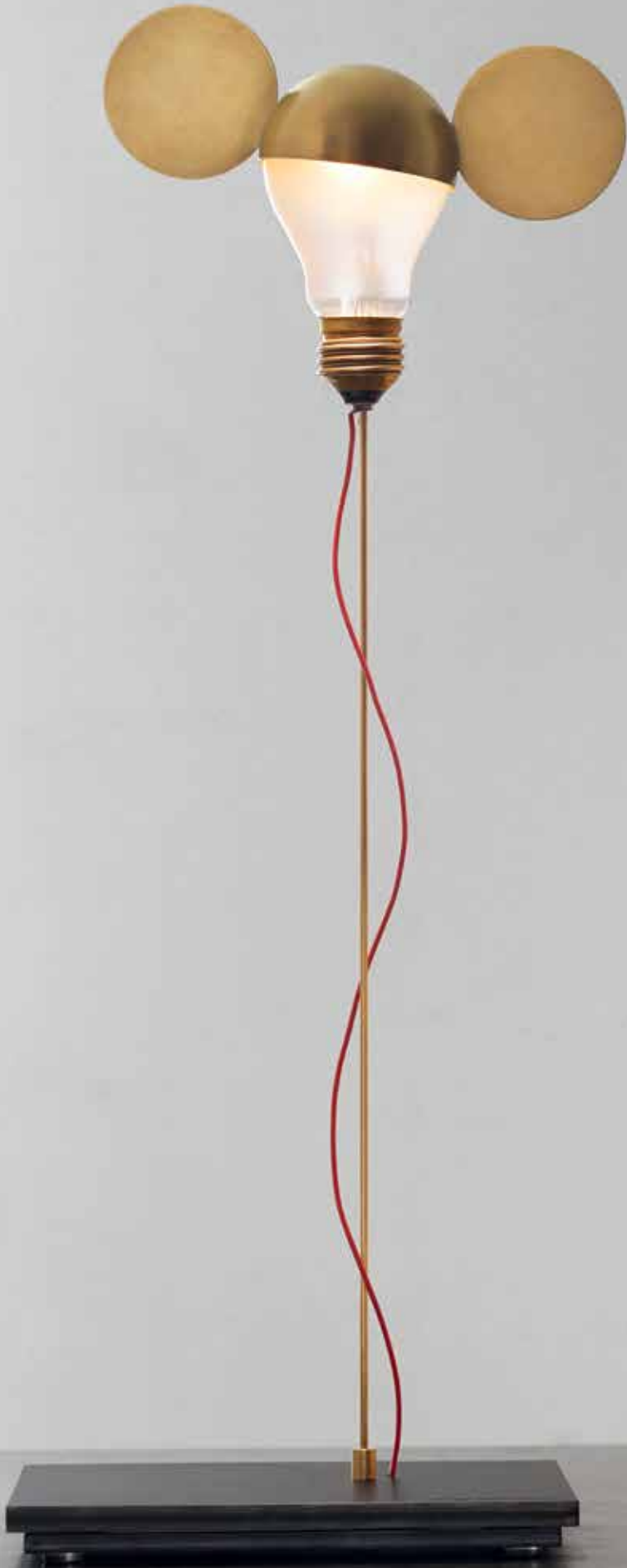



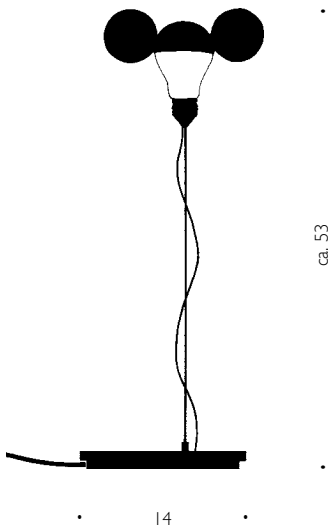



### **I Ricchi Poveri Toto** *Ingo Maurer 2014*

Stahl, Kappe aus lackiertem Messing, Niedervolt-Halogen-Glühlampe. ■ Steel, hood made of lacquered brass, low-voltage halogen bulb. ■ Acier, capuchon en laiton laqué. Ampoule halogène à bas voltage ■ Acciaio, cappello in ottone laccato, lampadina alogena a basso voltaggio.

 35 W Halogen, 600 lm, 2000 h, EEC C  E27  230/125/24V

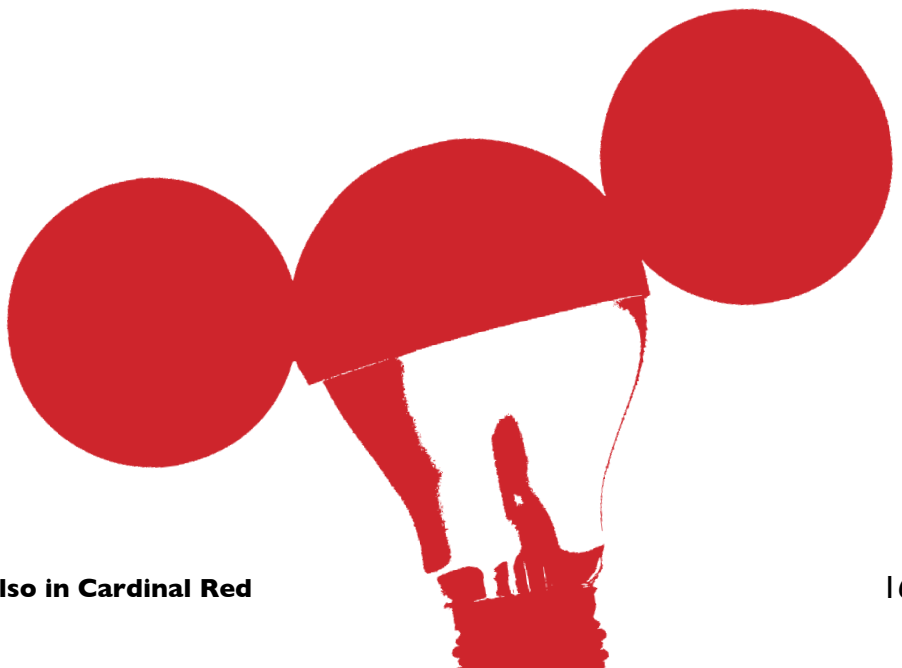

**Available also in Cardinal Red**









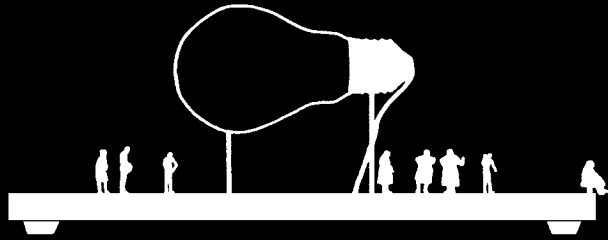

25

12

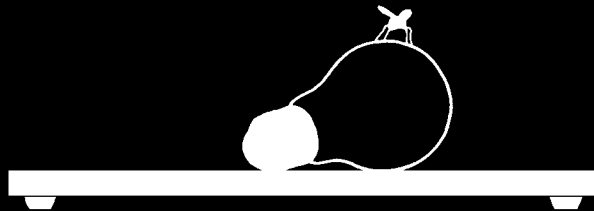



25

9,5



### **I Ricchi Poveri Monument for a Bulb** *Ingo Maurer 2014*

Acht Figuren aus Neusilber, Stahl, Messing, Niedervolt-Halogen-Glühlampe. ■ Eight figures in nickel silver, steel, brass, low-voltage halogen bulb. ■ Huit figurines en maillechort, acier, laiton. Ampoule halogène à bas voltage. ■ Otto figure in alpacca, acciaio, ottone, lampadina alogena a basso voltaggio.

 35 W Halogen, 600 lm, 2000 h, EEC C  E27  230/125/24 V

### **I Ricchi Poveri Fly** *Ingo Maurer 2014*

Limitierte Auflage. Stahl, handgefertigtes Fliegenmodell, LED. ■ Limited edition. Steel, hand-made model of a fly, LED bulb. ■ Edition limitée. Acier; modèle de mouche fait main, ampoule LED. ■ Edizione limitata. Acciaio, modello di mosca realizzato a mano, lampadina LED.

 3 W, 120 lm, 2500–2900 K, CRI 95, EEC A  110–240 V/19 V  250 cm





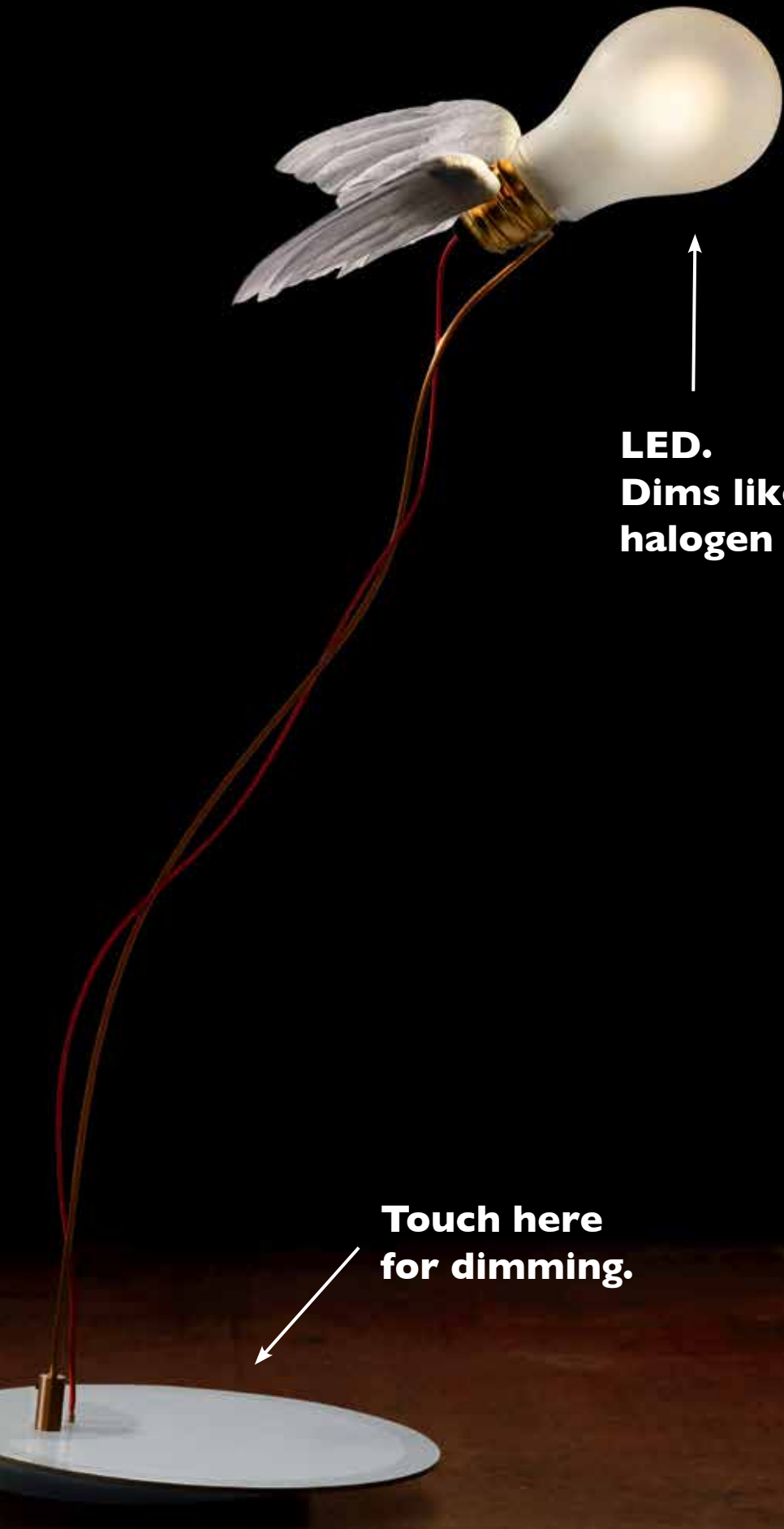

**LED.**  
**Dims like a**  
**halogen bulb.**

**Touch here**  
**for dimming.**

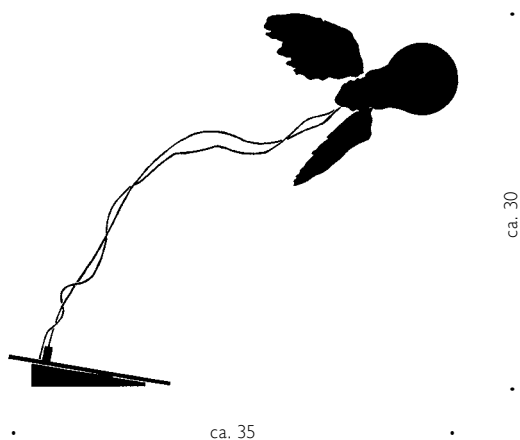

### **Lucellino LED** Ingo Maurer 2015

Messing, Glas, Kunststoff, handgefertigte Flügel aus Gänsefedern. Das LED-Leuchtmittel ist stufenlos dimmbar durch einen Sensor in der Fußplatte. Beim Dimmen ändert sich die Lichtfarbe wie bei einer Halogenleuchte. Das Leuchtmittel wird exklusiv für Ingo Maurer hergestellt. ■ Glass, brass, plastic, hand-crafted goose-feather wings. Continuously dimmable with a touch sensor on the base plate. The colour temperature changes from white to a warm red when dimmed down, just as a halogen bulb does. The LED bulb is produced exclusively for Ingo Maurer GmbH. ■ Verre, laiton, matière plastique, ailes confectionnées à la main en plumes d'oie. Avec interrupteur à sensor tactile pour allumer et faire varier l'intensité de la lumière sur la base en réglage continu. En faisant varier l'intensité lumineuse, la couleur de la lumière change, comme si on utilisait une ampoule halogène. L'ampoule LED est spécialement produit pour la société Ingo Maurer GmbH ■ Vetro, ottone, materiale sintetico, ali in piume d'oca lavorate a mano. Base sensoriale per accendere, spegnere e dimmerare (regolazione continua dell'intensità luminosa). Variando l'intensità luminosa della lampada, come per le lampadine alogene, cambia anche la tonalità di colore della luce. La lampadina LED è una produzione esclusiva per la Ingo Maurer GmbH.



**OH•LED•ONE** Ingo Maurer 2015

Glas, Edelstahl, Kunststoff. Oled Modul von LG Chem. Die Neigung der Lampe lässt sich über das Kugelgelenk am Fuß stufenlos einstellen. ■ Glass, stainless steel, plastic. OLED module by LG Chem. The angle of the lamp is freely adjustable by the ball-and-socket joint in the base. ■ Verre, acier inoxydable, matière plastique. Module OLED de LG Chem. L'inclinaison de la lampe est réglable sans graduation par l'articulation à rotule au niveau du socle. ■ Vetro, acciaio inossidabile, materiale sintetico. Modulo OLED di LG Chem. L'inclinazione della lampada può essere regolata mediante un giunto a sfera.

 7 W OLED, 500 lm, 3000 K, CRI 90  230/125/22 V





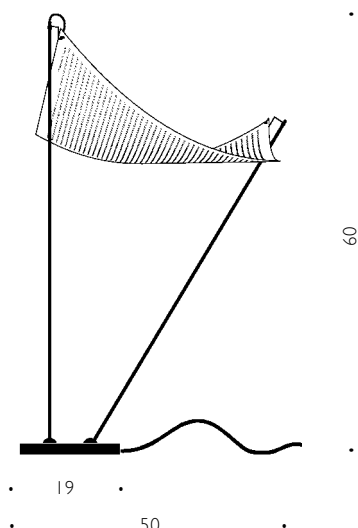

A magnificent new

LED high-tech development  
turned into poetry.

**Dew Drops Table** Ingo Maurer Team 2014

Transparente Kunststoffolie mit integrierten LEDs, Metall. Die Stäbe sind mit Kugelgelenken auf der Fußplatte (13x19 cm) montiert. Mit Sensorschalter zum Anschalten und Dimmen auf der Folie. ■ Transparent plastic sheet with integrated LEDs, metal. Two rods, adjustable via ball-joints mounted on the base (13x19 cm). With dimmable touch sensor switch on the sheet. ■ Film plastique transparent avec LEDs intégrés, métal. Les tiges sont montées grâce à une articulation à rotule sur la plaque (13x19 cm). Avec interrupteur à sensor tactile pour allumer et faire varier l'intensité de la lumière sur le film plastique. ■ Pellicola trasparente in materiale sintetico con LED integrati, metallo. Le due aste sono fissate alla base (13x19 cm) tramite giunti a sfera. Interruttore a sensore sulla pellicola stessa per accendere, spegnere e dimmerare.

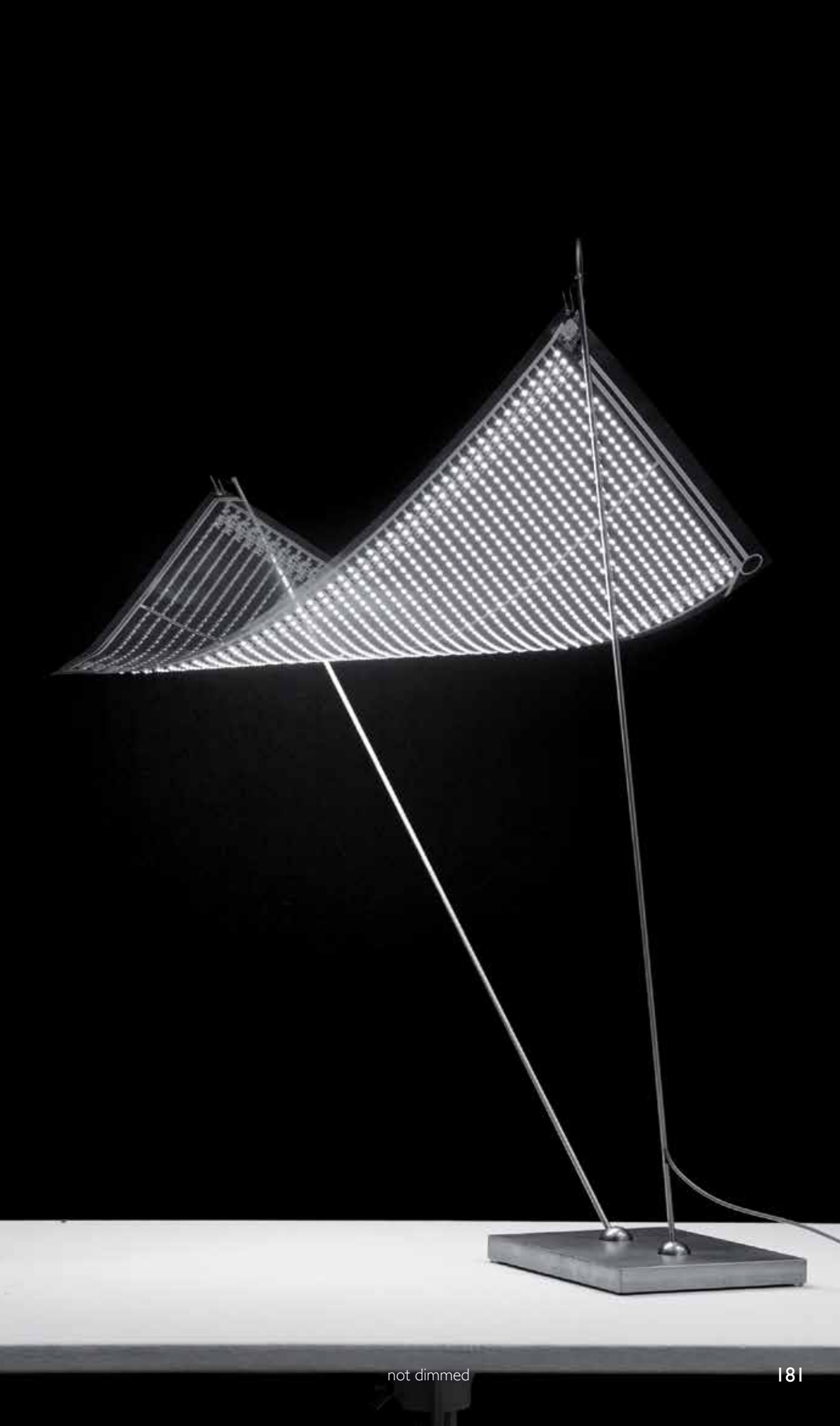

not dimmed

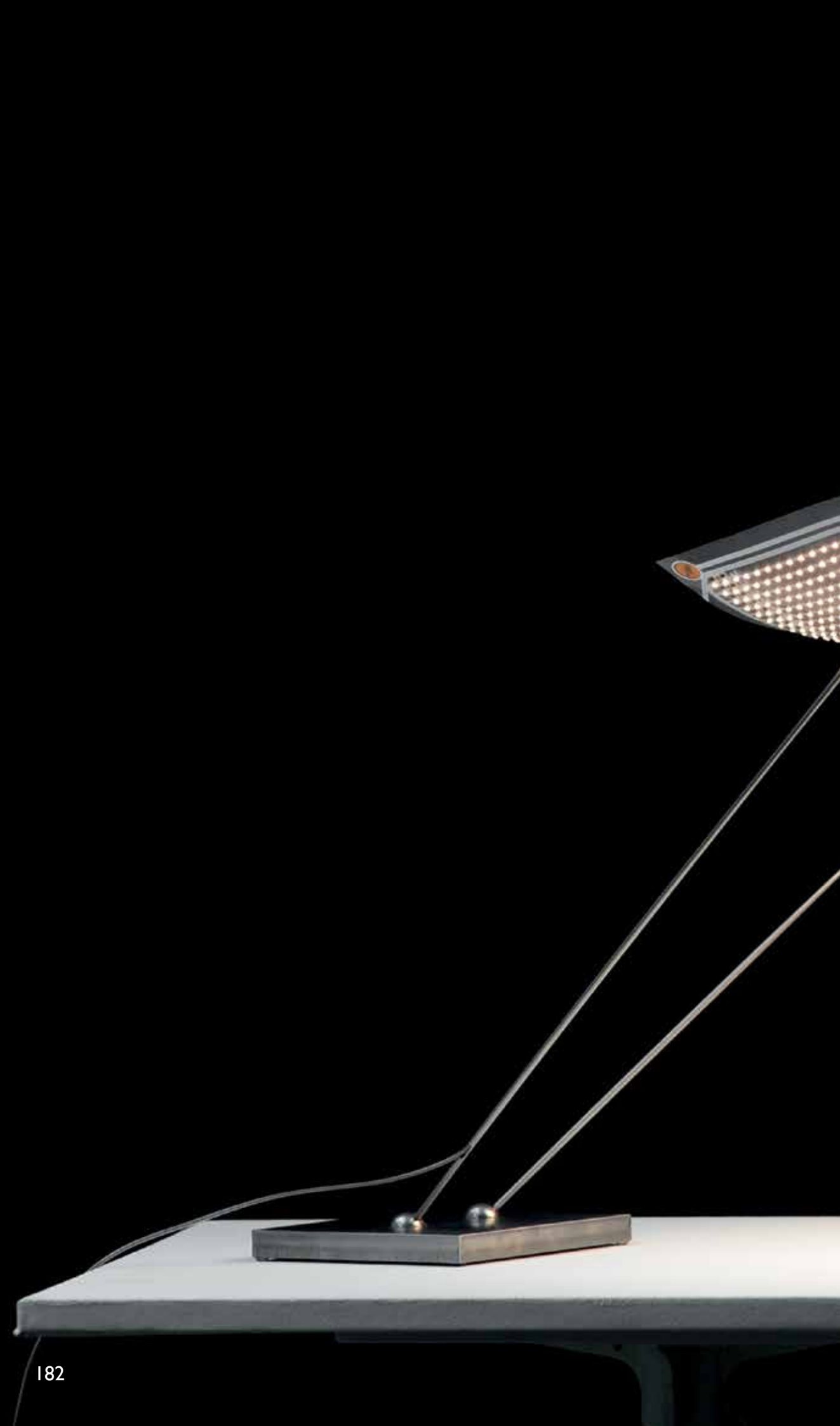



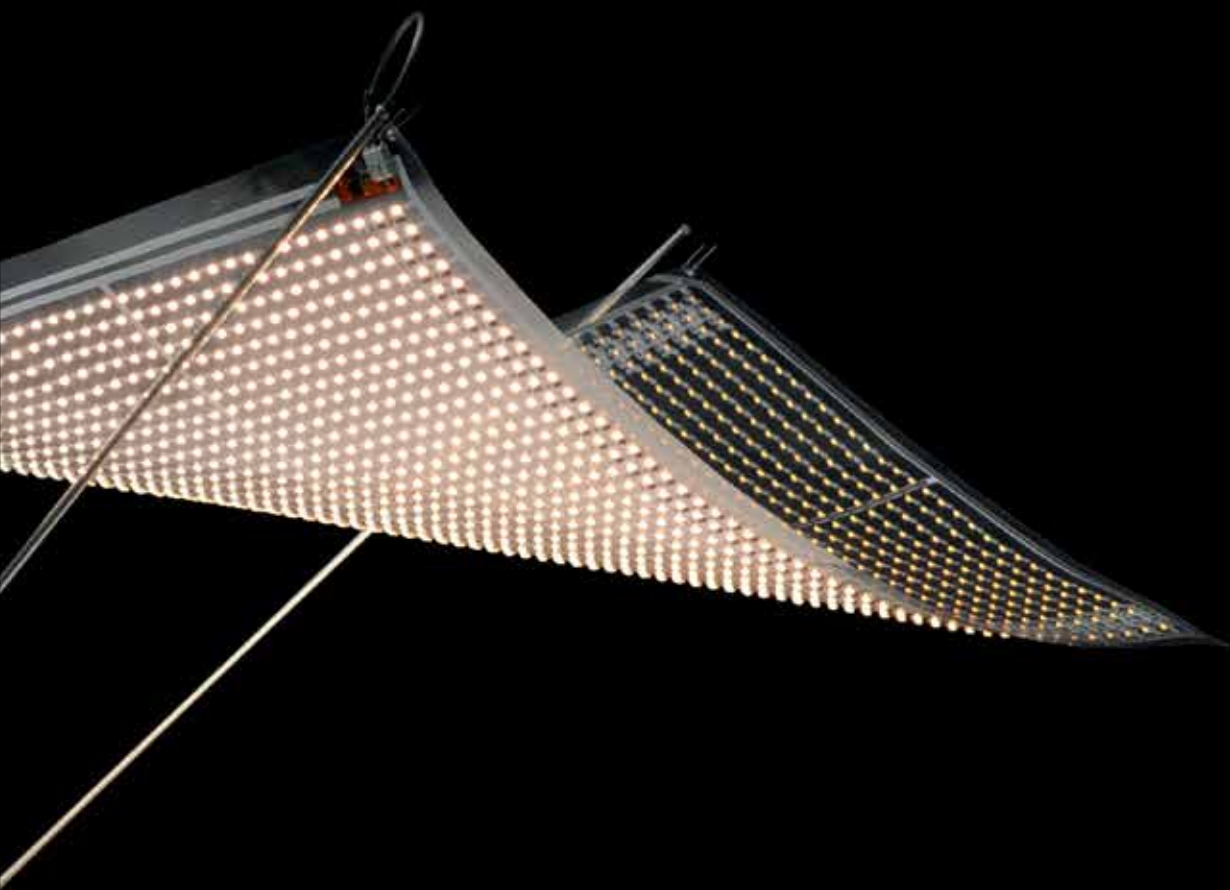



# BASTARDO

max. 73

max. 100

50

22





**Bastardo is based  
on Prototype.  
Bernhard Dessecker  
and Ingo Maurer.  
Coming soon.**

**Bastardo Floor** Bernhard Dessecker/Ingo Maurer 2015

Aluminium, Metall, Silikon, Kunststoff. Die Neigung der Lampe lässt sich über das Kugelgelenk am Fuß einstellen. ■ Aluminium, metal, silicone, plastic. The angle of the lamp is adjustable by the ball-and-socket joint in the base. ■ Aluminium, métal, silicone, matière plastique. L'inclinaison de la lampe est réglable par l'articulation à rotule au niveau du socle. ■ Alluminio, metallo, silicone, materiale sintetico. L'inclinazione della lampada può essere regolata mediante un giunto a sfera.

 15 W LED, 1300 lm, 2700 K, CRI >90, dimmable, A+



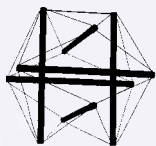

### Light Structure Peter Hamburger, Ingo Maurer 1970/2013

Plexiglas, Acryl, Aluminium. Sechs oder drei Röhren, von Kabeln in Spannung gehalten. Tischversion: Schnurtrafo mit Drehdimmer. Hängeversion: mit integriertem Transformator, dimmbar. Die LED-Röhren, Ø 2,5 cm, können nicht als Ersatzteil für die frühere Version der Light Structure (1970) verwendet werden. ■ Plexiglass, acrylic, aluminium. Six or three tubes, connected and held in tension by insulated wires. Table version: with continuously rotating transformer-dimmer. Hanging version: with integrated transformer, dimmable. The LED tubes, Ø 2.5 cm, can not be used as spare part for the former version of Light Structure (1970). ■ Plexiglas, acrylique, aluminium. Six ou trois tubes, connectés et tenues en tension aux câbles. Version pour table: avec transformateur à cordon avec variateur à rotation. Version pour suspension: avec transformateur intégré, dimmable. Les tubes LED, Ø 2,5 cm, ne peuvent pas être utilisés comme pièce de rechange pour la version originale de Light Structure (1970). ■ Plexiglas, acrilico, alluminio. Sei o tre tubi collegati e tenuti in tensione da cavi isolati. Versione da tavolo: con trasformatore su cavo con dimmer a anopola rotante. Versione a sospensione: con trasformatore integrato, dimmerabile. I tubi LED, Ø 2,5 cm, non possono essere usati come pezzo di ricambio per la versione originale di Light Structure (1970).

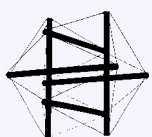
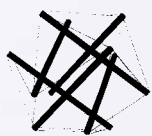

12 or 6 LEDs, each 3,4 W, 3600 lm, 2700 K, CRI 80



230/125/40 V



250 cm

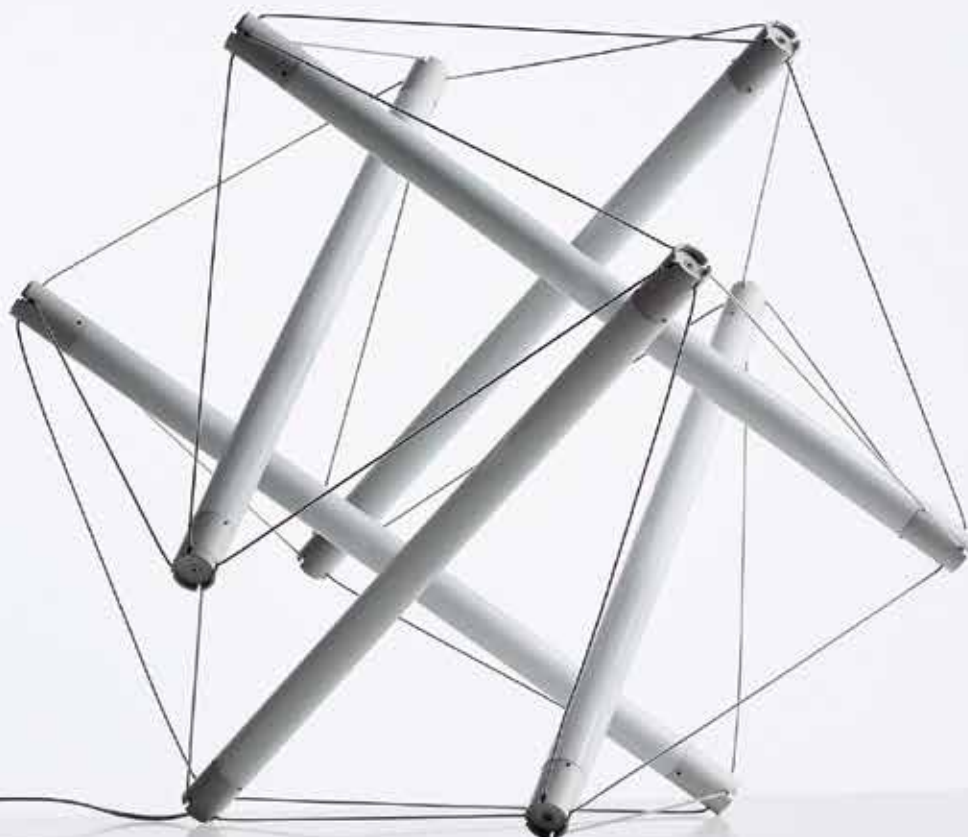

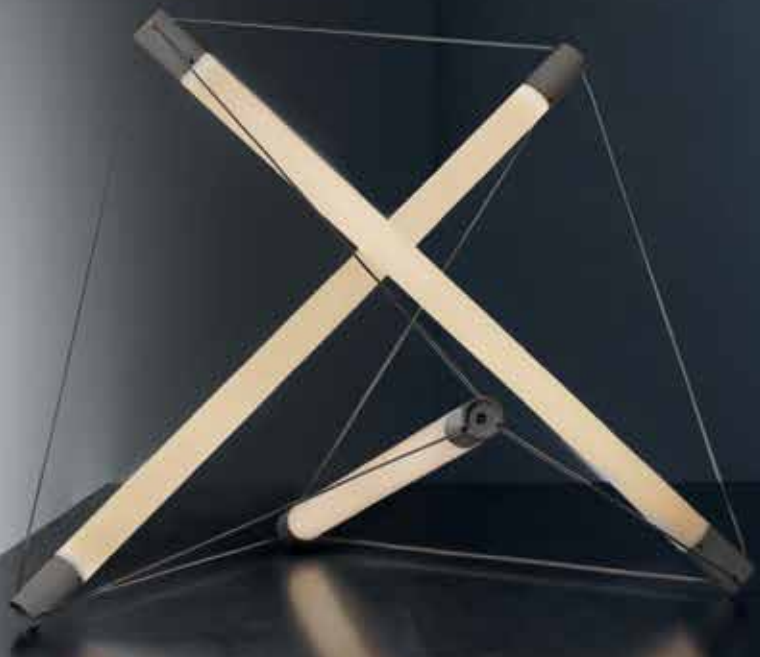

**A stunning combination  
of LED technology  
and the archaic experience of light**







**My New Flame**



40

• 9 •



**My New Flame** Moritz Waldemeyer,  
Ingo Maurer und Team 2013

Platine, Metall, Kunststoff. Basierend auf Video-  
material, geben die zwei LED Displays das leichte  
Flackern einer Flamme realistisch und faszinie-  
rend wieder. Dimmbar. Mit Schalter im Fuß und  
USB-Kabel in Schwarz, 150 cm. Betrieben mit 4  
AA/Mignon NiMH-Akkus, jeweils max. 1,2 Volt  
(nicht im Lieferumfang enthalten) oder über das  
USB-Kabel. ■ Circuit board, metal, plastic. Based  
on video material, the two LED displays render  
a flickering candle flame in a realistic and capti-  
vating way. Dimmable. On/Off switch in base  
plate. With black USB cable, 150 cm. Powered  
by 4 AA/Mignon NiMH rechargeable batteries,  
max. 1.2 V each (not included) or via the USB  
cable. ■ Platine, métal, plastique. Les deux écrans  
LED programmés sur la base d'un clip video,  
rendent le léger vacillement d'une flamme réaliste  
et fascinant. Dimmable. Interrupteur sur le pied.  
Avec câble USB noir, longueur 150 cm. Fonctionne  
avec 4 piles AA/Mignon NiMH rechargeables,  
de chacune maximal 1,2 volts (piles non four-  
nies). ■ Circuito stampato, metallo, materiale  
sintetico. Programmati in base a un filmato, i  
schermi LED riproducono in modo realistico e  
affascinante l'effetto fiamma di una vera candela.  
Dimmerabile. Interruttore nella base. Con cavo  
USB in nero, lunghezza 150 cm. Funzionamento  
con 4 accumulatori AA/Mignon NiMH, max. 1,2  
volt ciascuno (non compresi nella fornitura).



**Now with  
USB cable!**





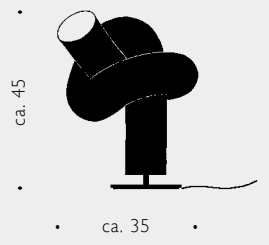

### **Knot** Ingo Maurer 2013

Limitierte Produktion. Polyamid, Aluminium. Der Knoten wird in einem 3D-Druckverfahren einzeln hergestellt. Knot 1 und 3 haben einen Fuß aus Stahl. ■ Limited production. Polyamide, aluminium. Made in three-dimensional printing technology. Knot 1 and 3 have a lamp base made of steel. ■ Production limitée. Polyamide, aluminium. Chaque Knot est conçu individuellement grâce au procédé d'imprimerie 3D. Knot 1 et 3 ont une base de lampe en acier. ■ Produzione limitata. Poliamide, alluminio. Ogni nodo viene prodotto singolarmente con un procedimento di stampa 3D. Knot 1 e 3 hanno una base di acciaio.

 14,6 W LED, 1800 lm, 3000 K, EEC A  230/125/36 V

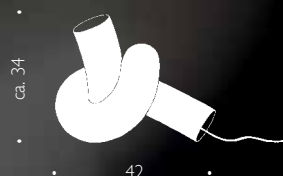

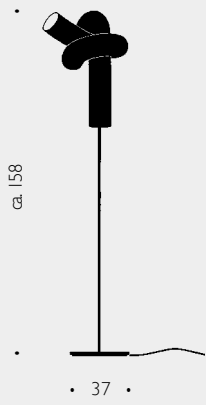

**Knot 3**









**Oskar** Ingo Maurer 1998

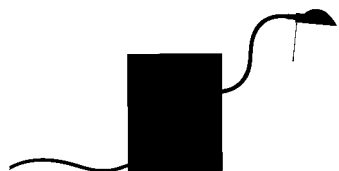



**Kuddelmuddel** Tobias Reischle 2008

Metall, Kunststoff. Lampenfuß mit Kippschalter. Länge des flexiblen Arms 70 cm. Lieferung mit Leuchtmittel. ■ Metal, plastic. Base with toggle switch. Length of flexible arm 70 cm. Complete with bulb. ■ Métal, matière plastique. Pied avec interrupteur à bascule. Longueur du bras flexible 70 cm. Livrée avec ampoule. ■ Metallo, materiale sintetico. Base con interruttore a levetta. Lunghezza del braccio flessibile 70 cm. Lampadina inclusa.

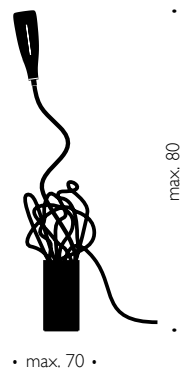

**Zak Zarak** Lutz Pankow, Ingo Maurer 2012

Aluminiumkomposit in Schwarz oder Silber; Metall, Kunststoff. Magnete ersetzen die Federn und Haken herkömmlicher Tischlampen. Im Metallfuß um 360° drehbar. Leuchtenkopf um 30° schwenkbar. Mit Vorschaltgerät und eingebauter LED. ■ Aluminium composite in black or silver, metal, plastic. Magnets replace the springs and hooks of standard desk lamps. Rotates at the base 360°. Lamp head swivels through 30°. With electronic ballast and built-in LED. ■ Aluminium composite en noir ou argent, métal, matière plastique. Des aimants remplacent les ressorts et crochets des lampes de bureaux traditionnelles. Rotatif à 360° au niveau de la base. Tête pivotante à 30°. Avec ballast électronique et LEDs intégrés. ■ Alluminio composito in nero o argento, metallo, materiale sintetico. Calamite sostituiscono le molle e i ganci normalmente impiegati nelle lampade da tavolo convenzionali. Rotante di 360° nel piede in metallo. Testina basculante di 30°. Con alimentatore elettronico. Munito di LED integrate.





max. 85

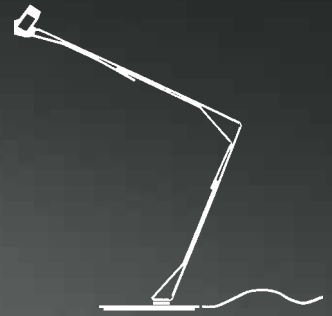

20,5

max. 80



**Looksoflat** *Stefan Geisbauer 2010*

Aluminium. Schalter am Leuchtenkopf. Erhältlich in Aluminium natur oder Schwarz. Mit Steckernetzteil. Lieferung mit Leuchtmittel. ■ Aluminium. Toggle switch integrated in lamp head. Colour aluminium or black. Plug with integrated power supply. Complete with bulb. ■ Aluminium. Interrupteur à bascule intégré à la tête de la lampe. Couleur aluminium ou noir. Avec ballast électronique. Livrée avec ampoule. ■ Alluminio. Interruttore integrato nella testa della lampada. Colore alluminio o nero. Con alimentatore. Lampadina inclusa.



44 - 70

23







### **Bulb** *Ingo Maurer 1966*

Hochglanzverchromtes Metall, mundgeblasenes Kristallglas. Lieferung mit kuppenverspiegelter Glühlampe. ■ Polished chromium-plated metal base, hand-blown crystal glass. Complete with top-chromated bulb. ■ Métal chromée, cristal soufflé. Livrée avec ampoule à coupole argentée. ■ Metallo cromato lucido, cristallo soffiato. Lampadina a cupola argentata inclusa.

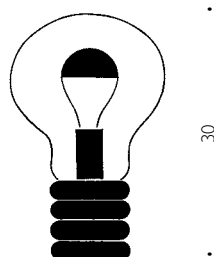

 100 W, top-chromated, EEC  E 27, max. 100 W, A++-E

• 20 •

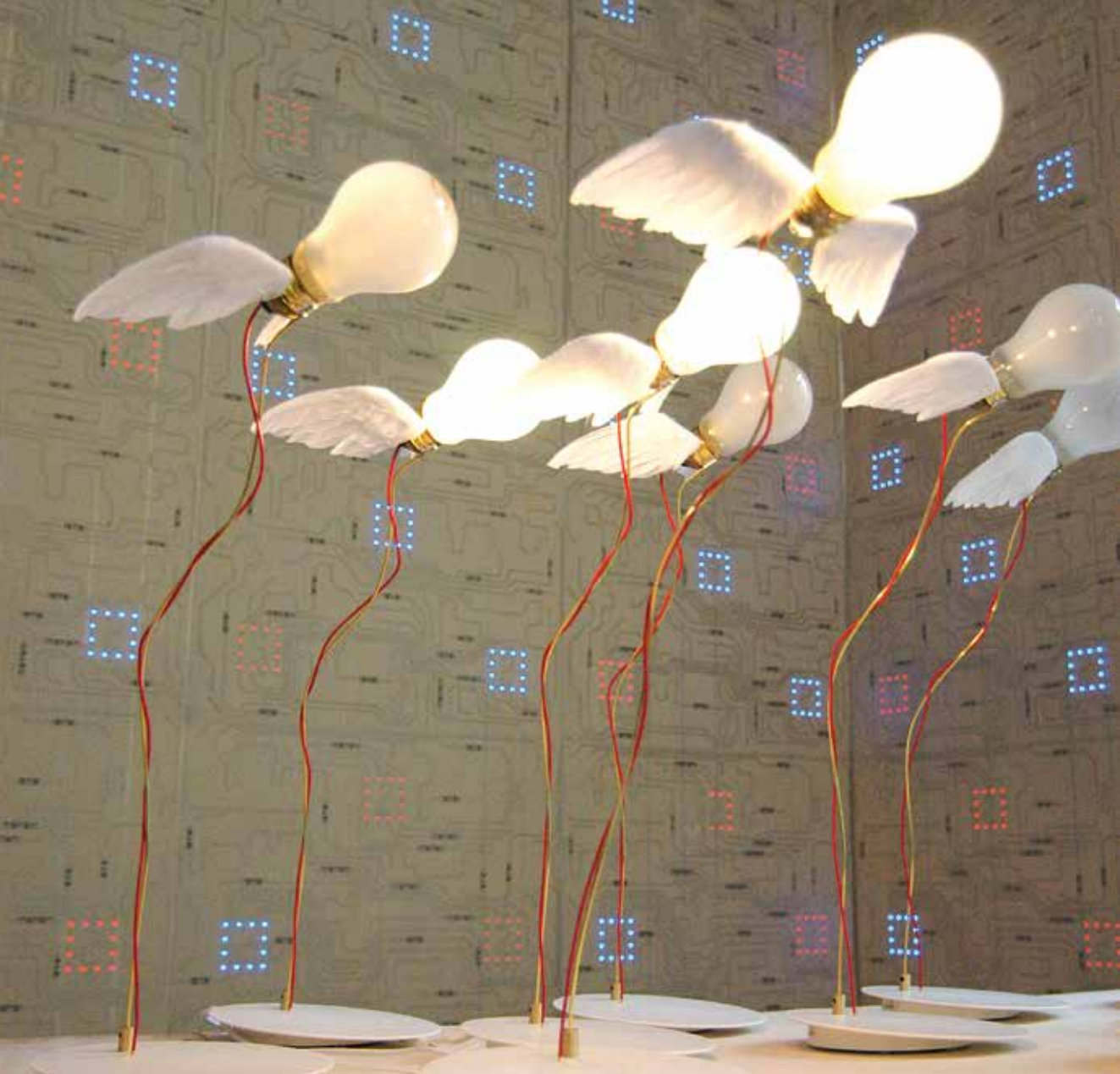

At some point, someone decided that the frosted light bulb was our enemy, inefficient, and a hazard to the environment, so they lobbied to banish its beauty into extinction.

Disgusted with the alternatives we created a new efficient bulb technology – an innovative 24 V halogen which thumbs its nose at the new legislation. Greener than its predecessor, it possesses the same frosty white light we have known and loved, and it is coming to a reality near you, sooner than you think. In fact it's already shipping. Be happy, the future is warm, bright, and friendlier than ever. You can thank us later.

Ingo Maurer und Team 2009

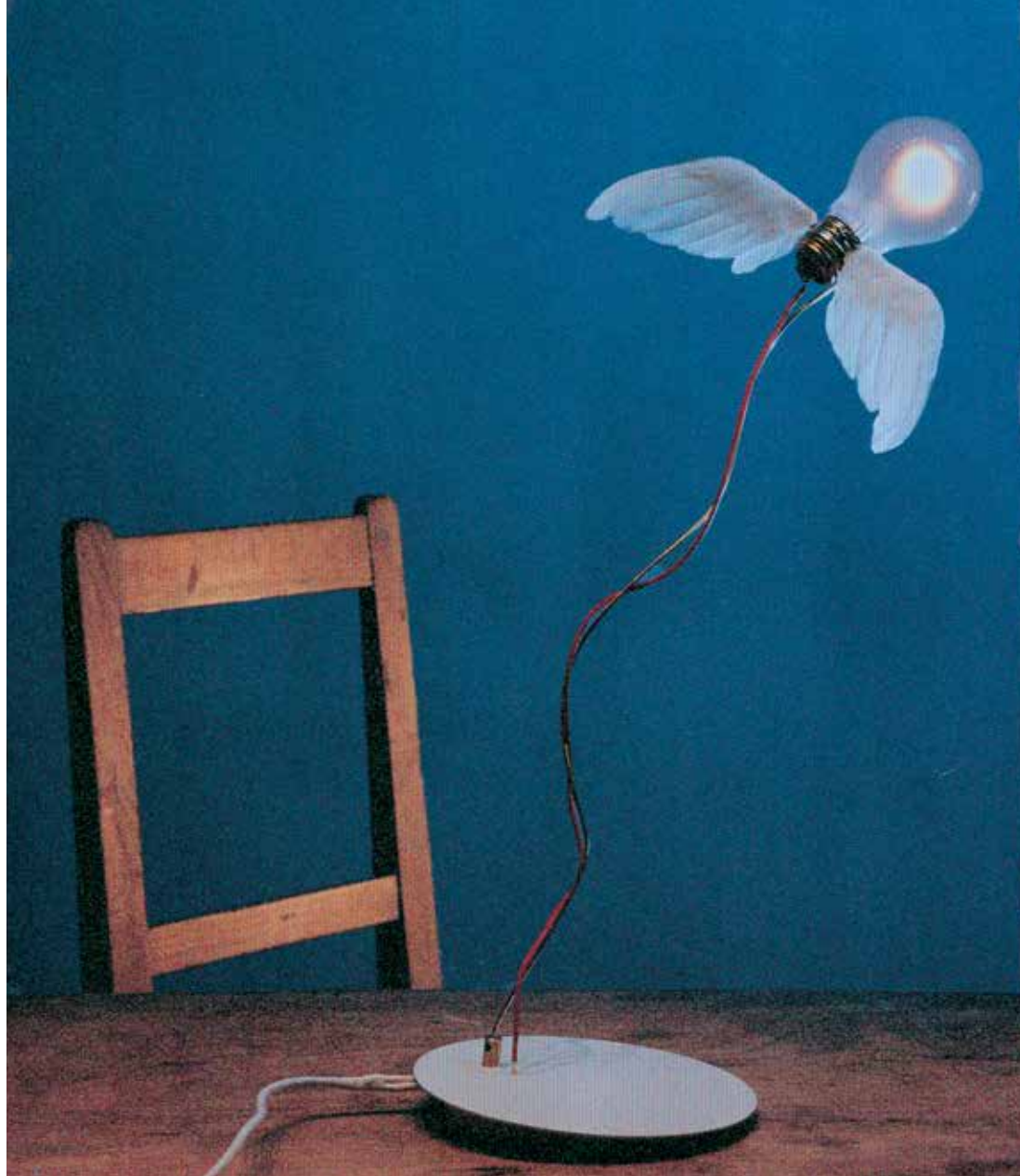

**Lucellino Ingo Maurer 1992**

Glas, Messing, Kunststoff, handgefertigte Flügel aus Gänsefedern. Lieferung mit Ersatzglühlampe. Nicht geeignet für Räume mit hoher Luftfeuchtigkeit. ■ Glass, brass, plastic, hand-crafted goosefeather wings. Complete with spare bulb. Not suited for rooms with high humidity. ■ Verre, laiton, matière plastique, ailes confectionnées à la main en plumes d'oie. Livrée avec une ampoule de rechange. N'est pas appropriée pour des pièces avec un fort taux humidité. ■ Vetro, ottone, materiale sintetico, ali in piume d'oca lavorate a mano. Fornita con lampadina di ricambio. Non adatta all'uso in ambienti ad alta umidità.

24V Halogen EU approved

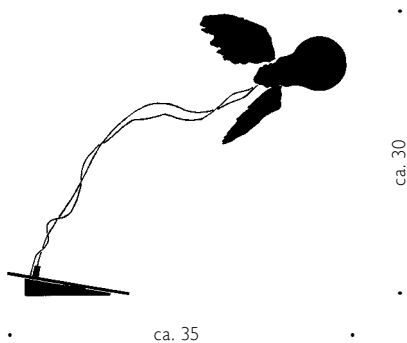

ca. 30

ca. 35

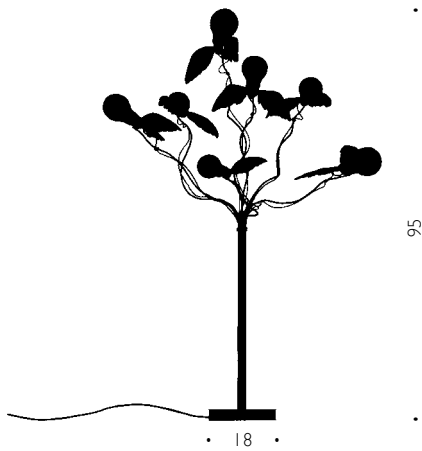

### **Birdie's Busch** *Ingo Maurer und Team 2010*

Metall, Flügel aus Gänsefedern. Sieben Niedervolt-Glühlampen, transparente Kabel. Kabel mit Schalter; nicht dimmbar. Transformator im Lampenfuß integriert. Lieferung mit zwei Ersatzglühlampen. ■ Metal, goose-feather wings. Seven low-voltage bulbs, transparent cables. Cable with switch, not dimmable. Transformer integrated into base. Complete with bulbs plus two spares. ■ Métal, ailes en plumes d'oie, sept ampoules à bas voltage, câbles transparents. Câble avec interrupteur; non dimmable. Transformateur intégré dans le pied. Livrée avec deux ampoules de rechange. ■ Metallo, ali in piume d'oca, sette lampadine a basso voltaggio, cavi trasparenti. Cavo con interruttore, non dimmerabile. Trasformatore integrato nella base. Include due lampadine di ricambio.

**24V Halogen EU approved**





**Alizz T. Cooper** Ingo Maurer und Team 2008

Metall, Kunststoff, flexibler Gummischlauch. Kabel mit Schalter. Reflektor 360° um das Leuchtmittel drehbar. Lieferung mit Leuchtmittel. ■ Metal, plastic, flexible rubber hose. Cable with switch. Reflector rotates through 360° around the bulb. Complete with bulb. ■ Métal, matière plastique, tuyau en caoutchouc flexible. Câble avec interrupteur. Réflecteur rotatif de 360° autour de l'ampoule. Livrée avec ampoule. ■ Metallo, materiale sintetico, tubo di gomma flessibile. Cavo con interruttore. Riflettore rotante di 360° intorno alla lampadina. Lampadina inclusa.

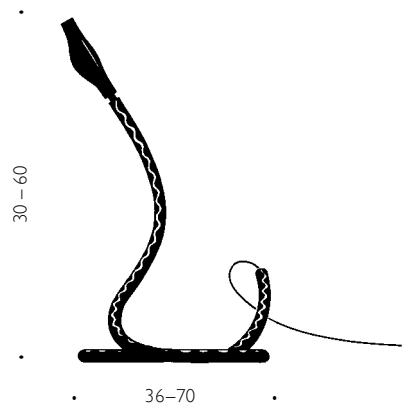



**Metall T. Cooper** *Ingo Maurer und Team 2009*

Metall, Kunststoff, Kabel mit Schalter. Reflektor 360° um das Leuchtmittel drehbar. Lieferung mit Leuchtmittel. ■ Metal, plastic, cable with switch. Reflector rotates through 360° around the bulb. Complete with bulb. ■ Métal, matière plastique, câble avec interrupteur. Réflecteur rotatif de 360° autour de l'ampoule. Livrée avec ampoule. ■ Metallo, materiale sintetico, cavo con interruttore. Riflettore rotante di 360° intorno alla lampadina. Lampadina inclusa.

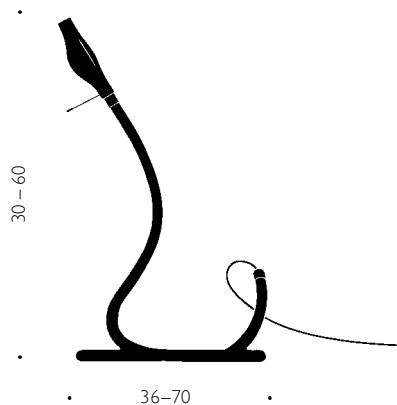

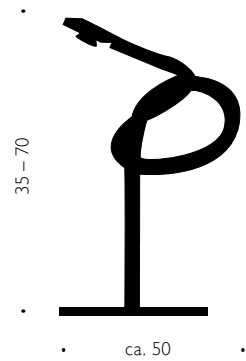

35 - 70

ca. 50





**Zufall** Ingo Maurer und Team 2008

Silikon, schwarzes Corian, Aluminium. Der Silikonarm kann flexibel geformt werden. Eingebauter Kippschalter im Lampenfuss. Mit Steckertransformator. ■ Silicone, black Corian, aluminium. The silicone arm can be formed flexibly. Base plate with integrated toggle switch. With transformer. ■ Silicone, Corian noir, aluminium. La forme du tuyau flexible en silicone peut être modifiée. Plaque de base avec interrupteur à bascule intégré. Livrée avec transformateur. ■ Silicone, Corian nero, alluminio. Il braccio in silicone flessibile può essere modellato a piacere. Piastra di base con interruttore a levetta. Con trasformatore.



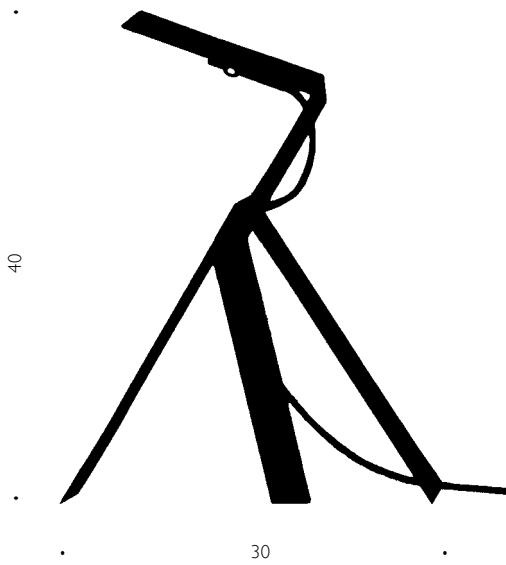

**Jetzt Axel Schmid 2009/2015**

Eloxiertes Aluminium in Schwarz, Blau oder Silber, Kunststoff. Mit Sensorschalter zum Anschalten und stufenlosen Dimmen. ■ Anodized aluminium in black, blue or silver, plastic. With dimmable touch sensor switch. ■ Aluminium anodisé disponible en noir, bleu ou argent, matière plastique. Avec interrupteur à sensor tactile pour allumer et faire varier l'intensité de la lumière. ■ Alluminio anodizzato in nero, blu o argento, materiale sintetico. Interruttore a sensore per accendere, spegnere e dimmerare

**Now bigger and brighter, better light!**

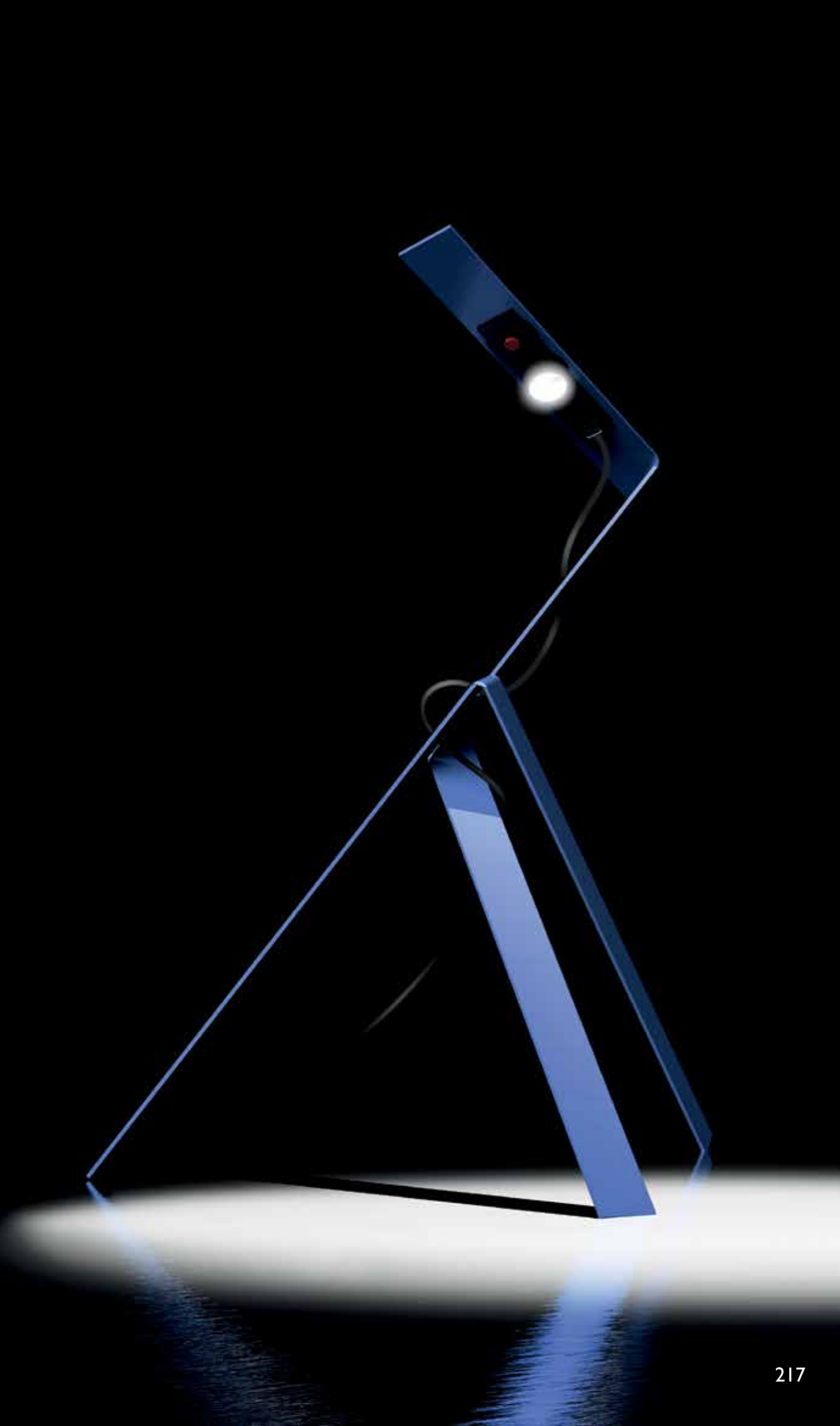



**Max. Kugler Ingo Maurer und Team 2001/2015**

Edelstahl, Aluminium. Das Kugelgelenk ermöglicht stufenloses Drehen und Neigen in alle Richtungen. Der Teleskoparm ist von 60 auf 90 cm ausziehbar. An seinem Griff ist der Reflektor in alle Richtungen schwenkbar. Auch mit schwarzen Reflektor erhältlich. Dimmer mit Schieberegler. Lieferung mit Leuchtmittel. ■ Stainless steel, aluminium. The ball-joint makes it possible to turn and tilt the lamp in all directions. The telescope arm extends from 60 to 90 cm. The reflector (with handle) can be swivelled in any direction. Also available with reflector in black. Dimmer with slide control. Complete with bulb. ■ Acier inoxydable, aluminium. L'articulation à rotule permet de tourner et d'incliner la lampe sans graduation dans tous les sens. Le bras télescopique est extensible de 60 à 90 cm. Le réflecteur est orientable dans tous les sens grâce à sa poignée. Aussi disponible avec réflecteur en noir. Avec variateur à curseur. Livrée avec ampoule. ■ Acciaio inossidabile, alluminio. Ruotabile e inclinabile in continuo in tutte le direzioni mediante un giunto sferico. Il braccio telescopico è allungabile da 60 a 90 cm. Agendo sulla leva, il riflettore può essere regolato in tutte le direzioni. Anche disponibile con riflettore in nero. Con varialuce lineare. Lampadina inclusa.





**Floor version now available, see page 244.**

### **Mozzito** Ingo Maurer und Team 1996

Metall, Kunststoff und Gummi. Mit Kaltlichtspiegellampe. Die Neigung der Lampe kann durch die bewegliche Bodenplatte verändert werden. Reflektor verstellbar. Lieferung mit Leuchtmittel. ■ Metal, plastic and rubber. With cool beam bulb. Position can be modified with movable base-plate. Adjustable reflector. Complete with bulb. ■ Métal, matière plastique et caoutchouc. Avec ampoule à miroir dichroïque. La plaque de base mobile permet de varier l'inclinaison de la lampe. Réflecteur réglable. Livrée avec ampoule. ■ Metallo, materiale sintetico e gomma. Con lampadina dicroica. La piastra di base mobile consente di variare l'inclinazione della lampada. Riflettore regolabile. Lampadina inclusa.

 50 W 60° Halogen, 4000 h, EEC B  GX 5,3, max. 50 W, A++-E  230/125/12 V



max 80

80



### **Campari Bar** *Raffaele Celentano 2013*

Zehn originale Campari-Soda-Flaschen, einzeln abnehmbar, Kunststoff, Metall, Glas. Über den zehn Campari-Soda-Flaschen liegen Eiswürfel aus Glas, die das Licht brechen und reflektieren. Zugschalter an der Fassung. Lieferung mit Leuchtmittel. ■ Ten original Campari Soda bottles, individually detachable. Plastic, metal, glass. Above the ten Campari Soda bottles, ice cubes made of glass reflect the light. With pull switch. Complete with bulb. ■ Dix bouteilles originales de Campari Soda, détachables individuellement. Matière plastique, métal, verre. Au-dessus des dix bouteilles de Campari Soda sont posés des glaçons en verre, qui font refléter la lumière. Interrupteur au niveau de la douille. Livrée avec ampoule. ■ Dieci bottiglie originali di Campari Soda, singolarmente staccabili. Materiale sintetico, metallo, vetro. Cubetti di ghiaccio in vetro posizionati sopra le bottiglie di Campari Soda, riflettono la luce. Portalampana con interruttore a tirante. Lampadina inclusa.









**Limited  
edition.  
Each is  
unique in  
its shape  
and expression.**



**HOT.HOT** Ingo Maurer und Team 2006

Metall, Glas, schwarz lackierter Stahl. Der Lichtkegel kann durch ein Linsensystem eingestellt werden. Limitierte Edition in Messing erhältlich. Lieferung mit Leuchtmittel. ■ Metal, glass, black lacquered steel. The cone of light is adjustable by a lens system. Limited edition in brass available. Complete with bulb. ■ Métal, verre, acier noir laqué. Le cône lumineux peut être ajusté à l'aide d'un système de lentilles. Edition limitée en laiton disponible. Livrée avec ampoule. ■ Metallo, vetro, acciaio verniciato nero. Il cono di luce può essere regolato mediante un sistema di lenti. Disponibile anche l'edizione limitata in ottone. Lampadina inclusa.

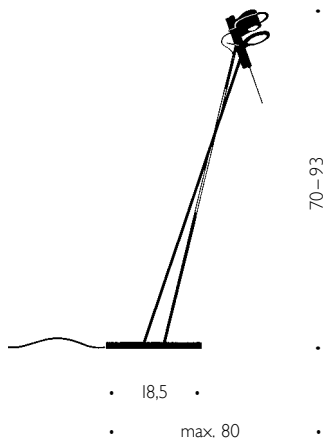



**DeliriumYum** Ingo Maurer/Sebastian Hepting 2006

Corian, Kristallglas, Spiegel aus Aluminium. Externer Transformator. Interner Motor. Licht und Bewegung des Wassers regulierbar. Tempo und Intervalle der Drehung werden elektronisch gesteuert und können angepasst werden. Mit Kugel, Silberpartikeln, Tabletten zur Wasseraufbereitung und Leuchtmittel. ■ Corian, crystal glass, aluminium mirror. External transformer. Internal motor. Light and movement of water adjustable. Speed and intervals of the rotation are electronically adjustable. Complete with ball, silver particles, tablets for water preparation, and bulb. ■ Corian, cristal, miroir en aluminium. Transformateur externe. Moteur interne. Lumière et mouvement d'eau réglables. Le rythme et l'intervalle de la rotation peuvent être réglés et changés électroniquement. Livrée avec balle, particules d'argent, pastilles pour préparation de l'eau et ampoule. ■ Corian, cristallo, specchio in alluminio. Trasformatore esterno. Motore interno. Intensità della luce e movimento dell'acqua regolabili. La velocità e gli intervalli del movimento rotatorio sono a comando elettronico e possono essere adattati. Con sfera, polverina d'argento, pasticche per la preparazione dell'acqua e lampadina.



### **Lampampe** *Ingo Maurer 1980*

Japanisches Papier; Metall. Als gewolltes gestalterisches Element ist das Papier von Lampampe verknittert. Nicht geeignet für Räume mit hoher Luftfeuchtigkeit. Lieferung ohne Glühlampe. ■ Japanese paper, metal. The paper of Lampampe is crinkled. This is an intended design attribute. Not suited for rooms with high humidity. Bulb not included. ■ Papier japonais, métal. Le papier pour Lampampe est froissé, ainsi voulu comme effet de style. N'est pas appropriée pour des pièces avec un fort taux humidité. Livrée sans ampoule. ■ Carta giapponese, metallo. Una caratteristica voluta del design di Lampampe è l'effetto sgualcito della carta. Non adatta all'uso in ambienti ad alta umidità. Lampadina non inclusa.

 E27, max. 100 W, A++-E

Recommended retrofit LED bulb for 230 volts available through Ingo Maurer.

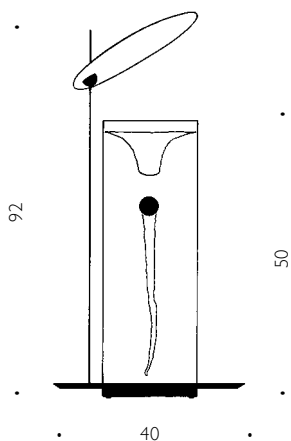

**DeliriumYum**

max. 35 W Halogen GU4 12V

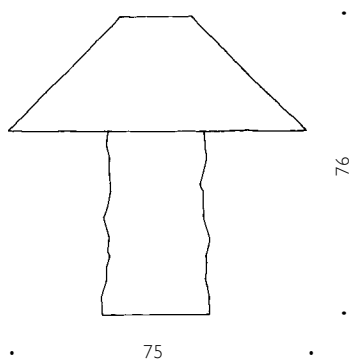

**Lampampe**

max. 100 W E27

Projects are always a challenge – they give space for the realisation of visions and release new energies which are necessary to accomplish the job.

Our work – both large scale and small scale – ranges from public spaces, landmark buildings to individually commissioned one-of-a-kind creations. Some experimental objects are created purely because it's so tempting to work with new materials.

We are always ready to inform you. Please contact us for further information.  
[info@ingo-maurer.com](mailto:info@ingo-maurer.com)







**Bibibibi** Ingo Maurer 1982

Porzellan, Metall und Plastik. Beweglicher Reflektor. Lieferung mit Glühlampe. ■ Porcelain, metal, plastic. Adjustable reflector. Complete with bulb. ■ Porcelaine, métal et matière plastique. Réflecteur réglable. Livrée avec ampoule. ■ Porcellana, metallo e materiale sintetico. Riflettore orientabile. Lampadina inclusa.

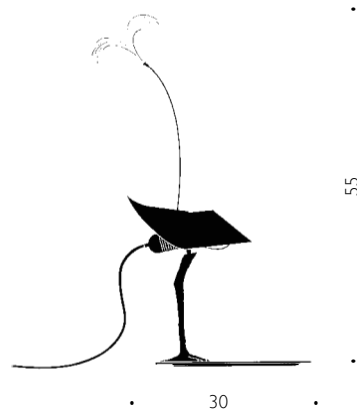



**Don Quixote** Ingo Maurer und Team 1989

Stahl, Aluminium, elastischer Kunststoff. Don Quixote biegt und schwenkt sich, dreht und streckt sich. Lieferung mit Leuchtmittel. ■ Steel, aluminium, flexible plastic. Don Quixote bends, twists, turns and swivels. Complete with bulb. ■ Acier, aluminium, matière plastique élastique. Don Quixote s'incline et pivote, se tourne et s'étire. Livrée avec ampoule. ■ Acciaio, alluminio, materiale sintetico elastico. Don Quixote s'inclina e si gira, ruota e si stende. Lampadina inclusa.

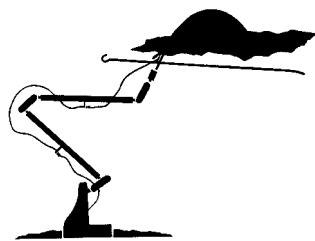

• ca. 35 •



**24 Karat Blau T** Axel Schmid 2005

Metall, in Kunststoff eingegossenes Blattgold. Die vier goldenen Blenden können am Stabkreuz in verschiedenen Winkeln und Positionen aufgehängt werden. Lieferung mit Leuchtmittel. ■ Metal, gold leaf sealed in plastic. The four golden shades can be hung in various angles and positions. Complete with bulb. ■ Métal, matière plastique, feuille d'or. Les quatres écrans peuvent être suspendus dans différents angles et positions. Livrée avec ampoule. ■ Metallo, foglio d'oro laminato con materiale sintetico. I quattro paralumi d'oro possono essere appesi sull'asta a croce in vari angoli e posizioni. Lampadina inclusa.

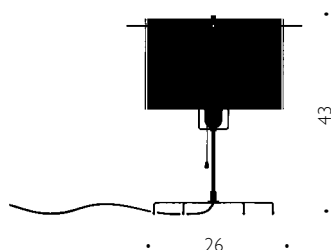



**Seven Rats** Ingo Maurer und Team 2007

Stahl, Gold, Messing, Kunststoff. Vier schwarze und drei weiße Kunststoffratten. Lieferung mit Leuchtmittel. ■ Steel, gold, brass, plastic. Four black and three white plastic rats. Complete with bulb. ■ Acier, or, laiton, matière plastique. Quatre rats noirs et trois rats blancs en matière plastique. Livrée avec ampoule. ■ Acciaio, oro, ottone, materiale sintetico. Quattro topi neri e tre topi bianchi di materiale sintetico. Lampadina inclusa.

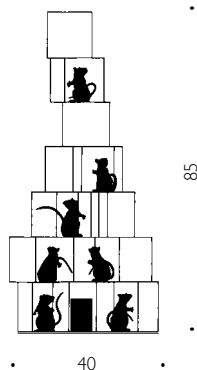



### **Grasl Jan Roth 1973**

Reflektor aus glanzeloxiertem Aluminium und Messing. Kabel mit Schalter und Stecker. Lieferung mit Glühlampe. Auch als Hängelampe. ■ Reflector: anodized aluminium, brass. Cable with switch and plug. Complete with bulb. Also available as hanging lamp. ■ Réflecteur en aluminium électrolysé et laiton. Câble avec interrupteur et prise de courant. Livrée avec ampoule. Egalement disponible comme suspension. ■ Riflettore in alluminio anodizzato e ottone. Cavo con interruttore e spina. Lampadina inclusa. Disponibile anche nella versione a sospensione.



**One From The Heart** Ingo Maurer 1989

Metall, beweglicher Glas-Spiegel und Kunststoff. Multi Mirror-Reflektor mit Schutzglas.  
 Lieferung mit Leuchtmittel. ■ Metal, plastic, adjustable glass mirror. Multi-Mirror reflector  
 with protective glass cover. Complete with bulb. ■ Métal, miroir mobile en verre et  
 matière plastique. Réflecteur Multi Mirror avec verre protecteur. Livrée avec ampoule. ■  
 Metallo, specchio orientabile in vetro e materiale sintetico. Riflettore Multi Mirror con vetro  
 di protezione. Lampadina inclusa.

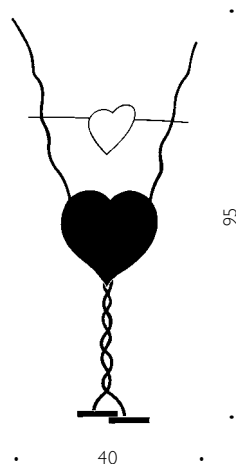

💡 50 W 36° Halogen, 775 lm, 3000 K, 4000 h, EEC B

🔌 GX 5,3, max. 50 W, A++-E 📡 230/125/12 V





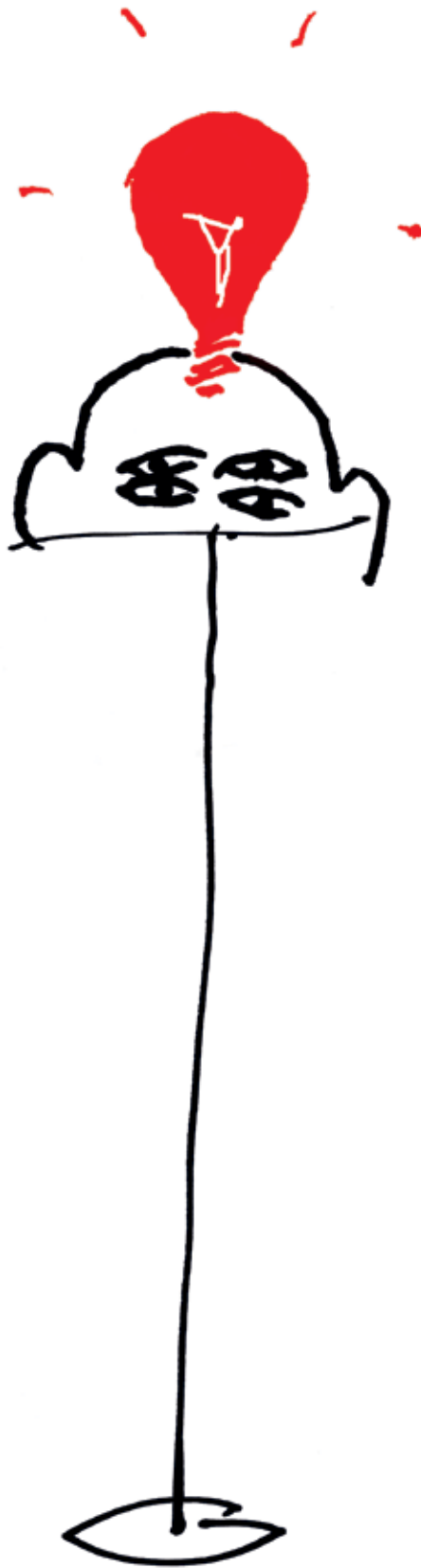

Stehlampen / Floor lamps / Lampadaires / Lampade a stelo

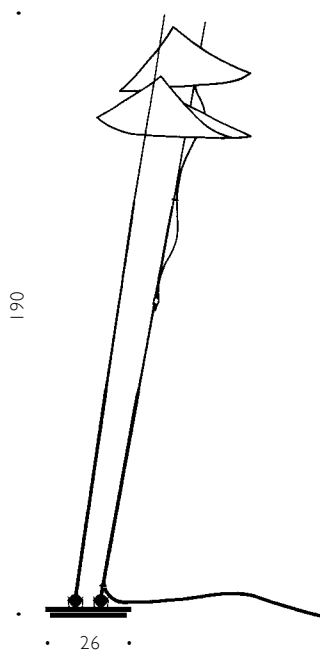

### **Dew Drops Floor** Ingo Maurer Team 2015

Transparente Kunststoffolie mit integrierten LEDs, Metall. Die Stäbe sind mit Kugelgelenken auf der Fußplatte (19×26 cm) montiert. Mit Sensorschalter zum Anschalten und Dimmen auf der Folie. ■ Transparent plastic sheet with integrated LEDs, metal. Two rods, adjustable via ball-joints mounted on the base (19×26 cm). With dimmable touch sensor switch on the sheet. ■ Film plastique transparent avec LEDs intégrés, métal. Les tiges sont montées grâce à une articulation à rotule sur la plaque (19×26 cm). Avec interrupteur à sensor tactile pour allumer et faire varier l'intensité de la lumière sur le film plastique. ■ Pellicola trasparente in materiale sintetico con LED integrati, metallo. Le due aste sono fissate alla base (19×26 cm) tramite giunti a sfera. Interruttore a sensore sulla pellicola stessa per accendere, spegnere e dimmerare.

**With one or two LED sheets, and one paper sheet as additional diffusor. The sheets can be placed as up- or downlight, depending on the light you wish to create.**







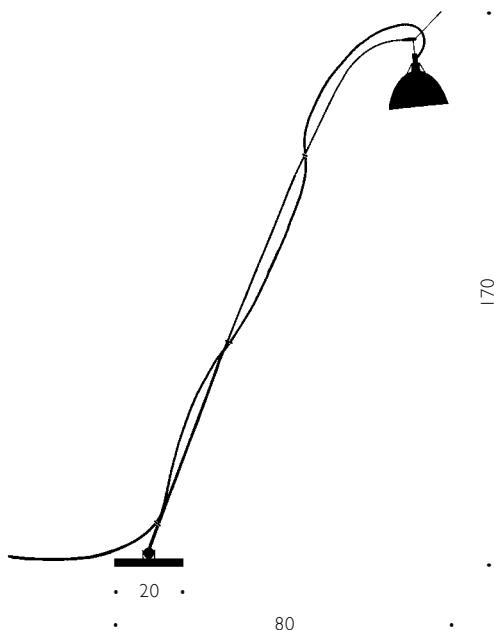

**Max. Floor** Ingo Maurer und Team 2015

Edelstahl, Aluminium. Das Kugelgelenk ermöglicht stufenloses Drehen und Neigen in alle Richtungen. An seinem Griff ist der Reflektor in alle Richtungen schwenkbar. Dimmer mit Schieberegler. Lieferung mit Leuchtmittel. ■ Stainless steel, aluminium. The ball-joint makes it possible to turn and tilt the lamp in all directions. The reflector (with handle) can be swivelled in any direction. Dimmer with slide control. Complete with bulb. ■ Acier inoxydable, aluminium. L'articulation à rotule permet de tourner et d'incliner la lampe sans graduation dans tous les sens. Le réflecteur est orientable dans tous les sens grâce à sa poignée. Avec variateur à curseur. Livrée avec ampoule. ■ Acciaio inossidabile, alluminio. Ruotabile e inclinabile in continuo in tutte le direzioni mediante un giunto sferico. Agendo sulla leva, il riflettore può essere regolato in tutte le direzioni. Con varialuce lineare. Lampadina inclusa.

**An elegant solution, flexible and of timeless beauty.**



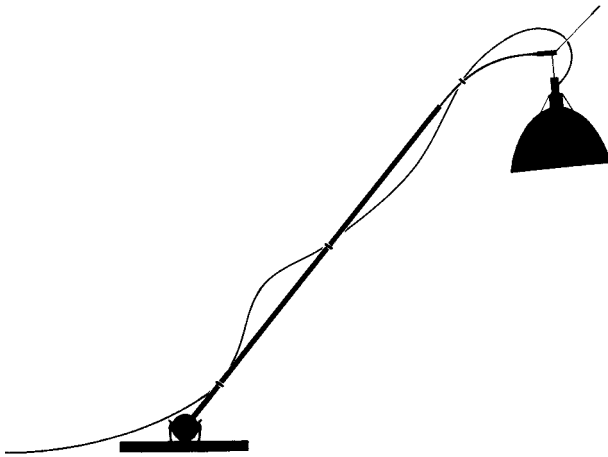
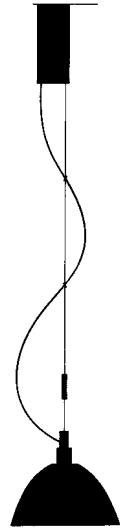
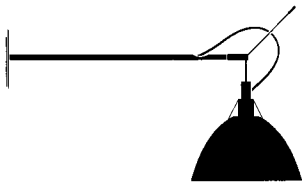

**Max. Kugler, Max. Up & Down and Max. Wall**  
**soon available with LED light sources.**









**Max. Floor** black

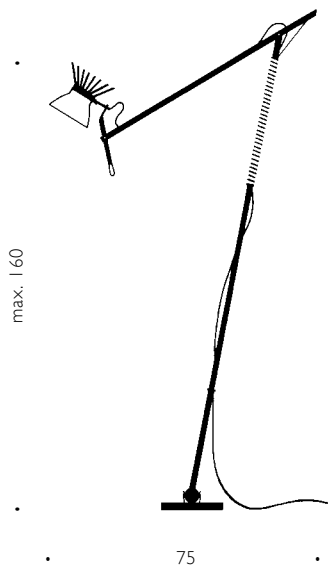

**Bastardo Floor** *Bernhard Dessecker/Ingo Maurer 2015*

Aluminium, Metall, Silikon, Kunststoff. Die Neigung der Lampe lässt sich über das Kugelgelenk am Fuß einstellen. ■ Aluminium, metal, silicone, plastic. The angle of the lamp is adjustable by the ball-and-socket joint in the base. ■ Aluminium, métal, silicone, matière plastique. L'inclinaison de la lampe est réglable par l'articulation à rotule au niveau du socle. ■ Alluminio, metallo, silicone, materiale sintetico. L'inclinazione della lampada può essere regolata mediante un giunto a sfera.

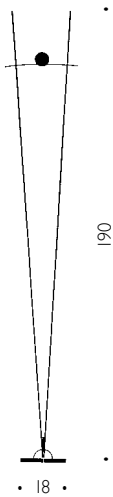







Photo of the moon taken in the desert of Namibia by Markus Tollhopf.



**Ilios** Ingo Maurer, Franz Ringelhan 1983

Silber oder schwarz. Metall und Glas, Isolationskeil fluoreszierend rot. Lieferung mit Leuchtmittel. ■ Choice of silver or black metal, glass, red fluorescent insulator. Complete with bulb. ■ Argent ou noir. Métal et verre, pièce d'isolation rouge fluorescente. Livrée avec ampoule. ■ Argento o nero. Metallo e vetro, elemento isolante rosso fluorescente. Lampadina inclusa.

💡 50 W Halogen, 910 lm, 3000 K, 2000 h, EEC C

🔌 GY 6,35, max. 50 W, B-E ⚡ 230/125/12 V



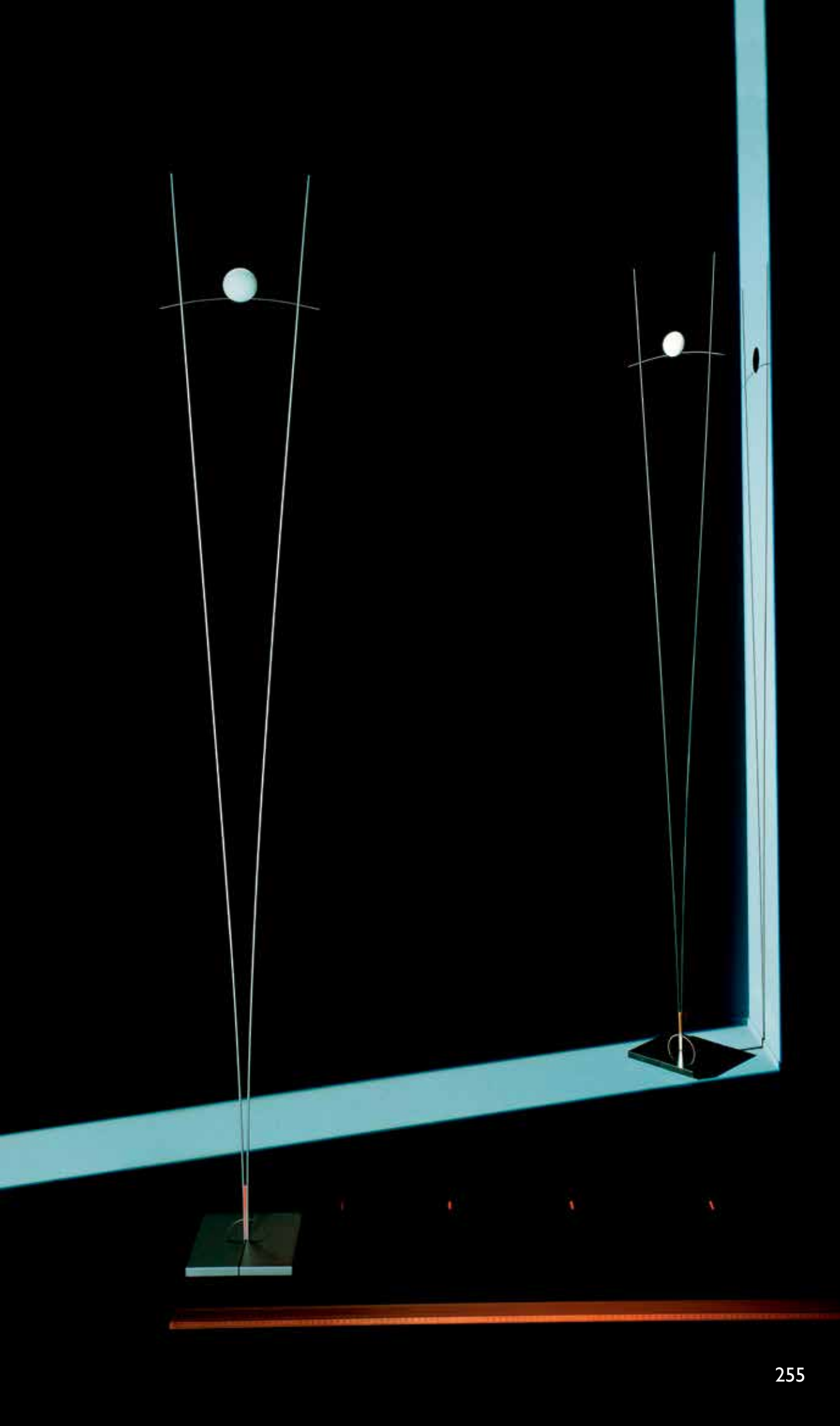



**Metall F. Cooper** *Ingo Maurer und Team 2009*

Metall, Kunststoff. Die obere flexible Hälfte des Stabes ermöglicht die variable Einstellung des Reflektors. Reflektor 360° um das Leuchtmittel drehbar. Stufenlos dimmbar. Lieferung mit Leuchtmittel. ■ Metal, plastic. The upper flexible half of the stem allows variable adjustment. Reflector rotates through 360° around the bulb. Continuously variable dimmer. Complete with bulb. ■ Métal, matière plastique. La moitié supérieure et flexible de la tige permet le réglage variable du réflecteur. Réflecteur rotatif de 360° autour de l'ampoule. Réglage de l'intensité lumineuse sans graduation. Livrée avec ampoule. ■ Metallo, materiale sintetico. La parte superiore dell'asta è flessibile e permette la regolazione variabile del riflettore. Riflettore rotante di 360° intorno alla lampadina. Regolazione continua dell'intensità luminosa. Lampadina inclusa.



**Alizz F. Cooper** *Ingo Maurer und Team 2008*

Metall, Kunststoff, Gummischlauch. Die obere flexible Hälfte des Stabes ermöglicht die variable Einstellung des Reflektors. Reflektor 360° um das Leuchtmittel drehbar. Stufenlos dimmbar. Lieferung mit Leuchtmittel. ■ Metal, plastic, rubber hose. The upper flexible half of the stem allows variable adjustment. Reflector rotates through 360° around the bulb. Continuously variable dimmer. Complete with bulb. ■ Métal, matière plastique, tuyau en caoutchouc. La moitié supérieure et flexible de la tige permet le réglage variable du réflecteur. Réflecteur rotatif de 360° autour de l'ampoule. Réglage de l'intensité lumineuse sans graduation. Livrée avec ampoule. ■ Metallo, materiale sintetico, tubo di gomma. La parte superiore dell'asta è flessibile e permette la regolazione variabile del riflettore. Riflettore rotante di 360° intorno alla lampadina. Regolazione continua dell'intensità luminosa. Lampadina inclusa.





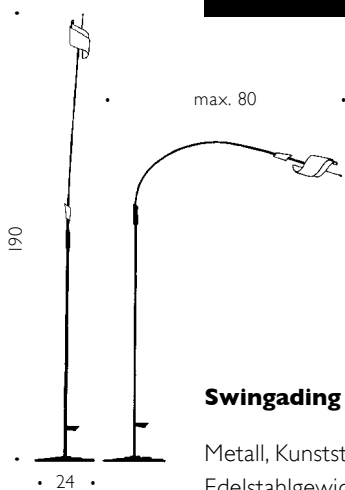

### **Swingading** *Bernhard Dessecker 1993*

Metall, Kunststoff, Glas. Stab flexibel ab 100 cm Höhe durch ein stufenlos bewegliches Edelstahlgewicht. Reflektor mit Schutzglas. Reflektor und Blenden sind um 360° drehbar. Ausführung nur in Schwarz. Lieferung mit Leuchtmitteln. ■ Metal, plastic, glass. The top part of the stem (above 100 cm) is flexible and can be fixed in the required position by moving the stainless-steel weight. Reflector fitted with protective glass cover. Reflector and shades freely rotatable. Only in black. Complete with bulbs. ■ Métal, matière plastique, verre. Tige flexible à partir d'une hauteur de 100 cm par un contre-poids coulissant en acier spécial. Réflecteur avec verre protecteur. Réflecteur et écran sont orientables sur 360°. Seulement en noir. Livrée avec ampoules. ■ Metallo, materiale sintetico. Asta flessibile a partire da 100 cm d'altezza mediante un peso scorrevole in acciaio inossidabile. Riflettore con vetro di protezione. Il riflettore e gli schermi ruotano di 360°. Solamente in nero. Lampadine incluse.

💡 230 V: 50 W + 5 W Halogen, 125 V: 35 W + 5 W Halogen, 910 lm, 3000 K, 2000 h, EEC C

🔌 GY 6,35, max. 50 W + G4, max. 5 W, 125 V: max. 35 W + 5 W, B-E 🗂️ 230/125/12 V







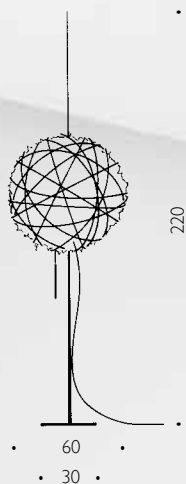

**Knüller** *Bernhard Dessecker 2004*

Glasfaser, Metall, Kunststoff, Seidenpapier. Integriertes elektronisches Tandem-Vorschaltgerät. Zugschalter fluoreszierend. Lieferung mit Leuchtmitteln. ■ Fibre-glass, metal, plastic, tissue paper. Integrated electronic tandem ballast. Fluorescent pull switch. Complete with bulbs. ■ Fibre de verre, métal, matière plastique, papier de soie. Ballast tandem électronique intégré. Tirette fluorescente. Livrée avec ampoules. ■ Vetroresina, metallo, materiale sintetico, carta seta. Alimentatore elettronico bilampada integrato. Interruttore a catenella fluorescente. Lampadine incluse.

### Stand Up ForYour Light Bernhard Dessecker 1998

Edelstahl, Aluminium, Kunststoff. Fuß und Fassung aus transparentem Glas. 230 Volt: Stufenlos dimmbar durch Sensorschalter. 125 Volt: Stufenlos dimmbar mit Schieberegler. Dimmer und Kabel transparent. Lieferung mit Leuchtmittel. ■ Stainless steel, aluminium, plastic, base and socket in transparent glass. 230 volts: Continuously variable dimmer with sensor switch. 125 volts: Continuously variable with slide control. Dimmer and cable transparent. Complete with bulb. ■ Acier inoxydable, aluminium, matière plastique. Socle et douille en verre transparent. 230 volts: Réglage de l'intensité lumineuse sans graduation par interrupteur-senseur. 125 volts: Réglage de l'intensité lumineuse sans graduation par curseur. Gradateur et câble transparents. Livrée avec ampoule ■ Acciaio inossidabile, alluminio, materiale sintetico. Base e portalampada in vetro trasparente. 230 volt: Regolazione continua dell'intensità luminosa mediante interruttore a sensore. 125 Volt: regolazione continua dell'intensità luminosa mediante varialuce lineare. Varia-luce e cavo trasparenti. Lampadina inclusa.





190





Deckenlampen / Ceiling lamps / Plafonniers / Lampade da soffitto



• ca. 50 •

• min. 50, max. 95 •



### **Birdie's Nest** Ingo Maurer 2005

Metall, Flügel aus Gänsefedern, zehn Niedervolt-Glühlampen, transparente Kabel. Lieferung mit 2 Ersatzglühlampen. Birdie's Nest ist für Räume mit geringen Deckenhöhen konzipiert. Nicht geeignet für Räume mit hoher Luftfeuchtigkeit. ■ Metal, goose-feather wings, ten low-voltage bulbs, transparent cables. Complete with bulbs plus 2 spares. Birdie's Nest is designed for rooms with lower ceilings. Not suited for rooms with high humidity. ■ Métal, ailes en plumes d'oie, dix ampoules à bas voltage, câbles transparents. Livrée avec 2 ampoules de rechange. Birdie's Nest est conçu pour des pièces à plafond bas. N'est pas appropriée pour des pièces avec un fort taux humidité. ■ Metallo, ali in piume d'oca, dieci lampadine a basso voltaggio, cavi trasparenti. Include 2 lampadine di ricambio. Birdie's Nest è concepita per soffitti bassi. Non adatta all'uso in ambienti ad alta umidità.

**24V Halogen EU approved**





Made to be co-designed by you.

Enjoy the ability to style it anyway you wish.



### **Luxury Pure Ingo Maurer und Team 2004**

Gold lackiertes Papier, Aluminium. Aufhängung an Seilen aus Polyestergeflecht. Für Raumhöhen ab 270 cm. Lieferung mit Leuchtmittel. Segel 1: 180 x 180 cm. Segel 2: 130 x 130 cm. Segel 3: 90 x 90 cm. Abstand der Deckenhalterung: 270 x 270 cm. ■ Gold lacquered paper, aluminium. For ceiling heights of 270 cm and more. Suspension with braided polyester strings. Complete with bulb. Sail 1: 180 x 180 cm. Sail 2: 130 x 130 cm. Sail 3: 90 x 90 cm. Spacing of ceiling fixtures : 270 x 270 cm. ■ Papier laqué or, aluminium. Pour hauteurs de pièces à partir de 270 cm. Suspension par fils en polyester tressé. Livrée avec ampoule. Voile 1: 180 x 180 cm. Voile 2: 130 x 130 cm. Voile 3: 90 x 90 cm. Distance des suspensions: 270 x 270 cm. ■ Carta verniciata oro, alluminio. Sospensione con fili in poliestere intrecciato. Per soffitti con altezza a partire da 270 cm. Lampadina inclusa. Vela 1: 180 x 180 cm. Vela 2: 130 x 130 cm. Vela 3: 90 x 90 cm. Distanza delle sospensioni: 270 x 270 cm.





**Lil Luxury** Ingo Maurer und Team 2009

Gold, silbern oder weiß lackiertes Papier, Aluminium. Aufhängung an Seilen aus Polyestergeflecht. Für Raumhöhen ab 240 cm. Lieferung mit Leuchtmittel. Segel 1: 120 x 120 cm. Segel 2: 89 x 89 cm. Segel 3: 65 x 65 cm. Abstand der Deckenhalterung: 200 x 200 cm. ■ Gold, silver or white lacquered paper, aluminium. For ceiling heights of 240 cm and more. Suspension with braided polyester strings. Complete with bulb. Sail 1: 120 x 120 cm. Sail 2: 89 x 89 cm. Sail 3: 65 x 65 cm. Spacing of ceiling fixtures: 200 x 200 cm. ■ Papier laqué or, argent ou blanc, aluminium. Pour hauteurs de pièces à partir de 240 cm. Suspension par fils en polyester tressé. Livrée avec ampoule. Voile 1: 120 x 120 cm. Voile 2: 89 x 89 cm. Voile 3: 65 x 65 cm. Distance des suspensions: 200 x 200 cm. ■ Carta verniciata oro, argento o bianco, alluminio. Sospensione con fili in poliestere intrecciato. Per soffitti con altezza a partire da 240 cm. Lampadina inclusa. Vela 1: 120 x 120 cm. Vela 2: 89 x 89 cm. Vela 3: 65 x 65 cm. Distanza delle sospensioni: 200 x 200 cm.

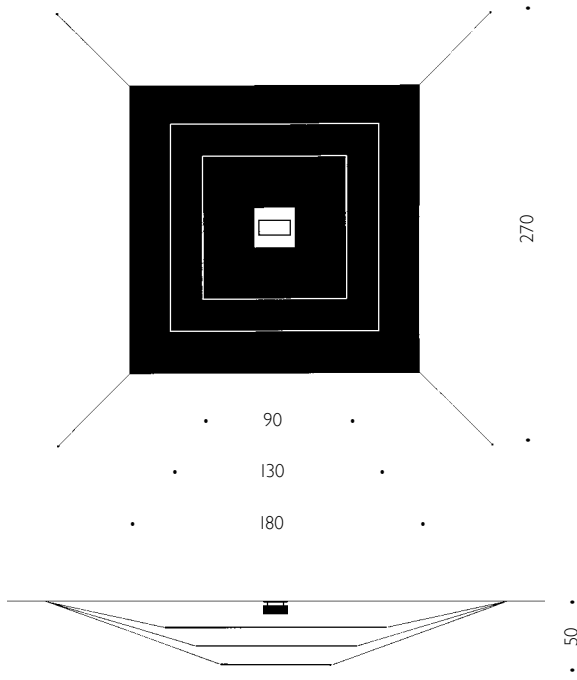

**Luxury Pure**

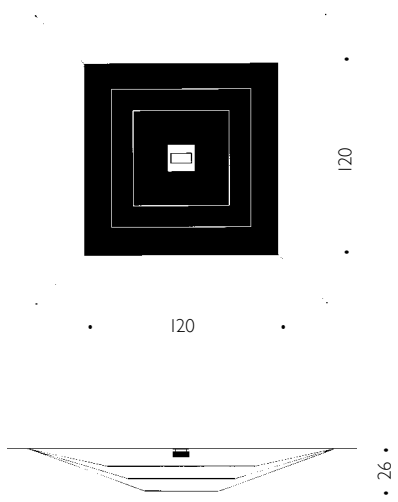

**Lil Luxury**



Lil Luxury

Auch erhältlich in Weiß – Also available in white – Disponible aussi en blanc  
Anche disponibile in bianco



**Spock** *Bernhard Dessecker 1998*

Edelstahl, Glas, Aluminium. Der Strahler ist über ein Kugelgelenk einstellbar. Aufputz-Montagedose mit Abdeckscheibe Ø 8 cm. Die Montage auf eine Unterputzdose ist ebenfalls möglich. Auch an der Wand zu montieren. Lieferung mit Leuchtmittel. ■ Stainless steel, glass, aluminium. Adjustable via ball-joint. Box with cover Ø 8 cm, for surface mounting. Flush mounting also possible, or can be fixed to wall. Complete with bulb. ■ Acier inoxydable, verre, aluminium. Le spot est orientable par articulation à rotule. Boîte pour le montage sur crépi avec rondelle de recouvrement Ø 8 cm. Le montage sur une boîte encastrable sous crépi est également faisable. Possibilité de montage en applique. Livrée avec ampoule. ■ Acciaio inossidabile, vetro, alluminio. Il faretto è regolabile mediante un giunto sferico. Scatola di derivazione esterna a soffitto con rosone Ø cm. 8. Possibilità di montaggio con una scatola di derivazione incassata. E' possibile montarla anche a parete. Lampadina inclusa.

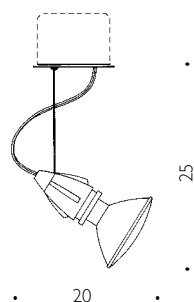

 52 W PAR 30° Halogen, 550 lm, 2800 K, 1500 h, EEC C

 E27 glass, max. 75 W, A++-E



**Sista Bernhard Dessecker 1998**

Metall, Kunststoff. Glasfassung direkt mit dem transparenten Baldachin verbunden. Lieferung mit Leuchtmittel. ■ Metal, plastic. Glass socket directly integrated into the transparent canopy. Complete with bulb. ■ Métal, matière plastique, verre. Douille en verre liée directement au baldachin transparent. Livrée avec ampoule. ■ Metallo, materiale sintetico. Portalampada in vetro direttamente collegato al rosone trasparente. Lampadina incluse.

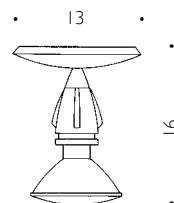

 52 W PAR 30° Halogen, 550 lm, 2800 K, 1500 h, EEC C

 E27 glass, max. 75 W, A++-E

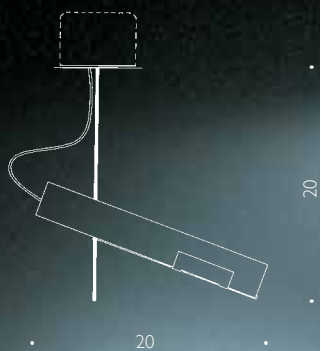

**Zuuk** Ingo Maurer 1994

Edelstahl, farblos eloxiertes Aluminium, hitzebeständiges satiniertes Glas. Nicht verstellbar. Lieferung mit Leuchtmittel, Aufputz-Montagedose und eloxierter Abdeckscheibe Ø 8 cm. Die Montage auf eine Unterputzdose ist ebenfalls möglich. ■ Stainless steel, anodized aluminium, heat-resistant satin-frosted glass. Non-adjustable. Complete with bulb, surface-mounted ceiling fixture and anodized base-plate cover Ø 8 cm. Flush mounting also possible. ■ Acier inoxydable, aluminium anodisé incolore, verre satiné résistant à la chaleur. Pas de possibilité de réglage en hauteur. Livrée avec ampoule, boîtier pour le montage sur crépi et rondelle de recouvrement Ø 8 cm en aluminium anodisé. Possibilité de montage en applique. ■ Acciaio inossidabile, alluminio anodizzato naturale, vetro satinato termoresistente. Non regolabile. Lampadina, scatola di derivazione esterna e rosone anodizzato Ø cm. 8 inclusa. E' possibile montarla anche su una scatola di derivazione incassata.

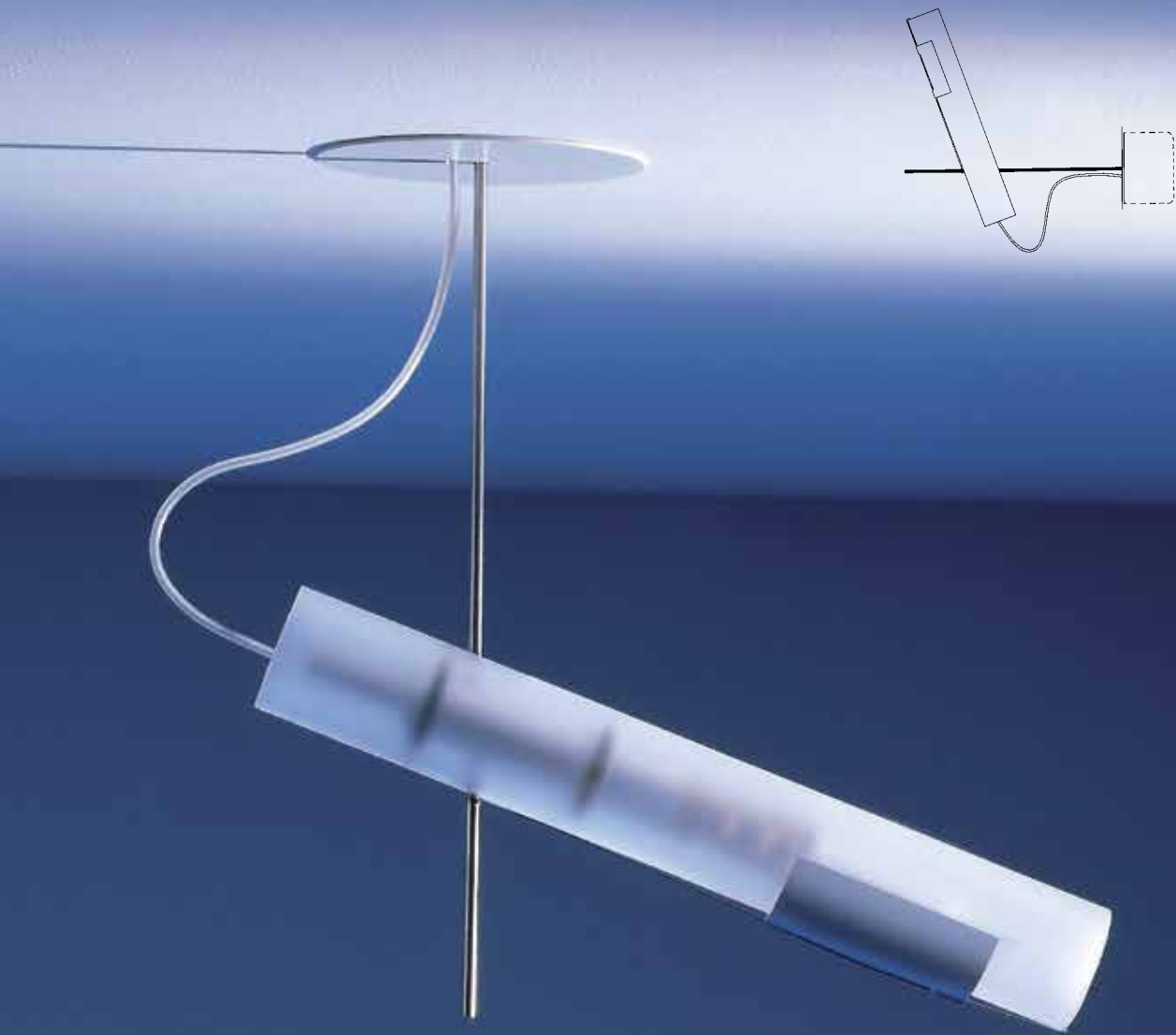

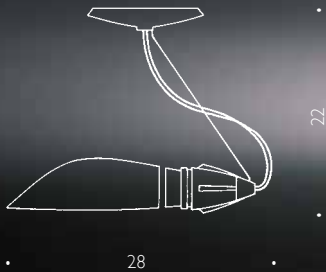

### **Lampeduso** *Bernhard Dessecker 1994*

Kunststoff, Glas, Metall. Blende aus hitzebeständigem Glasgewebe. Empfohlene Leuchtmittel: Kompakt-Leuchtstofflampe 7/11 Watt oder Halogen-Röhrenlampe, max. 60 Watt. Baldachin Ø 13 cm, transparent. Lieferung ohne Leuchtmittel. ■ Plastic, glass, metal, heat-resistant glass fabric shade. Recommended bulbs: compact fluorescent bulb 7/11 watts or halogen tubular lamp, max 60 watts. Canopy Ø 13 cm, transparent. Bulb not included. ■ Matière plastique, verre, métal. Ecran en fibre de verre résistant à la chaleur. Ampoules recommandées: ampoule fluorescente compacte 7/11 watts ou ampoule halogène tube, max. 60 Watt. Baldaquin, Ø 13 cm, transparent. Livrée sans ampoule. ■ Materiale sintetico, vetro, metallo. Schermo in tessuto di vetro termoresistente. Lampadine consigliate: lampada fluorescente 7/11 watt o lampadina alogena tubolare, max. 60 watt. Rosone Ø cm. 13, trasparente. Lampadina non inclusa.

**One lamp, two uses: ceiling or wall.**

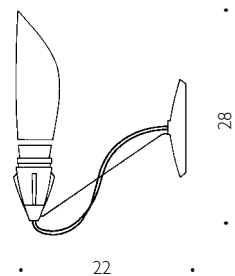





### **Tooling** *Christoph Matthias 2004*

Aluminium, Edelstahl, Kunststoff. Leuchtenkopf um 180° drehbar und um 45° schwenkbar. Der Reflektor ist matt grau lackiert. Aufputzmontage mit Abdeckscheibe Ø 8 cm. Die Montage ist auch auf Unterputzdose möglich. Lieferung mit Leuchtmittel. ■ Aluminium, stainless steel, plastic. Head of lamp rotates through 180° and tilts through 45°. The reflector has a mat grey finish. With surface-mounted wall fixture and base-plate cover Ø 8 cm. Flush-mounted installation is also possible. Complete with bulb. ■ Aluminium acier inoxydable, matière plastique. Tête de lampe rotative à 180° et inclinable à 45°. Montage sur crépi avec rondelle de recouvrement Ø 8 cm. Montage sur boîtier encastrable sous crépi possible. Livrée avec ampoule. ■ Alluminio, acciaio inossidabile, materiale sintetico. Il riflettore ruota di 180° e si inclina di 45°. La superficie esterna del riflettore è verniciata grigio opaco. Scatola di derivazione esterna con piastra di copertura Ø 8 cm. È possibile il montaggio su una scatola di derivazione incassata. Lampadina inclusa.



**Use Me C.** Ingo Maurer und Team, 2010

Edelstahl, Aluminium. Der Strahler ist über ein Kugelgelenk einstellbar. Das Leuchtmittel ist im Handel auch in anderen Ausstrahlungswinkeln und Wattagen erhältlich. Lieferung mit Leuchtmittel. ■ Stainless steel, aluminium. Adjustable via one ball-joint. In trade the light source is also available with other angles and wattages. Complete with bulb. ■ Acier inoxydable, aluminium. Spot ajustable par une articulation à rotule. L'halogène est aussi disponible en magasin avec d'autres angles et wattages. Livrée avec ampoule. ■ Acciaio inossidabile, alluminio. Il faretto è regolabile mediante un giunto a sfera. La lampadina è anche disponibile in commercio con altri angoli d'irradiazione e wattaggi. Lampadina inclusa.

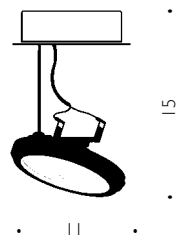
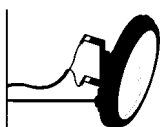

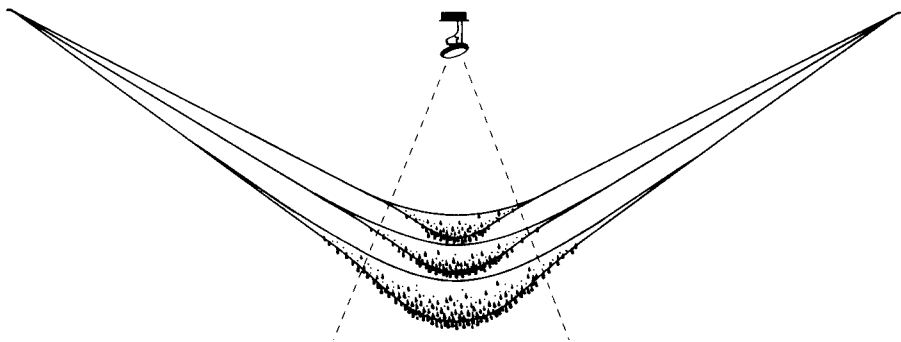

Use Me C. can be used as a downlight combination with  
Lacrime del Pescatore, both sold separately.



**Light Cones:  
Downlight solution 1, 2 + 3**

**Fünf unterschiedliche Deckeneinbaulampen für Downlight-Lösungen, die über das Übliche hinausgehen.**

**Five different lighting options, to create solutions for downlighting that are certainly beyond the ordinary.**



**Schlitz Up:**  
**Downlight solution 4 + 5**

**Cinq options différentes d'éclairage pour créer des solutions d'éclairage vers le bas, sortant de l'ordinaire.**

**Cinque opzioni d'illuminazione differenti, per creare un'illuminazione singolare verso il basso.**

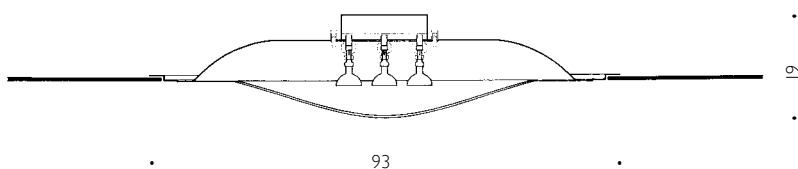
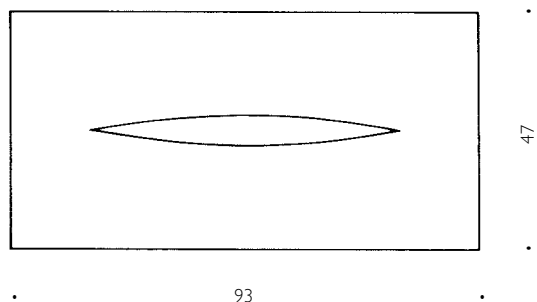

### **Schlitz Up** Ingo Maurer 2002

Aluminium, GFK. Deckenlampe für Einbau in abgehängte Decken, Einbautiefe min. 15 cm. Sondergrößen auf Anfrage. Durch Kugelgelenke justierbare Multi Mirror-Reflektoren lenken das Licht an verschiedene Positionen. Die Innenflächen können auf Wunsch auch in anderen kontrastreichen Farben lackiert werden. ■ Aluminium, glass fibre. Ceiling lamp for flush mounting into lowered ceilings, installation depth 15 cm min. Alternative dimensions on request. Multimirror reflectors, adjustable by means of ball-joints, direct the light to various positions. On request, the inner surface can be lacquered in several contrast colours. ■ Aluminium, fibre de verre. Plafonnier pour montage sur plafonds surbaissés, profondeur de montage 15 cm. Dimensions spéciales sur demande. Des réflecteurs Multi Mirror réglables par des articulations à rotule dirigent la lumière dans des positions diverses. Les surfaces intérieures peuvent être laquées sur demande dans d'autres couleurs plus contrastées. ■ Alluminio, vetroresina. Lampada da soffitto per l'incasso in controsoffitti, profondità di montaggio 15 cm. Misure speciali su richiesta. Grazie a riflettori Multi Mirror regolabili tramite giunti sferici, la luce può essere diretta in varie posizioni. Le superfici interne possono essere verniciate in altri colori contrastanti su richiesta.

💡 3 x 7,5 W LED Spot, 420 lm, 2700 k, CRI >85, EEC A. Dimmable. 🌀 GU 10, max. 8 W, A++-A  
 125 volts version: bulbs not included.

### Light Cone L Ingo Maurer 2005

Fibreglas. Für fugenlosen Einbau in abgehängte Decken, Einbautiefe 23 cm. CDM-Version nur für 230 Volt: Einbautiefe 24 cm. Mit elektronischem Vorschaltgerät. Lieferung mit Leuchtmittel. ■ Fibreglass. For flush mounting in lowered ceilings, installation depth 23 cm. CDM version for 230 volts only: installation depth 24 cm. With integrated electronic ballast. Complete with bulb. ■ Fibre de verre. Pour montage sur plafonds surbaissés. Profondeur pour montage 23 cm. Version CDM seulement en 230 volts: Profondeur 24 cm. Avec ballast électronique. Livrée avec ampoule. ■ Vetroresina. Per l'incasso in controsoffitti. Profondità di montaggio 23 cm. Versione CDM solo in 230 volt: Profondità di montaggio 24 cm. Alimentatore elettronico incluso. Lampadina inclusa.

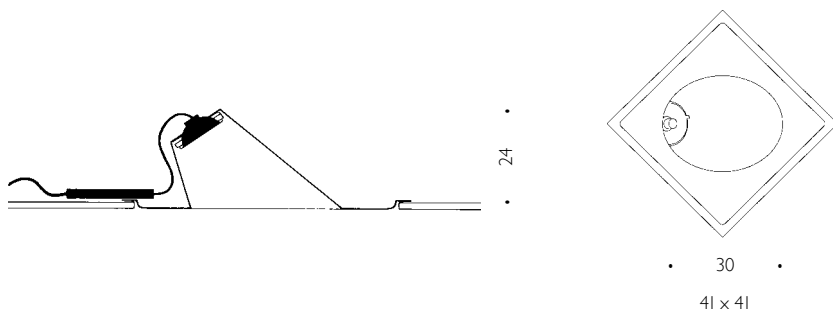

💡 100 W 24° Halogen, 3000 h, 8500 cd, EEC C 🔌 G53, max. 100 W, A++-E ⚡ 230/125/12 V  
 LED version: technical data on request. Recommended retrofit LED bulb for 230 volts available through Ingo Maurer.

### Light Cone S / Light Cone S vertical Ingo Maurer 2005

Fibreglas. Für fugenlosen Einbau in abgehängte Decken, Einbautiefe 18 cm. Lieferung mit Leuchtmittel. ■ Fibre-glass. For flush mounting in lowered ceilings. Installation depth 18 cm. Complete with bulb. ■ Fibre de verre. Pour montage sur plafonds surbaissés. Profondeur pour montage 18 cm. Livrée avec ampoule. ■ Vetroresina. Per l'incasso in controsoffitti. Profondità di montaggio 18 cm. Lampadina inclusa.

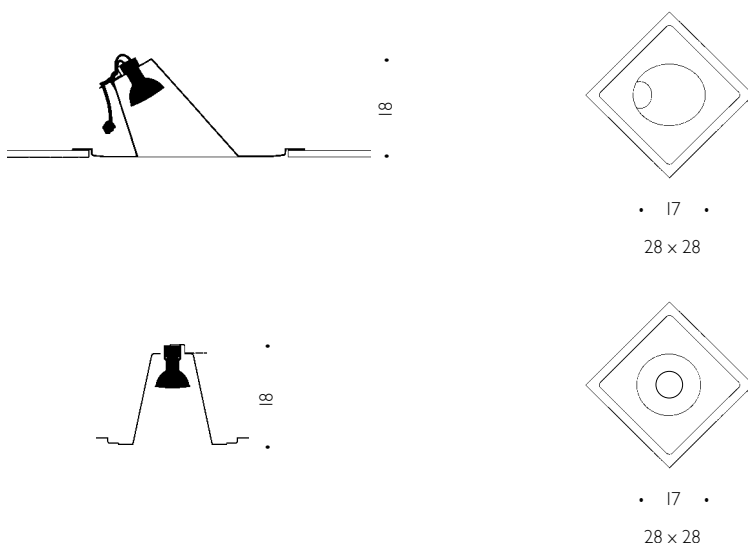

💡 75 W 25° Halogen, 2500 h, 2500 cd, EEC C 🔌 GU10, max. 75 W, A++-E  
 Recommended retrofit LED bulb for 230 volts available through Ingo Maurer.

SCHLITZ UP  
VIEW FROM BELOW INTO OPEN RECESSED CEILING

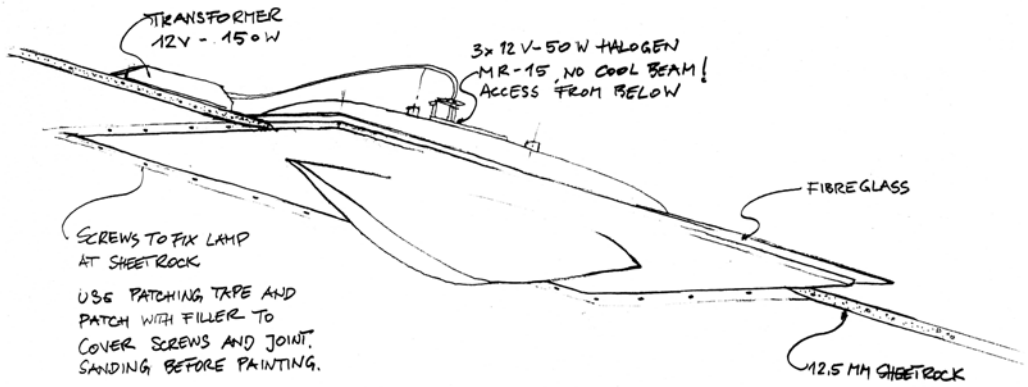

LIGHT CONE  
PERSPECTIVE VIEW INTO RECESSED CEILING

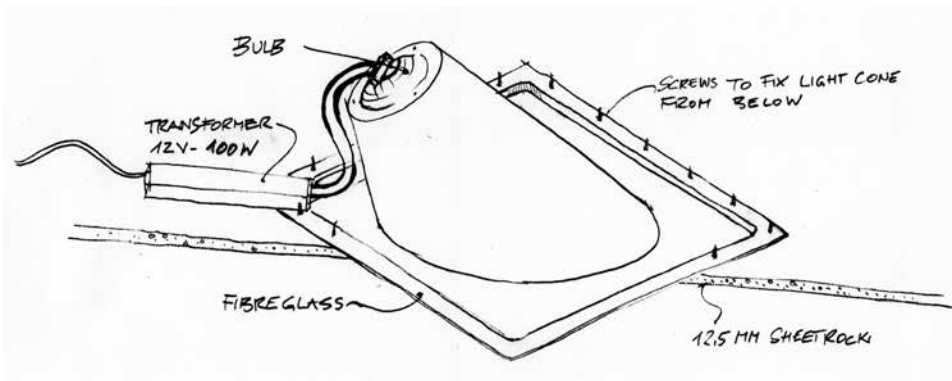



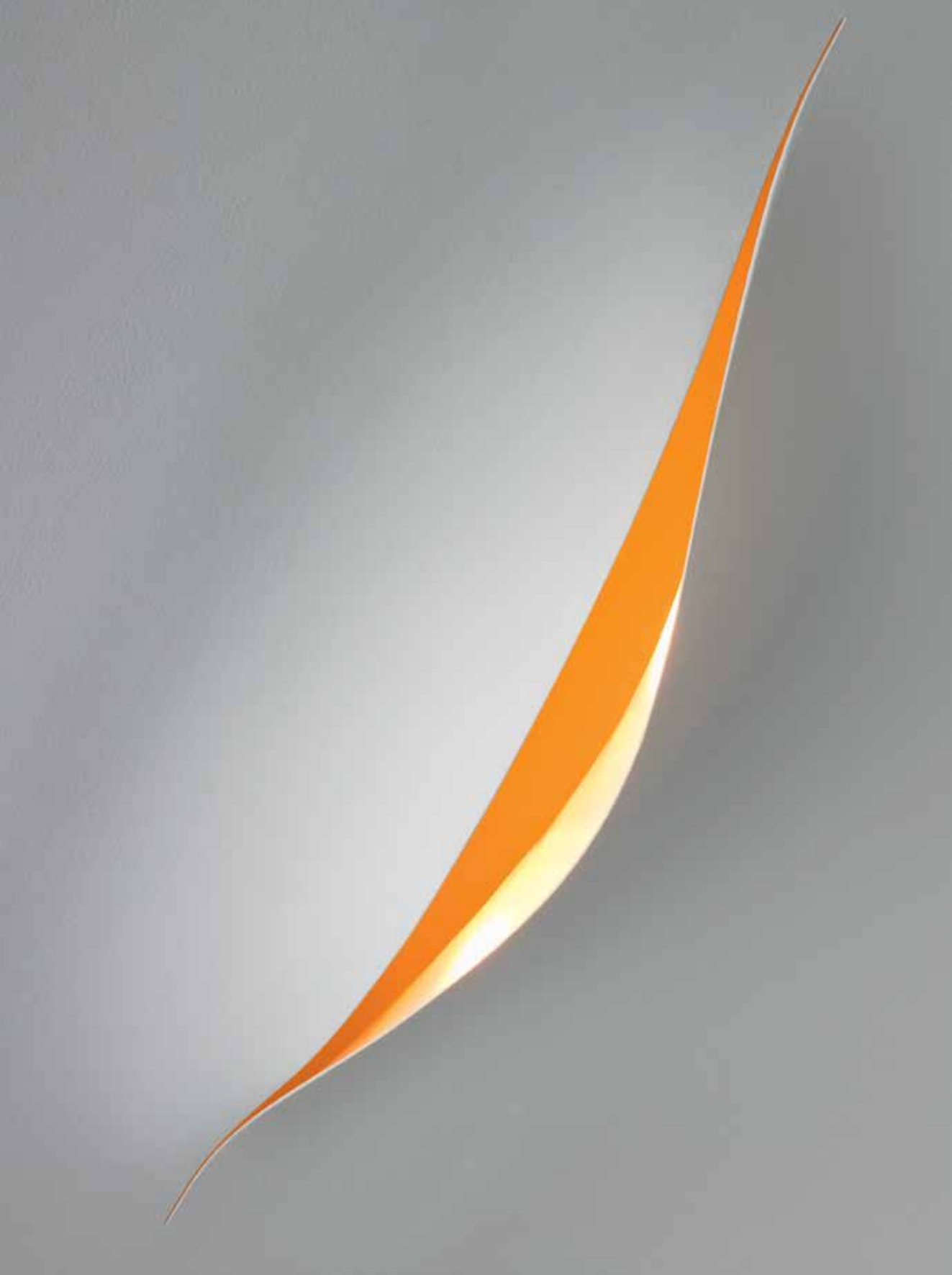

Schlitz Up, custom colour

my answer to boring  
downlights:  
'Schlitz Up'! Just an elegant  
cut in the ceiling.

250 or 450 x 50 cm. Custom sizes available on request.

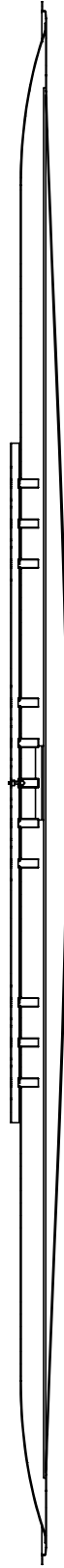
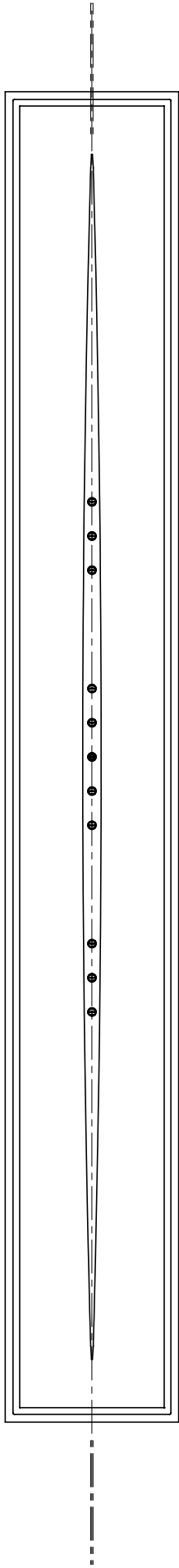





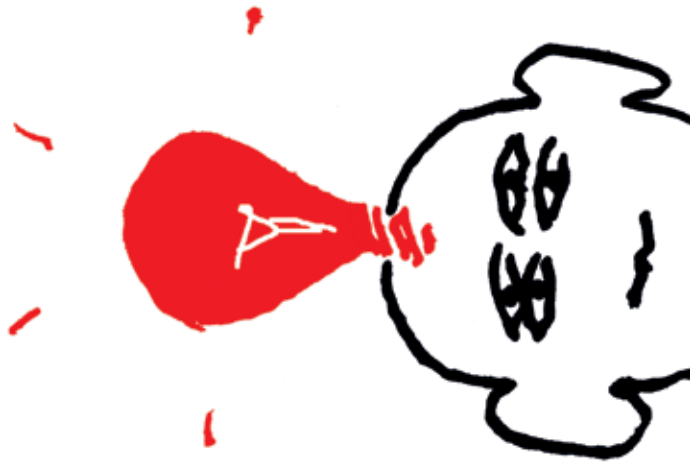

Wandlampen / Wall lamps / Appliques / Lampade da parete



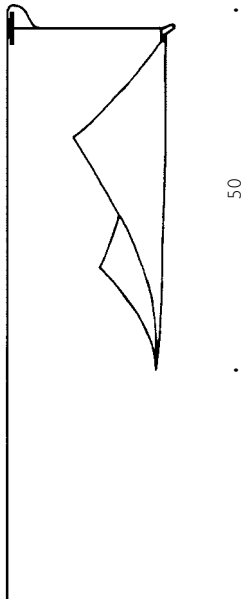

28

## A magnificent new LED high-tech development turned into poetry.

### **Dew Drops Wall** Ingo Maurer Team 2014

Transparente Kunststoffolie mit integrierten LEDs, Metall. Die Folie ist an einer Ecke aufgehängt und fällt fast wie ein Tuch. Die Form lässt sich mit einem schlichten Metallstäbchen fixieren. Mit Sensorschalter zum Anschalten und Dimmen auf der Folie. ■ Transparent plastic sheet with integrated LEDs, metal. Suspended at one corner, the sheet is reminiscent of a cloth. The shape is adjustable with a metal pin. With a dimmable touch sensor switch on the sheet. ■ Film plastique transparent avec LEDs intégrés, métal. Le film plastique est accroché dans un coin et fait penser à un tissu qui pend. Une simple baguette en métal permet de fixer le film plastique. Avec interrupteur à sensor tactile pour allumer et faire varier l'intensité de la lumière sur le film plastique. ■ Pellicola trasparente in materiale sintetico con LED integrati, metallo. La pellicola è fissata da un angolo e ricorda un tessuto appeso. La sua forma può essere mantenuta con una semplice astina di metallo. Interruttore a sensore sulla pellicola stessa per accendere, spegnere e dimmerare.



**Lucellino** Ingo Maurer 1992

Glas, Messing, Kunststoff, handgefertigte Flügel aus Gänsefedern. Transformator erforderlich. Lieferung mit Ersatzglühlampe und weißer Abdeckscheibe Ø 8,5 cm. Nicht geeignet für Räume mit hoher Luftfeuchtigkeit. ■ Glass, brass, plastic, hand-crafted goosefeather wings. Transformer required. Complete with spare bulb and white base-plate Ø 8,5 cm. Not suited for rooms with high humidity. ■ Verre, laiton, matière plastique, ailes confectionnées à la main en plumes d'oie. Transformateur obligatoire. Livrée avec une ampoule de rechange et une rondelle de recouvrement blanche Ø 8,5 cm. N'est pas appropriée pour des pièces avec un fort taux humidité. ■ Vetro, ottone, materiale sintetico, ali in piume d'oca lavorate a mano. E' necessario un trasformatore. Lampadina di ricambio e piastra di copertura bianca Ø 8,5 cm incluse. Non adatta all'uso in ambienti con alta umidità.

24V Halogen EU approved

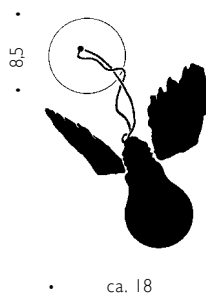





**Lucellino NT** Ingo Maurer 1992

Wandversion mit eingebautem Transformator. Aufputz-Montagedose und weiße Abdeckscheibe Ø 15 cm. Lieferung mit Ersatzglühlampe. Nicht geeignet für Räume mit hoher Luftfeuchtigkeit. ■ Wall version with built-in transformer. Surface-mounting box with white base-plate cover Ø 15 cm. Complete with spare bulb. Not suited for rooms with high humidity. ■ Version murale avec transformateur intégré. Avec boîtier pour montage sur crépi et rondelle de recouvrement blanche Ø 15 cm. Livrée avec ampoule de rechange. N'est pas appropriée pour des pièces avec un fort taux humidité. ■ Versione da parete con trasformatore integrato. Con scatola di derivazione esterna e piastra di copertura bianca Ø 15 cm. Lampadina di ricambio inclusa. Non adatta all'uso in ambienti con alta umidità.

24V Halogen EU approved

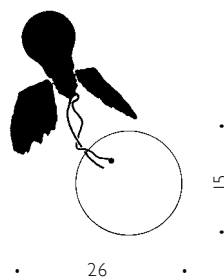



95

ca. 40

**Seven off the Wall** Ingo Maurer und Team 2010

Technische Angaben wie Birdie's Busch, Seite 210. ■ Technical details see Birdie's Busch, page 210. ■ Détails techniques comme Birdie's Busch, page 210. ■ Dettagli tecnici come Birdie's Busch, pagina 210.

24V Halogen EU approved





**Holonzki / Dead Bulb Alive\*** Eckard Knuth, Ingo Maurer 2000

Glas-Hologramm 13 x 18 cm, Metall, schwarzes Textilkabel. Auswahl/Festlegung der Hologrammfarbe aus technischen Gründen nicht möglich. Lieferung mit Leuchtmittel. Direkte Sonneneinstrahlung und Nikotin können die Lebensdauer des Hologramms reduzieren. ■ Glass hologram 13 x 18 cm, metal, black fabric cable. For technical reasons, customer choice of hologram colour is not possible. Complete with bulb. Direct sunlight and nicotine may reduce the hologram's life span. ■ Hologramme en verre 13 x 18 cm, métal, câble de textile noir long de 250 cm. Pour des raisons techniques, le choix de la couleur de l'hologramme n'est pas possible. Livrée avec ampoule. Une exposition directe au soleil et à la nicotine peut réduire la durée de vie de l'hologramme. ■ Ologramma in vetro cm. 13 x 18, metallo, cavo tessile nero. Per ragioni tecniche non è possibile la scelta del colore dell'ologramma. Lampadina inclusa. L'esposizione diretta al sole e alla nicotina possono ridurre la durata dell'ologramma.



Dead Bulb Alive\*



56

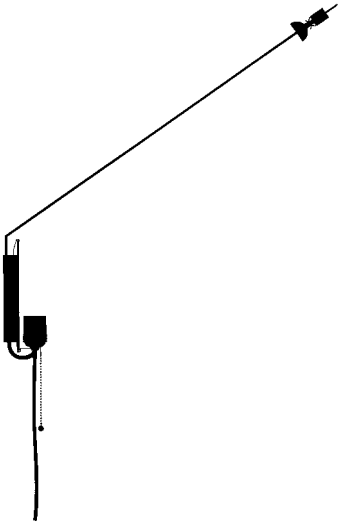

53



**Oskar** Ingo Maurer 1998

Metall, eloxiertes Aluminium, Reflektor mit Schutzglas. Transformator mit integriertem Kippschalter. Ein flexibler Metallarm ermöglicht die variable Einstellung des Reflektors. Lieferung mit Leuchtmittel. ■ Metal, anodized aluminium, reflector with protective glass cover. Transformer with integrated toggle switch. A flexible metal arm allows variable adjustment of the reflector. Complete with bulb. ■ Métal, aluminium anodisé, réflecteur avec verre protecteur. Transformateur avec interrupteur à bascule intégré. Un bras métallique flexible permet le réglage variable du réflecteur. Livrée avec ampoule. ■ Metallo, alluminio anodizzato, riflettore con vetro di protezione. Trasformatore con interruttore a levetta integrato. Un flessibile braccio metallico permette la regolazione variabile del riflettore. Lampadina inclusa.

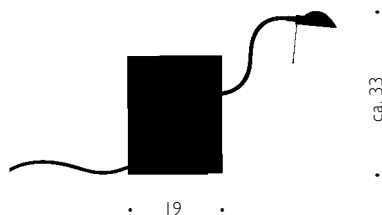

• 19 •

ca. 33

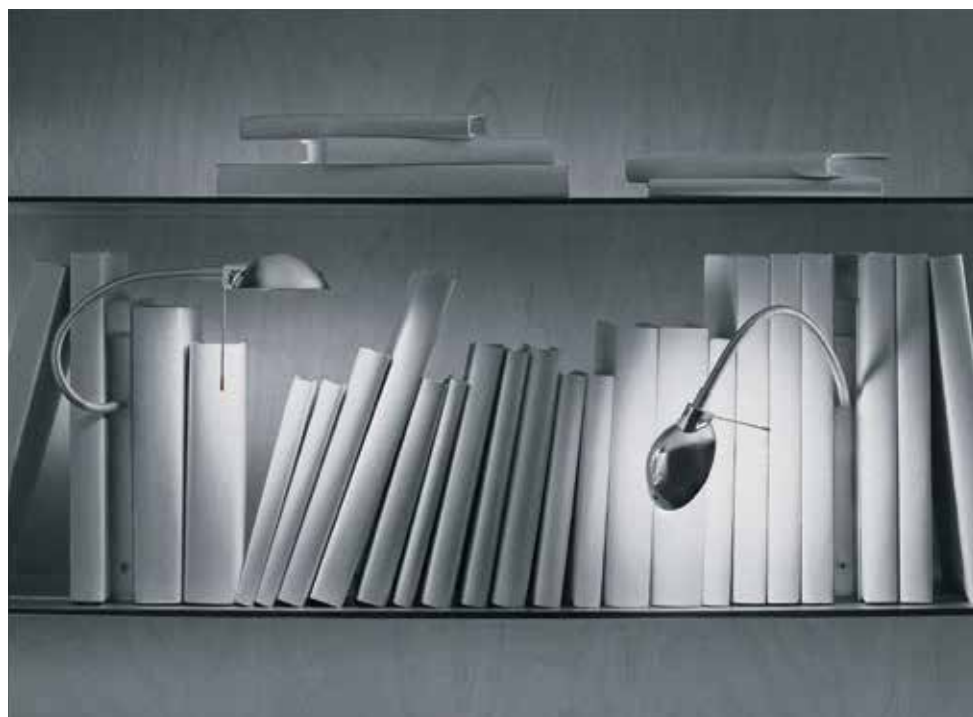

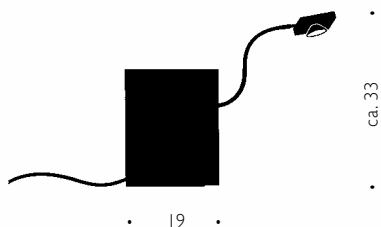

### **LED's Oskar** *Ingo Maurer und Team 2012*

Schwarz eloxiertes Aluminium, Silber, Metall. Ein flexibler Metallarm ermöglicht die variable Einstellung des Kopfes. Elektronischer Sicherheitstransformator mit integriertem Kippschalter. Mit eingebauter LED. ■ Anodised aluminium in black, silver, metal. The flexible metal arm allows variable adjustment of the lamp head. Electronic safety transformer with integrated toggle switch. With built-in LED. ■ Aluminium anodisé noir, argent, métal. Le bras métallique flexible permet le réglage variable du réflecteur. Transformateur électronique de sécurité avec interrupteur à bascule intégré. Avec LED intégré. ■ Alluminio anodizzato nero, argento, metallo. Il braccio metallico flessibile permette la regolazione variabile del riflettore. Trasformatore di sicurezza elettronico con interruttore a levetta integrato.









**zero-one** Ingo Maurer und Team 1990

Weißes Corian, mattierter Spiegel. Der bewegliche Spiegel dient zur Lichtumlenkung. Lieferung mit Leuchtmittel. ■ Corian, white, frosted mirror. The direction of the light can be altered by adjusting the position of the mirror. Complete with bulb. ■ Corian blanc, miroir mat. Le miroir mobile permet de modifier le faisceau lumineux. Livrée avec ampoule. ■ Corian bianco, specchio smerigliato. Lo specchio regolabile serve per indirizzare la luce. Lampadina inclusa.

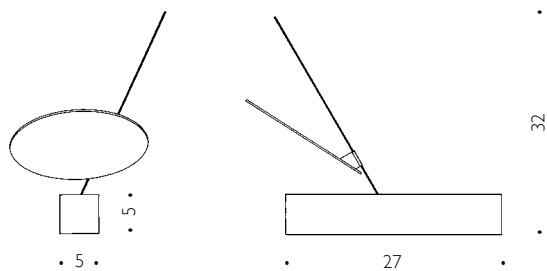

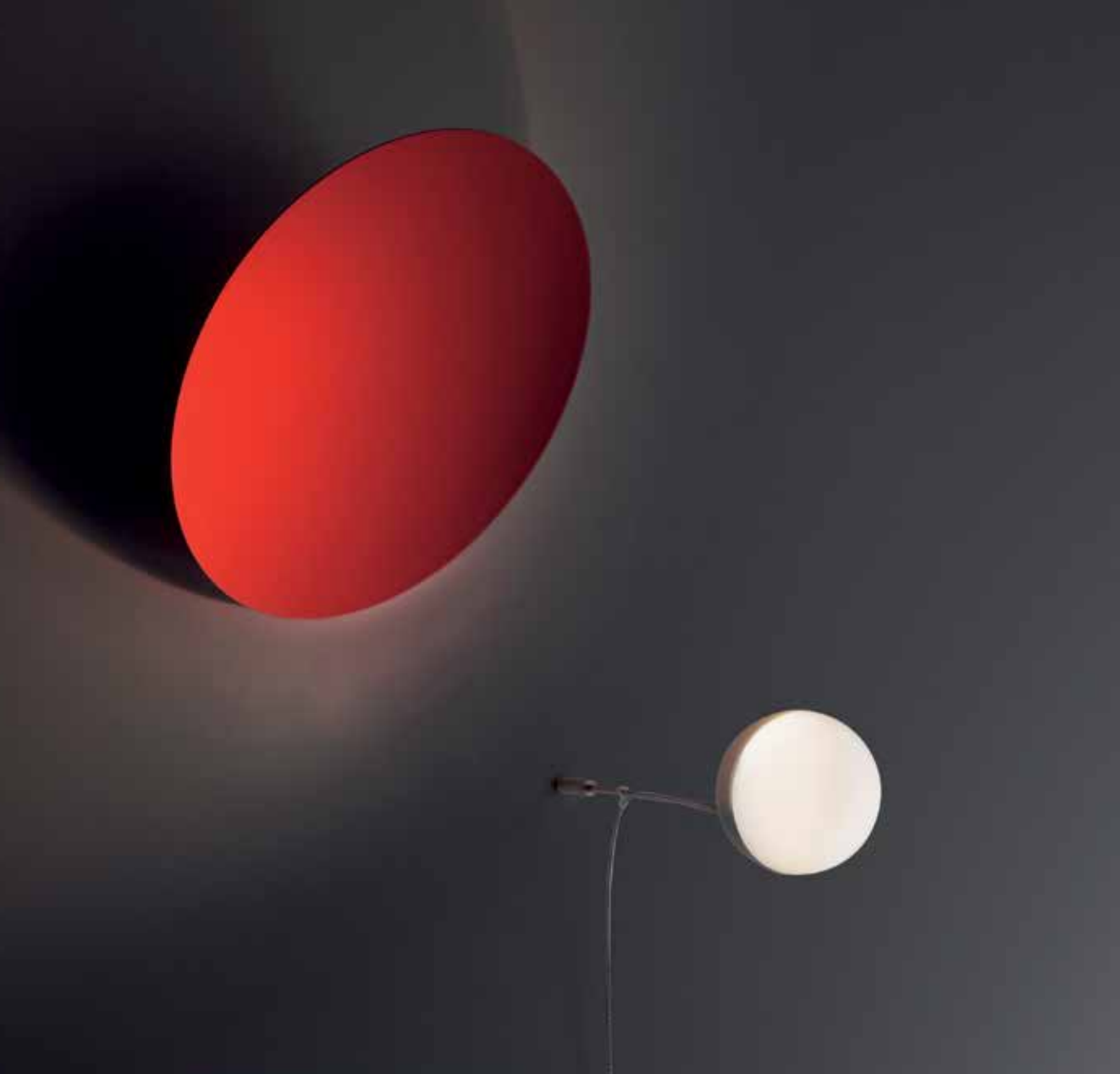

**Aka\_Tsuki Matthias Liedtke 2003**

Metall, Glas. Aus einer Opalglasskugel Ø 8,5 cm angestrahlt, scheint eine rot pigmentierte Schale räumlich vor der Wand zu schweben. Lieferung mit Leuchtmittel. ■ Metal, glass. Illumination comes from wall mounted opaline glass ball Ø 8,5 cm, a red-pigmented bowl seems to be floating three-dimensionally on the wall. Complete with bulb. ■ Métal, verre. Eclairée par une sphère opaline, Ø 8,5 cm, une soucoupe pigmentée de rouge semble flotter en trois dimensions devant le mur. Livrée avec ampoule. ■ Metallo, vetro. Illuminata da una sfera opalina, Ø 8,5 cm, un piatto colorato rosso sembra galleggiare tridimensionalmente davanti alla parete. Lampadina inclusa.

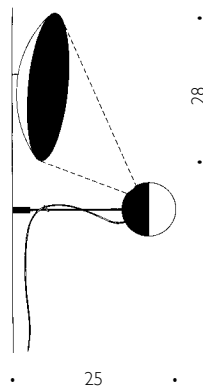

 35 W 36° Halogen, 480 lm, 3000 K, 4000 h, EEC B

 GU 4, max. 35 W, A++-E  230/125/12 V  200 cm



**Use Me W.** Ingo Maurer 2010

Edelstahl, Aluminium. Der Strahler ist über zwei Kugelgelenke einstellbar. Transparentes Kabel mit Schalter. Mit integriertem elektronischen Transformator. Das Leuchtmittel ist im Handel auch in anderen Ausstrahlungswinkeln und Wattagen erhältlich. Lieferung mit Leuchtmittel. ■ Stainless steel, aluminium. Adjustable via two ball-joints. Transparent cable with switch. Integrated electronic transformer. In trade the light source is also available with other angles and wattages. Complete with bulb. ■ Acier inoxydable, aluminium. Spot ajustable par deux articulations à rotule. Câble avec interrupteur, non dimmable. L'halogène est aussi disponible en magasin avec autres angles et wattages. Livrée avec transformateur électronique intégré et ampoules. ■ Acciaio inossidabile, alluminio. Il faretto è regolabile mediante due giunti a sfera. Cavo con interruttore, non dimmerabile. Trasformatore elettronico integrato. La lampadina è anche disponibile in commercio con altri angoli d'irradiazione e wattaggi. Lampadina inclusa.

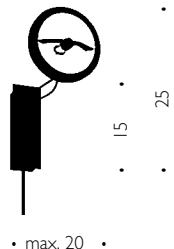

 100 W 6° Halogen, 3000 h, EEC B  G53, max. 100 W, A++-E

 230/125/12 V  300 cm transparent

• max. 20 •



### **Wandering Finger Wall** *Ingo Maurer 1995*

Edelstahl, eloxiertes Aluminium, hitzebeständiges Schutzglas. Der Reflektor ist über ein Kippgelenk verstellbar. Mit Leuchtmittel, Aufputz-Montagedose und aluminium-farbener Abdeckscheibe Ø 8 cm. Die Montage auf einer Unterputzdose ist ebenfalls möglich. ■ Stainless steel, anodized aluminium, heat-resistant protective glass cover. The ball-and-socket joint makes the reflector angle freely adjustable. Complete with bulb, surface-mounted ceiling fixture and aluminium-finish base-plate cover Ø 8 cm. Flush mounting also possible. ■ Acier inoxydable, aluminium anodisé, verre protecteur résistant à la chaleur. Le réflecteur est orientable par une articulation à bascule. Livrée avec ampoule, boîtier pour le montage sur crépi et rondelle de recouvrement de couleur aluminium Ø 8 cm. Possibilité de montage en applique. ■ Acciaio inossidabile, alluminio anodizzato, vetro di protezione termoresistente. Il riflettore è regolabile mediante un giunto basculante. Lampadina, scatola di montaggio e rosone di colore alluminio Ø cm. 8 inclusi. È possibile montarla anche su una scatola da incasso. ■ Acero inoxidable, aluminio galvanizado, vidrio protector termorresistente. El reflector puede reajustarse mediante una articulación en la base. Suministrada con bombilla, Incluye caja de montaje en el florón color aluminio de Ø 8 cm. También es posible montar sobre una caja debajo del revoque.

**Delight** Frans van Nieuwenborg, Martijn Wegman 1980

Hitzebeständiges Glasgewebe, Dauerbelastung bis 180° C möglich. Tuchformat 75 x 75 cm. Lieferung ohne Glühlampe. ■ Heat-resistant glass fabric. Capable of withstanding continuous use at temperatures of up to 180° C. Cloth size 75 x 75 cm. Bulb not included. ■ Fibre de verre résistant à la chaleur; supporte une chaleur continue jusqu'à 180°C max. Format du tissu en fibre de verre 75 x 75 cm. Livrée sans ampoule. ■ Tessuto in fibre di vetro termoresistente. Sostiene calore continuo fino a 180°C. Misure del tessuto cm. 75 x 75. Lampadina non inclusa.



 E27, max. 40 W, A++-E  180 cm white

Recommended retrofit LED bulb for 230 volts available through Ingo Maurer.





**Light au Lait** Fabien Dumas, Ingo Maurer und Team 2004

Steingut, Silikon, Edelstahl. Durch Kugelgelenk um 180° drehbar und um 30° verstellbar. Eingebauter Zugschalter mit Löffel. Mit Aufputz-Montagedose. Die Montage ist auch auf Unterputzdose möglich. Lieferung mit Leuchtmittel. ■ Stoneware, silicone, stainless steel. The lamp swivels through 180° and can be bent down up to 30° by means of a ball joint. Integrated pull switch with spoon. Including surface-mounting box. Flush-mounted installation is also possible. Complete with bulb. ■ Faïence, silicone, acier inoxydable. Rotative et inclinable respectivement de 180° et 30° par une articulation à bille. Interrupteur à tirette intégré dans la cuillère. Avec boîtier pour montage sur crépi. Le montage sur boîtier sous crépi est également possible. Livrée avec ampoule. ■ Maiolica, silicone, acciaio inossidabile. Orientabile di 180° e inclinabile di 30° mediante un giunto sferico. Interruttore a catenella con cucchiaino. Con scatola di derivazione esterna. È possibile il montaggio ad una scatola di derivazione incassata. Lampadina inclusa.

 60 W Halogen, 980 lm, 2800 K, 2000 h, EEC D

 G9, max. 60 W, A++-E  200 cm with plug





**Canned Light** *Christoph Matthias, Hagen Szech 2003*

Aluminium, Edelstahl, Kunststoff. Eine Konservendose, befüllt mit Glühlampe, Reflektor, Fassung, Kabel und Schalter wird zur Hänge- oder Wandlampe. Aufputz-Montage mit Abdeckscheibe weiß Ø 8 cm. Stufenlos höhenverstellbar durch Umlenkrolle und Justier-ring. ■ Aluminium, stainless steel, plastic. A tin can, containing lightbulb, reflector, socket, cable and switch, turns into a hanging or wall lamp. Surface-mounted ceiling fixture with white baseplate cover Ø 8 cm. Height freely adjustable with pulley and ring. ■ Aluminium, acier inoxydable, matière plastique. Une boîte de conserves, contenant ampoule, réflecteur, douille, câble, interrupteur se transforme en suspension ou applique. Montage sur crépi avec rondelle blanche de recouvrement Ø 8 cm. Réglable en hauteur sans graduation par poulie de renvoi et anneau coulissant. ■ Alluminio, acciaio inossidabile, materiale sintetico. Un barattolo da conserva, contenente lampadina, portalampada, riflettore, cavo e interruttore, si trasforma in una lampada a sospensione o da parete. Scatola di derivazione esterna con piastra bianca di copertura Ø 8 cm. Regolazione continua dell'altezza con carrucola e anello di bloccaggio.

© 2003 and trademark by Campbell Soup Company used under license.  
All rights reserved.





**Max. Wall** *Ingo Maurer und Team 2001*

Aluminium, Fiberglas, Edelstahl. Reflektor um 180° drehbar. Lieferung mit Leuchtmittel.

■ Aluminium, fibreglass, stainless steel. Reflector rotates through 180°. Complete with bulb. ■ Aluminium, fibre de verre, acier spécial. Réflecteur rotatif à 180°. Livrée avec ampoule. ■ Alluminio, vetroresina, acciaio inossidabile. Il riflettore ruota di 180°. Lampadina inclusa.

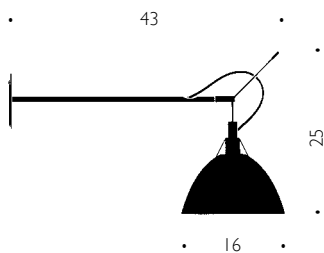

15 W LED, 1300 lm, 2700 K, CRI >90, dimmable, A+



**Tooling** *Christoph Matthias 2004*

Aluminium, Edelstahl, Kunststoff. Leuchtenkopf um 180° drehbar und um 45° schwenkbar. Der Reflektor ist matt grau lackiert. Aufputzmontage mit Abdeckscheibe Ø 8 cm. Die Montage ist auch auf Unterputzdose möglich. Lieferung mit Leuchtmittel. ■ Aluminium, stainless steel, plastic. Head of lamp rotates through 180° and tilts through 45°. The reflector has a mat grey finish. With surface-mounted wall fixture and base-plate cover Ø 8 cm. Flush-mounted installation is also possible. Complete with bulb. ■ Aluminium, acier inoxydable, matière plastique. Tête de lampe rotative à 180° et inclinable à 45°. Montage sur crépi avec rondelle de recouvrement Ø 8 cm. Montage sur boîtier encastrable sous crépi possible. Livrée avec ampoule. ■ Alluminio, acciaio inossidabile, materiale sintetico. Il riflettore ruota di 180° e si inclina di 45°. La superficie esterna del riflettore è verniciata grigio opaco. Scatola di derivazione esterna con piastra di copertura Ø 8 cm. È possibile il montaggio ad una scatola di derivazione incassata. Lampadina inclusa.

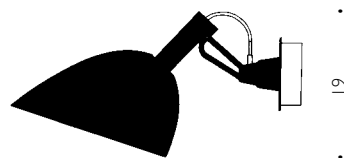

32



**Max. Mover** *Ingo Maurer und Team 2000*

Aluminium, Fiberglas. Das Teleskop ist von 110 auf 210 cm ausziehbar. Durch die Aufhängung an Nylonseilen ist Max. Mover in der Höhe zu verstellen und um 180° drehbar. An seinem Griff kann der Reflektor in zwei Richtungen stufenlos eingerichtet werden. Lieferung mit Leuchtmittel. ■ Aluminium, fibreglass. The telescopic arm extends from 110 to 210 cm, the nylon suspension wires allow for height adjustment and the lamp can be rotated through 180°. The reflector is freely adjustable in two directions, using the handle. Complete with bulb. ■ Aluminium, fibre de verre. Le télescope est extensible de 110 à 210 cm. Suspendu à des fils de nylon, Max. Mover est réglable en hauteur et rotatif à 180°. Grâce à sa poignée, le réflecteur peut être réglé sans graduation dans deux directions. Livrée avec ampoule. ■ Alluminio, vetroresina. Il braccio telescopico è allungabile da cm. 110 a cm. 210. Essendo sospesa a fili di nylon, Max. Mover è regolabile in altezza e ruota di 180°. Agendo sulla leva, il riflettore può essere regolato in continuo in due direzioni. Lampadina inclusa.



One lamp, two uses: ceiling or wall.

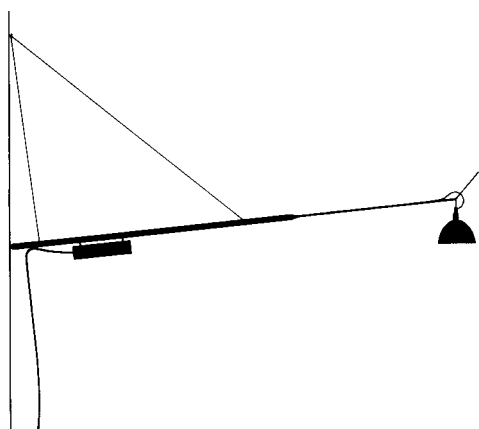

• 110 • max. 100 •





THE MA  
M'D  
NO  
VCHIES

When Ingo Maurer encountered a textile sample made by Dagmar Mombach, it was love at first sight. For the MaMo Nouchies the concept was applied to the unique lightness and modesty of paper which has been one of his favourite materials for many years. Transformed by the elaborate process invented by Dagmar, the paper can be formed in a variety of new ways. Our aim has always been to make lighting that combines visual beauty with technical sophistication and this is exactly how we see The MaMo Nouchies®.

Als Ingo Maurer das erste Mal eine Probe des textilen Materials von Dagmar Mombach sah, verliebte er sich sofort. Für die MaMo Nouchies wurde der Bearbeitungsvorgang für Papier angepasst, das mit seiner einzigartigen Leichtigkeit und Bescheidenheit schon lange ein Lieblingsmaterial von Ingo Maurer ist. Verändert durch den aufwändigen Vorgang, den Dagmar weiterentwickelte, bietet das Papier eine Vielzahl von neuen gestalterischen Möglichkeiten. Unser Ziel war und ist es, Lampen zu machen, die visuelle Schönheit mit technischer Raffinesse verbinden, und genau als das sehen wir The MaMo Nouchies®.



# The MaMoNouchies<sup>®</sup>

A New Tribe of Light

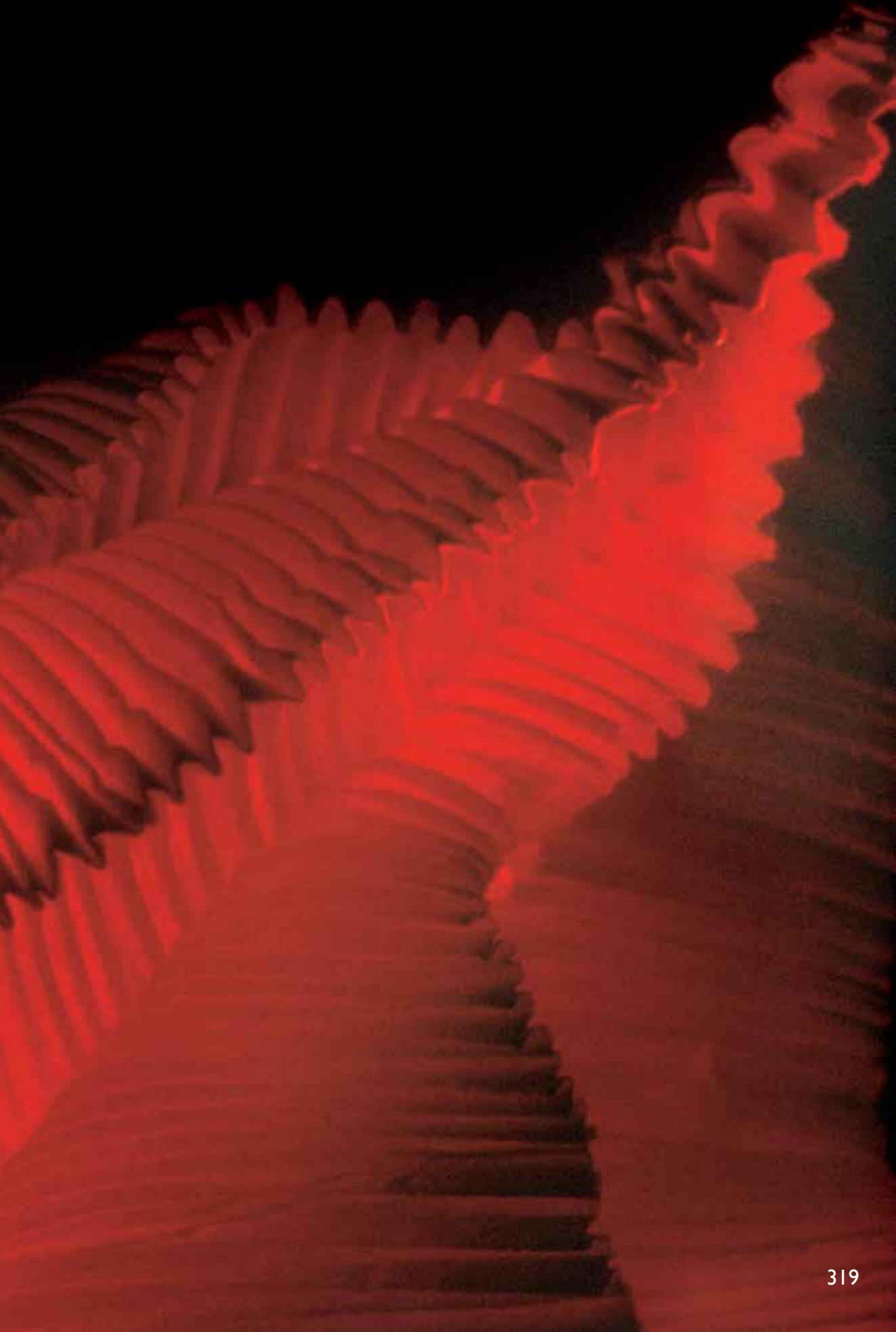

jealous of the moon

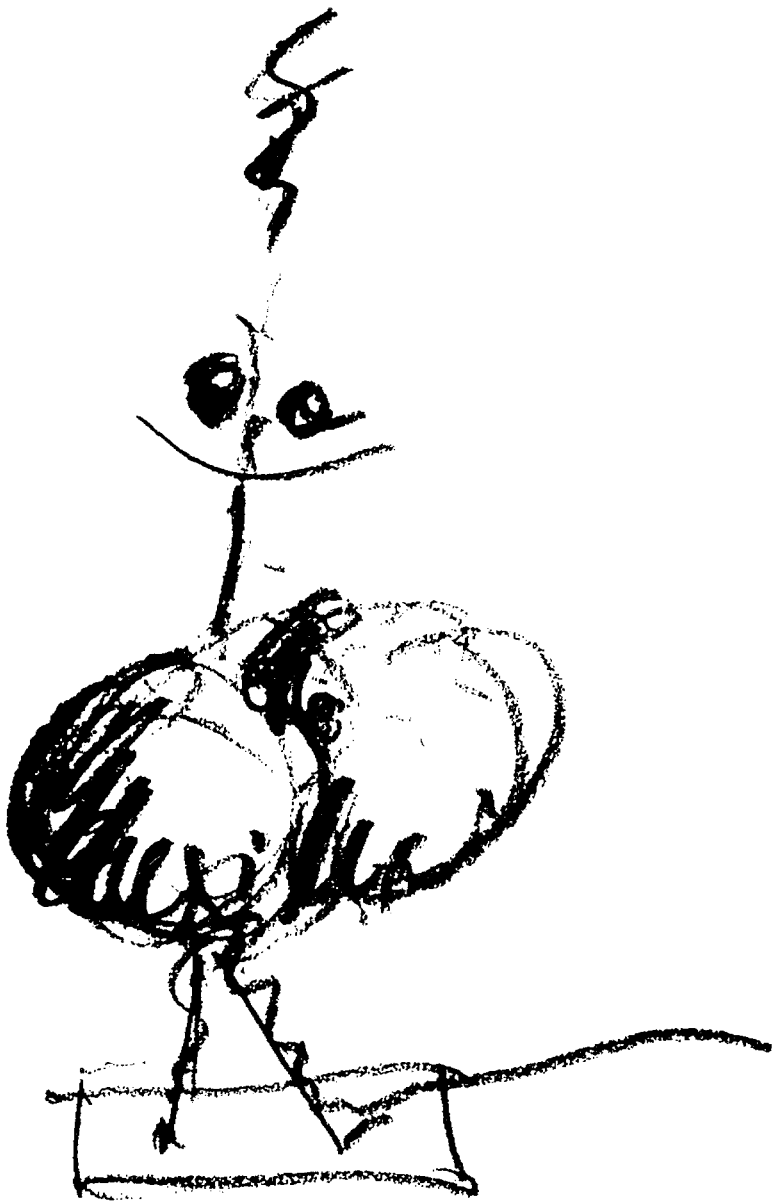



**Kokoro** Dagmar Mombach, Ingo Maurer und Team 1998

Rotes Papier, Metall, Edelstahl, Glas, Kunststoff. Verstellbarer Spiegel. Nicht geeignet für Räume mit hoher Luftfeuchtigkeit. Lieferung mit Leuchtmittel. ■ Red paper, metal, stainless steel, glass, plastic. Adjustable mirror. Not suited for rooms with high humidity. Complete with bulb. ■ Papier rouge, métal, acier inoxydable, verre, matière plastique. Miroir mobile. N'est pas appropriée pour des pièces avec un fort taux humidité. Livrée avec ampoule. ■ Carta rossa, metallo, acciaio inossidabile, vetro, materiale sintetico. Specchio orientabile. Non adatta all'uso in ambienti ad alta umidità. Lampadina inclusa.



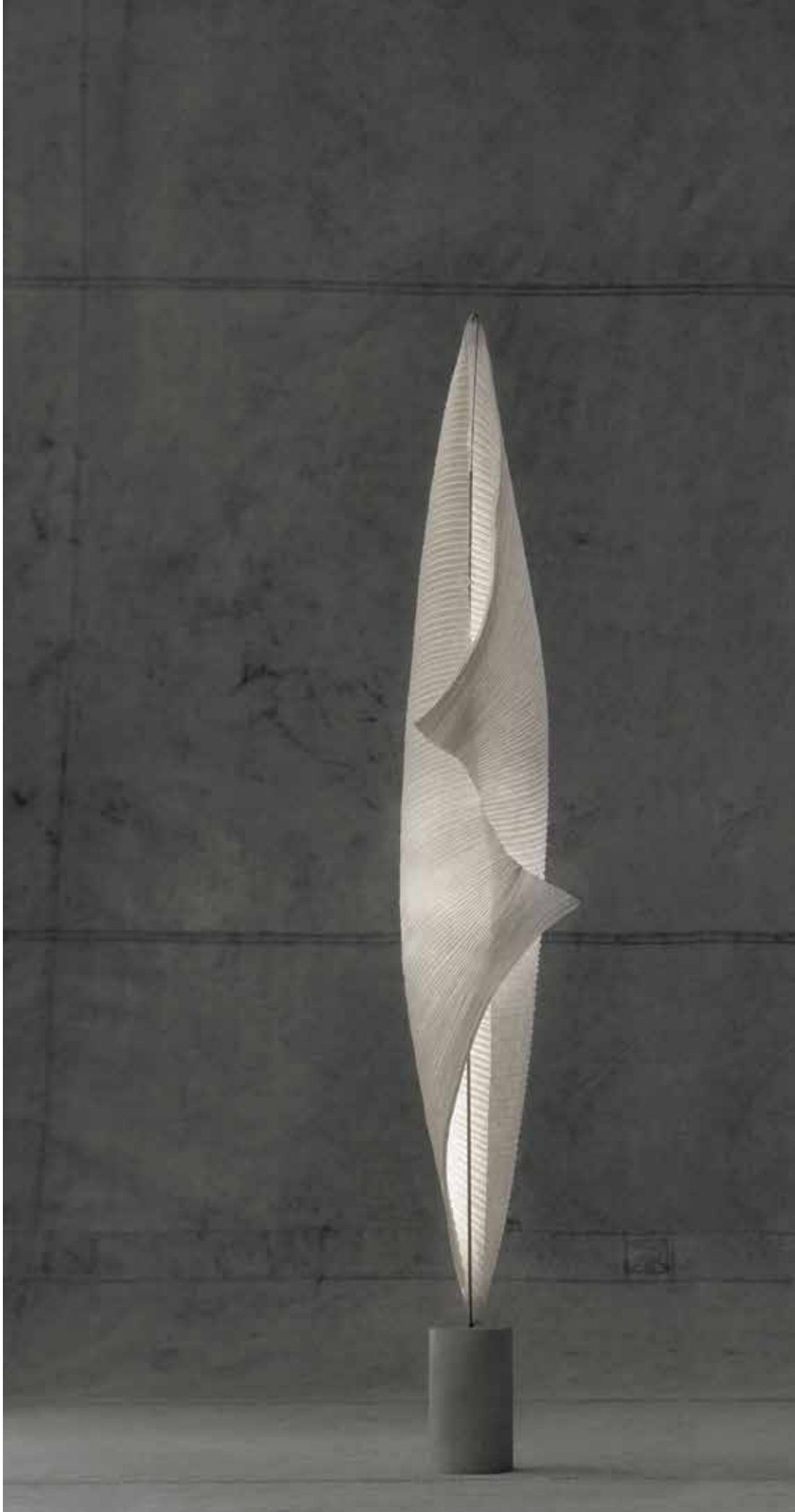

Wo-Tum-Bu family

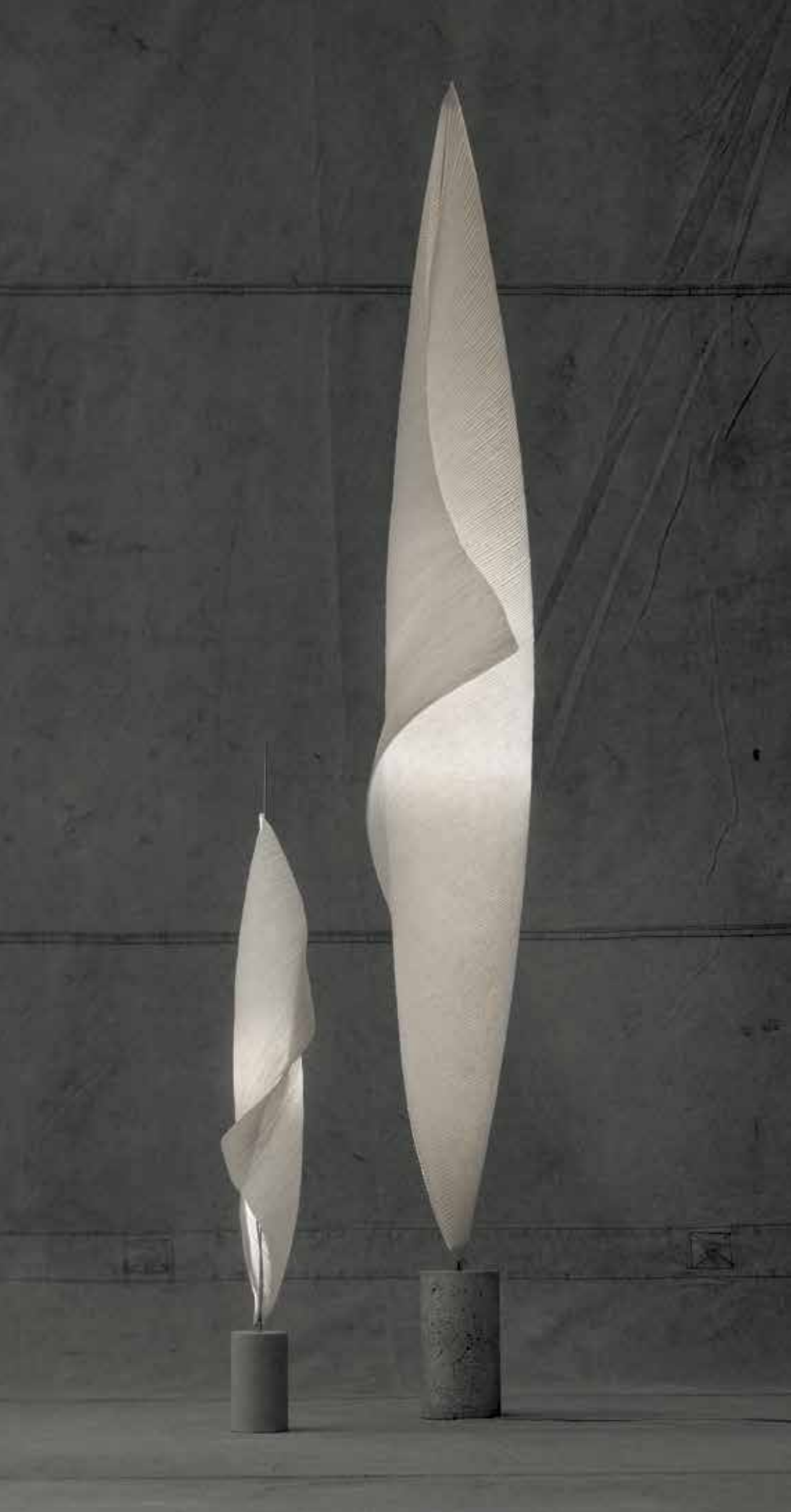

3

1

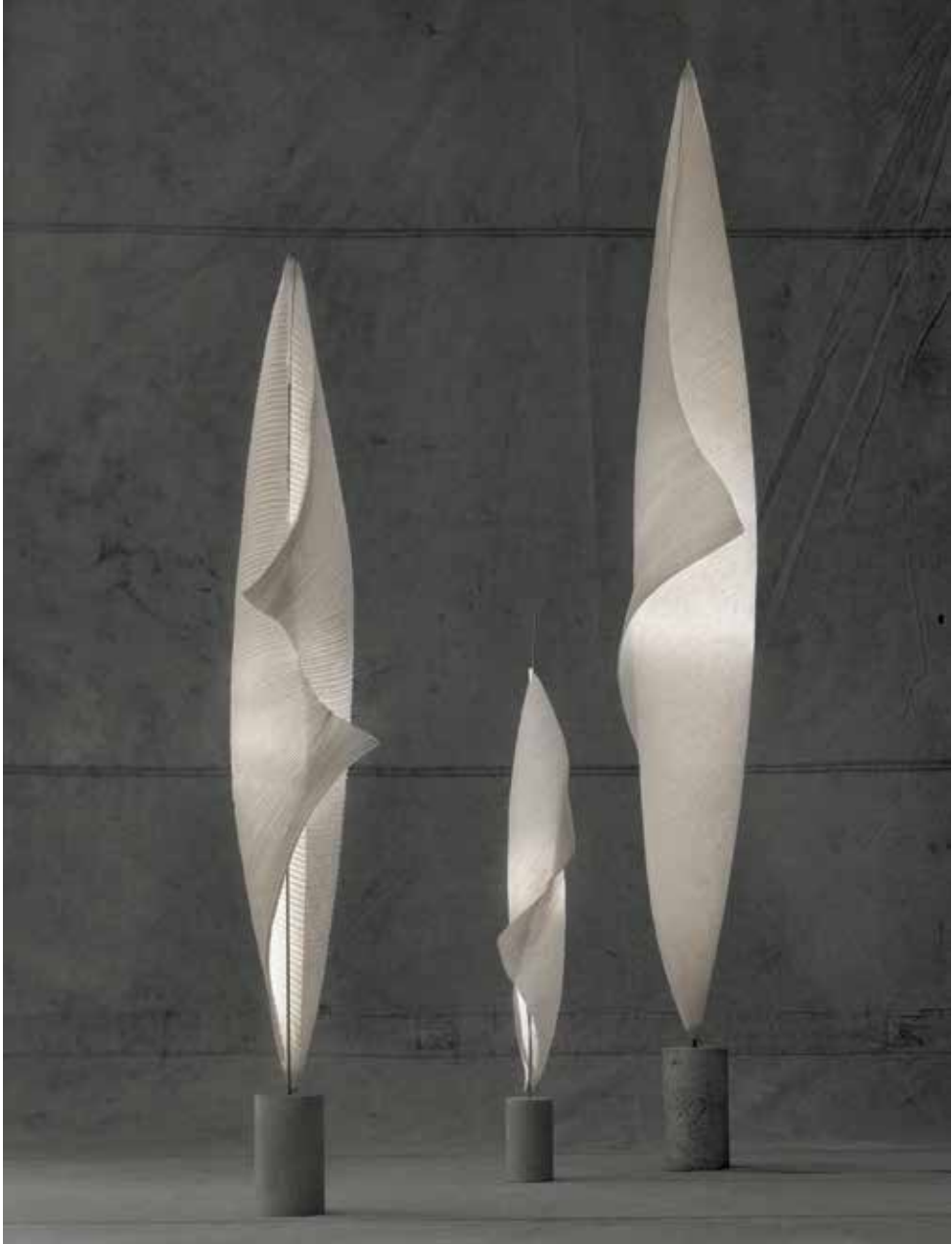

**Wo-Tum-Bu 1** *Dagmar Mombach, Ingo Maurer und Team 1998*

Papier, Beton, Metall, Edelstahl, Kunststoff, Glasfaserblende. Mit Schiebedimmer. Lieferung mit Leuchtmittel. ■ Paper, concrete, metal, stainless steel, plastic, glassfibre shade. Dimmer with slide-control. Complete with bulb. ■ Papier, béton, métal, acier inoxydable, plastique, écran fibre de verre. Avec variateur à curseur. Livrée avec ampoule. ■ Carta, calcestruzzo, metallo, acciaio inossidabile, schermo in vetroresina. Con variatore lineare. Lampadina inclusa.

💡 150 W Halogen, 2870 lm, 2900 K, 2000 h, EEC C 🌀 E27, max. 150 W, A++-E

**Wo-Tum-Bu 2 / Wo-Tum-Bu 3** *Dagmar Mombach, Ingo Maurer und Team 1998*

Papier, Beton, Metall, Edelstahl, Glasfaserblende/Glas. Lieferung mit Leuchtmittel. ■ Paper, concrete, metal, stainless steel, glass-fibre shade/glass. Complete with bulb. ■ Papier, béton, métal, acier inoxydable, écran fibre de verre/verre. Livrée avec ampoule. ■ Carta, calcestruzzo, metallo, acciaio inossidabile, materiale sintetico, schermo in vetroresina. Lampadina inclusa.

💡 50 W Halogen, 910 lm, 3000 K, 2000 h, EEC C 🌀 GY 6,35, max. 50 W, B-E 🖱️ 230/125/12 V



**Con-Qui** *Dagmar Mombach, Ingo Maurer und Team 1998*

Papier, Beton, Metall, Edelstahl, Kohlefaser, Silikon, Glasfaserblende. Lieferung mit Leuchtmittel. ■ Paper, concrete, metal, stainless steel, carbon-fibre, silicone, glassfibre shade. Complete with bulb. ■ Papier, béton, métal, acier inoxydable, fibre de carbone, silicone, écran fibre de verre. Livrée avec ampoule. ■ Carta, calcestruzzo, metallo, acciaio inossidabile, fibra di carbonio, silicone, schermo in vetroresina. Lampadina inclusa.

💡 50 W Halogen, 910 lm, 3000 K, 2000 h, EEC C 🌀 GY 6,35, max. 50 W, B-E 📡 230/125/12 V

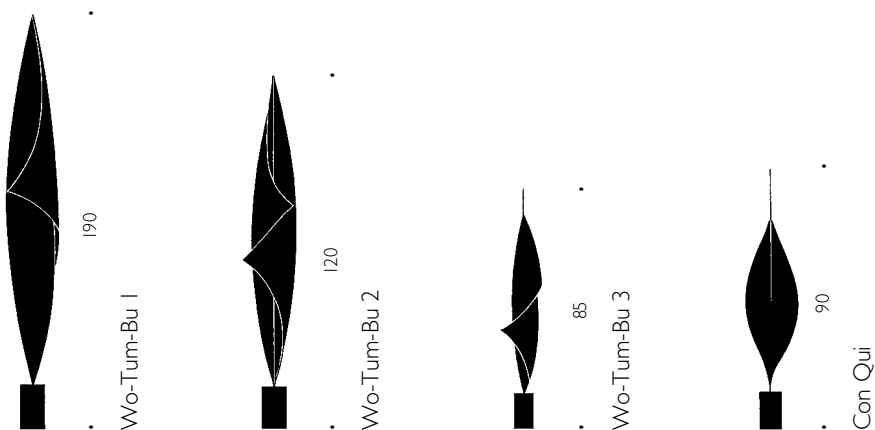

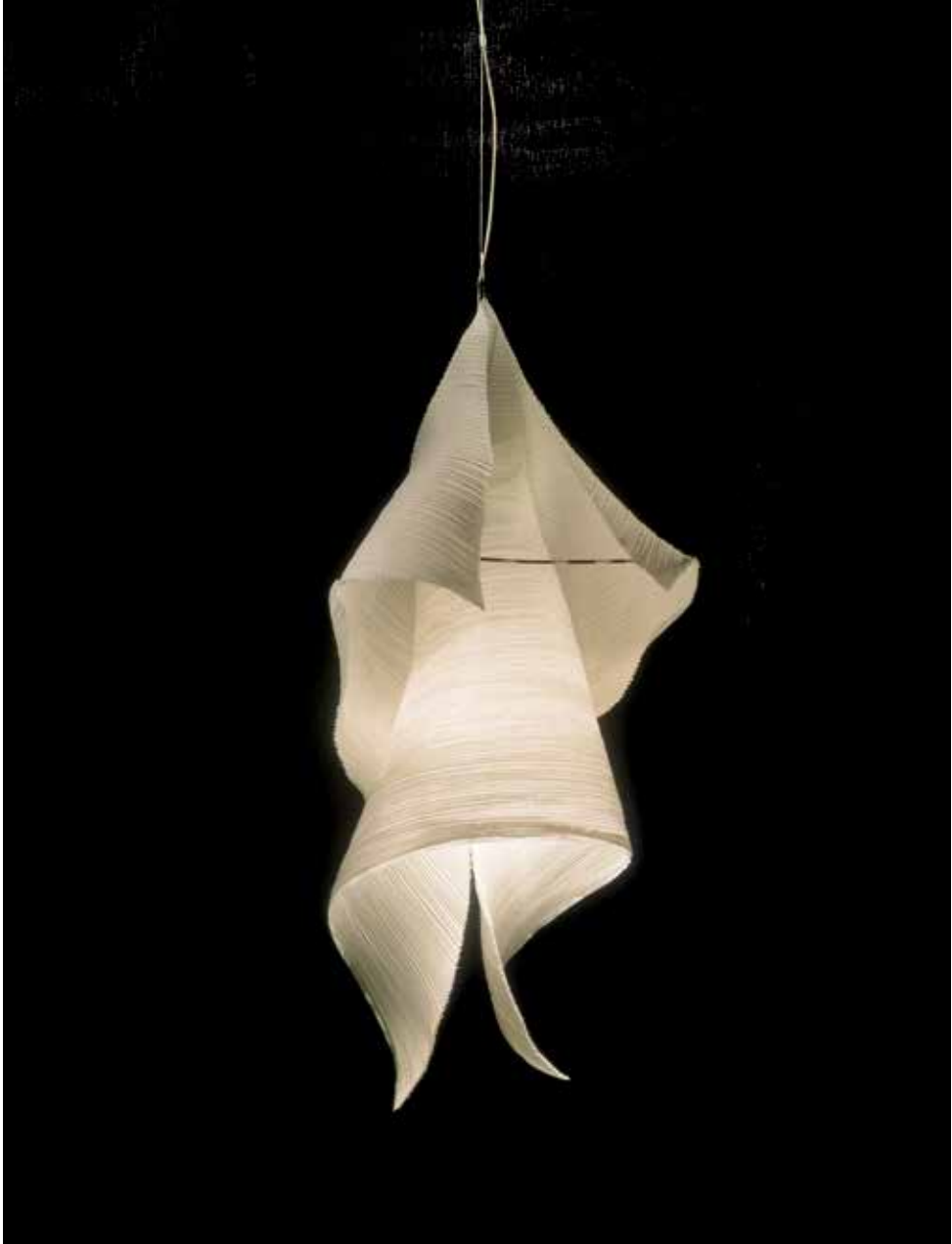

**Jimken** *Dagmar Mombach, Ingo Maurer und Team 1998*

Papier, Metall, Edelstahl, Silikon, Glas. Lieferung mit Leuchtmittel. ■ Paper, metal, stainless steel, silicone, glass. Complete with bulb. ■ Papier, métal, acier inoxydable, silicone, verre. Livrée avec ampoule. ■ Carta, metallo, acciaio inossidabile, silicone, vetro. Lampadina inclusa.



 50 W Halogen, 910 lm, 3000 K, 2000 h, EEC C



 GY 6,35, max. 50 W, B-E  230/125/12 V  300 cm





**Ysmen** Dagmar Mombach, Ingo Maurer und Team 1998

Papier, Metall, Edelstahl, Glas. Lieferung mit Leuchtmittel. ■ Paper, metal, stainless steel, glass. Complete with bulb. ■ Papier, métal, acier inoxydable, verre. Livrée avec ampoule. ■ Carta, metallo, acciaio inossidabile, vetro. Lampadina inclusa.

 50 W Halogen, 910 lm, 3000 K, 2000 h, EEC C  
 GY 6,35, max. 50 W, B-E  230/125/12 V



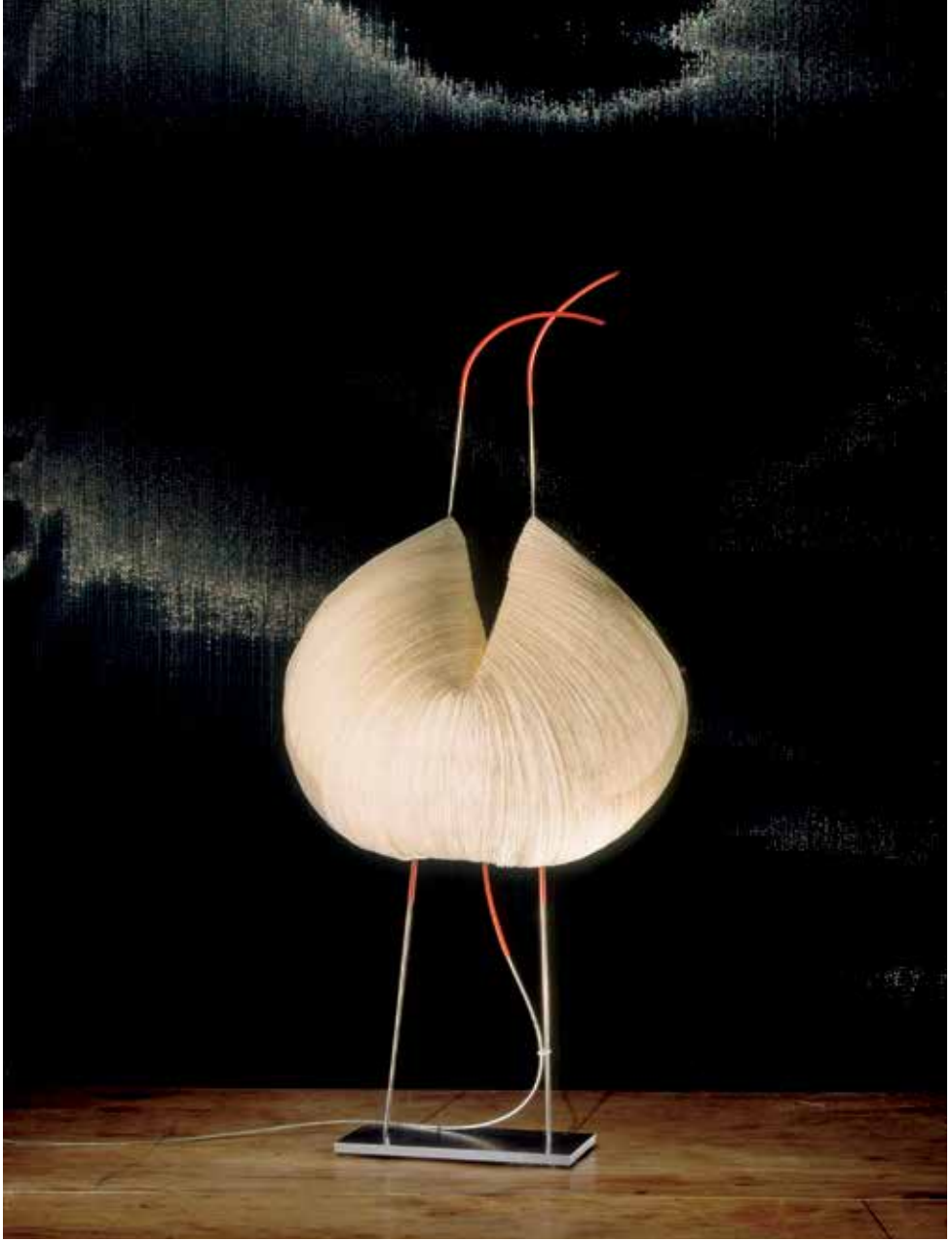

**Poul Poul** *Dagmar Mombach, Ingo Maurer und Team 1998*

Papier, Metall, Edelstahl, Silikon, Glas. Lieferung mit Leuchtmittel. ■ Paper, metal, stainless steel, silicone, glass. Complete with bulb. ■ Papier, métal, acier inoxydable, silicone, verre. Livrée avec ampoule. ■ Carta, metallo, acciaio inossidabile, silicone. Lampadina inclusa.

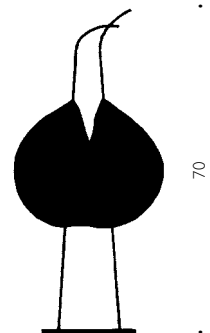

 50 W Halogen, 910 lm, 3000 K, 2000 h, EEC C

 GY 6,35, max. 50 W, B-E  230/125/12 V

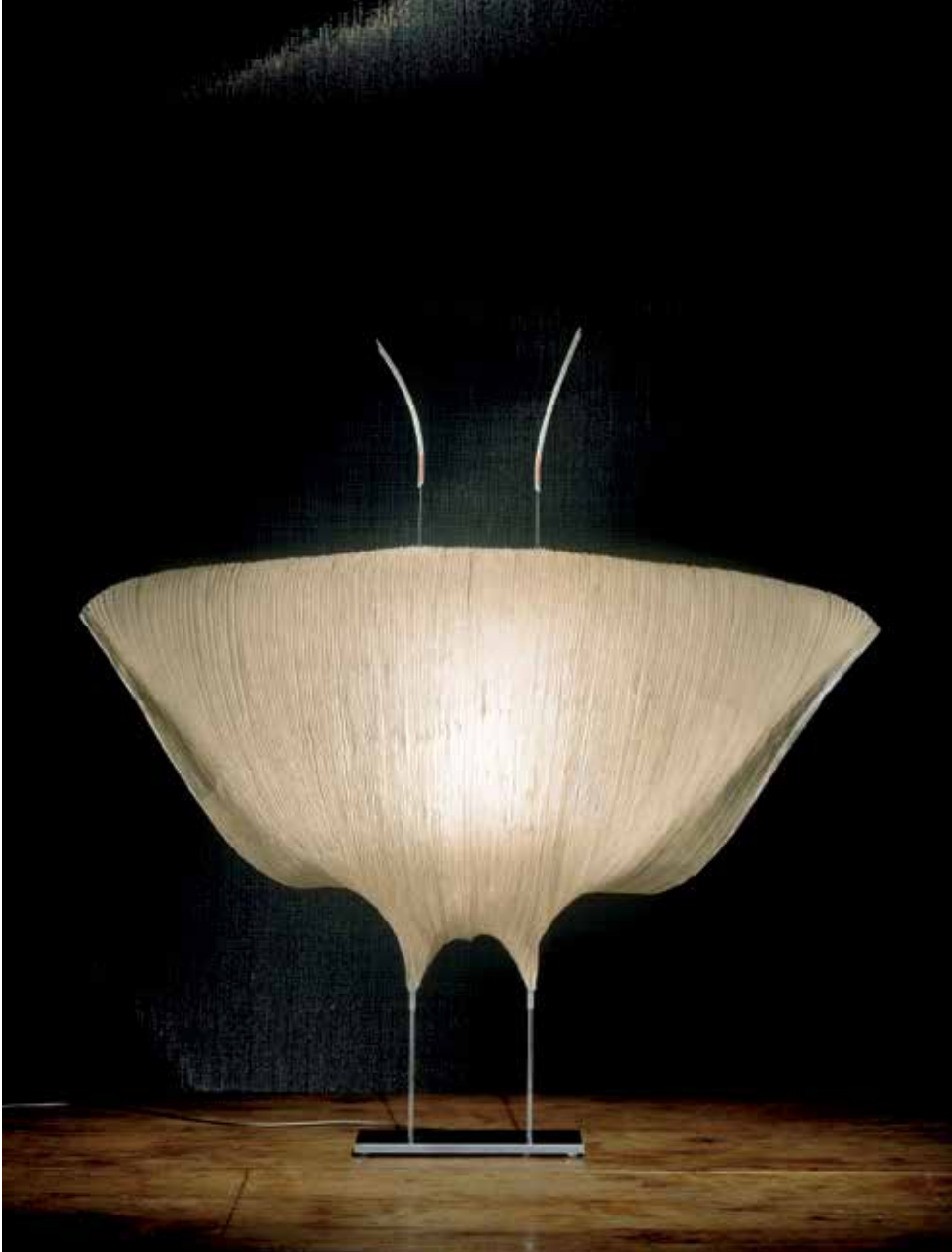

**Samurai** Dagmar Mombach, Ingo Maurer und Team 1998

Papier, Metall, Edelstahl, Silikon, Glas, Glasfaserblenden. Lieferung mit Leuchtmittel.

■ Paper, metal, stainless steel, silicone, glass, glass-fibre shades. Complete with bulb. ■

Papier, métal, acier inoxydable, silicone, verre, écrans fibre de verre. Livrée avec ampoule.

■ Carta, metallo, acciaio inossidabile, silicone, vetro, schermi in vetroresina. Lampadina inclusa.

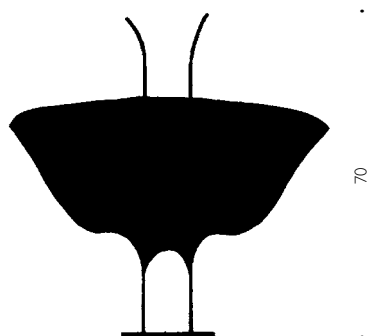

 50 W Halogen, 910 lm, 3000 K, 2000 h, EEC C

 GY 6,35, max. 50 W, B-E  230/125/12 V

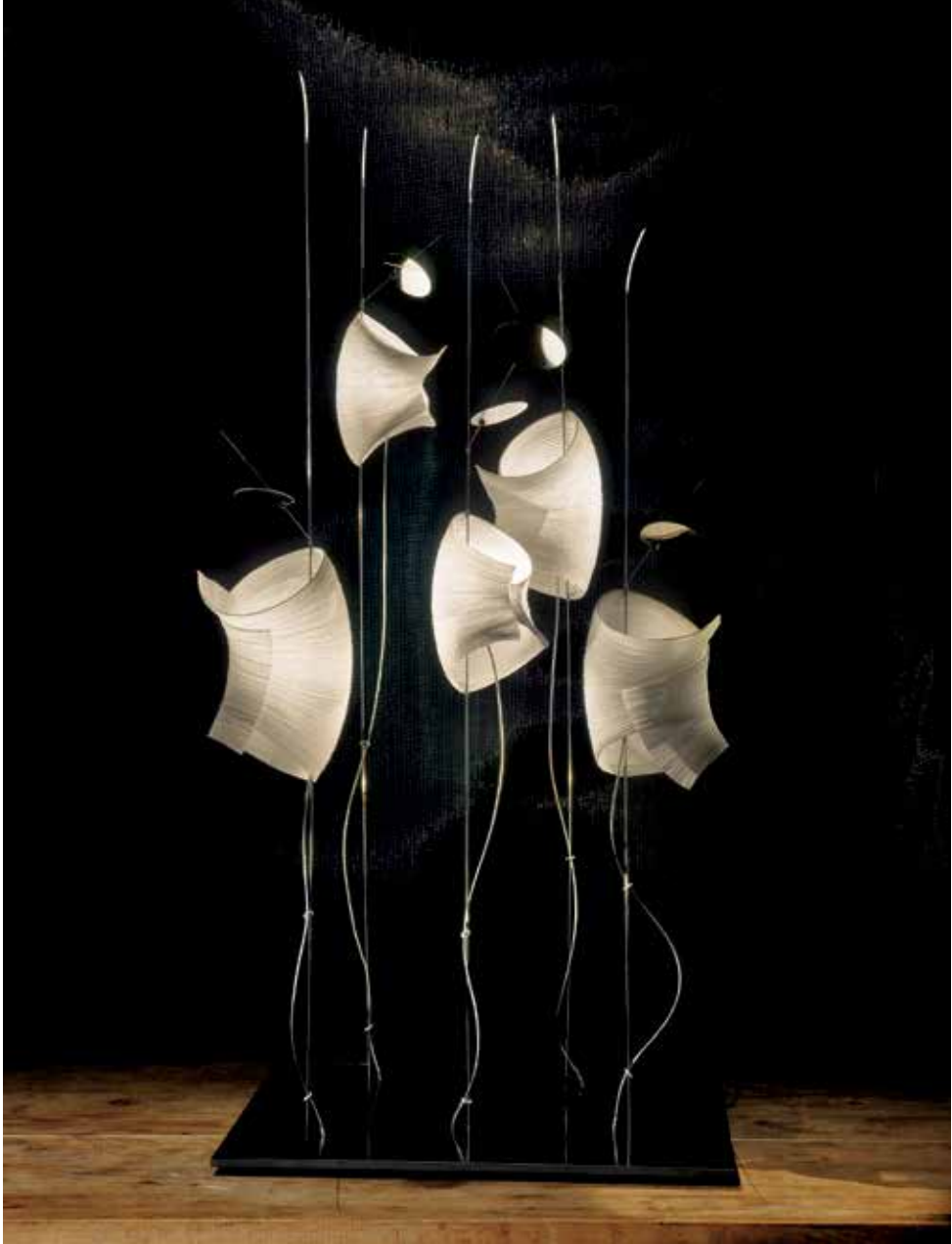

**Mahbruky Dagmar Mombach, Ingo Maurer und Team 1998**

Papier, Metall, Silikon, Glas, Aluminium, verstellbarer Spiegel. 230 Volt: Zwei elektronische Transformatoren, getrennt stufenlos dimmbar. 125 Volt: Transformator ohne Dimmer. Die Position der einzelnen Elemente ist variabel. Lieferung mit Leuchtmitteln. ■ Paper, metal, silicone, glass, aluminium, adjustable mirror: 230 volts: two electronic transformers, separately continuously dimmable. 125 volts: transformer without dimmer. Position of lighting elements is variable. Complete with bulbs. ■ Papier, métal, silicone, verre, aluminium. 230 volts: deux transformateurs électroniques, avec réglage d'intensité lumineuse séparé. 125 volts: transformateur sans réglage d'intensité lumineuse. La position des éléments individuels est variable. Livrée avec ampoules. ■ Carta, metallo, silicone, vetro, alluminio. 230 volt: Due trasformatori elettronici, regolabili separatamente. 125 volt: Trasformatore senza variatore. La posizione degli elementi è variabile. Lampadine incluse.

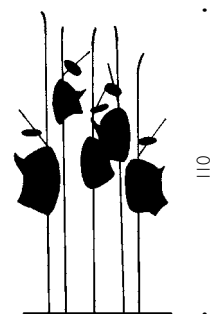

 5 x 35 W Halogen, 910 lm, 3000 K, 2000 h, EEC C

 GY 6,35, max. 50 W, B-E  2 x 230/125/12 V

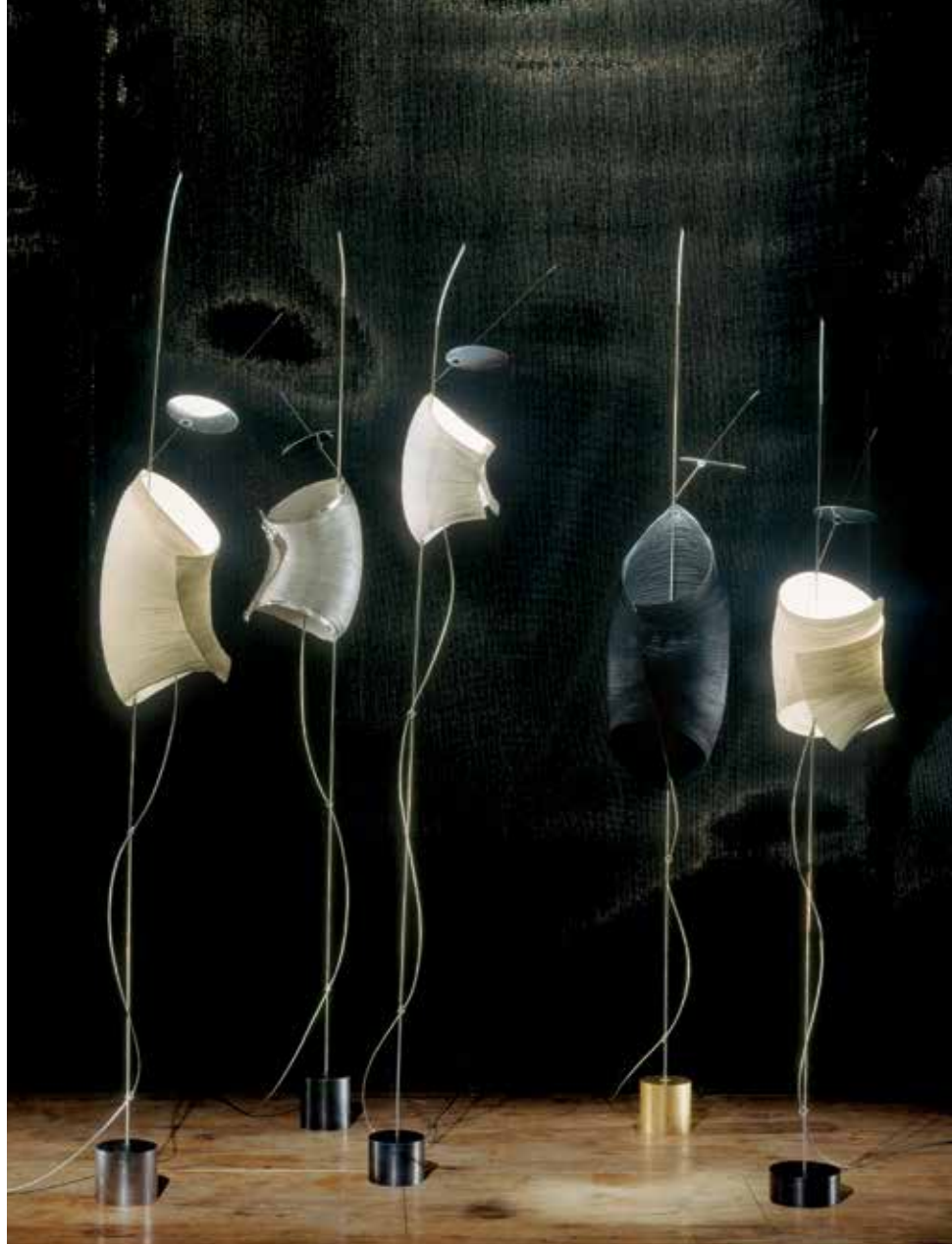

**TheTribe: Watapunga** *Dagmar Mombach, Ingo Maurer und Team 1998*

Fuß in Stahl. Papier nur natur; Metall, Silikon, Glas, Aluminium, verstellbarer Spiegel. Lieferung mit Leuchtmittel. ■ Base in steel. Paper natural only, metal, silicone, glass, aluminium, adjustable mirror. Complete with bulb. ■ Pied en acier. Papier uniquement couleur nature, métal, silicone, verre, aluminium, miroir réglable. Livrée avec ampoule. ■ Base in acciaio. Carta solo di colore naturale, metallo, silicone, vetro, alluminio, specchio regolabile. Lampadina inclusa.

💡 50 W Halogen, 910 lm, 3000 K, 2000 h, EEC C



🔌 GY 6,35, max. 50 W, B-E 📏 230/125/12 V

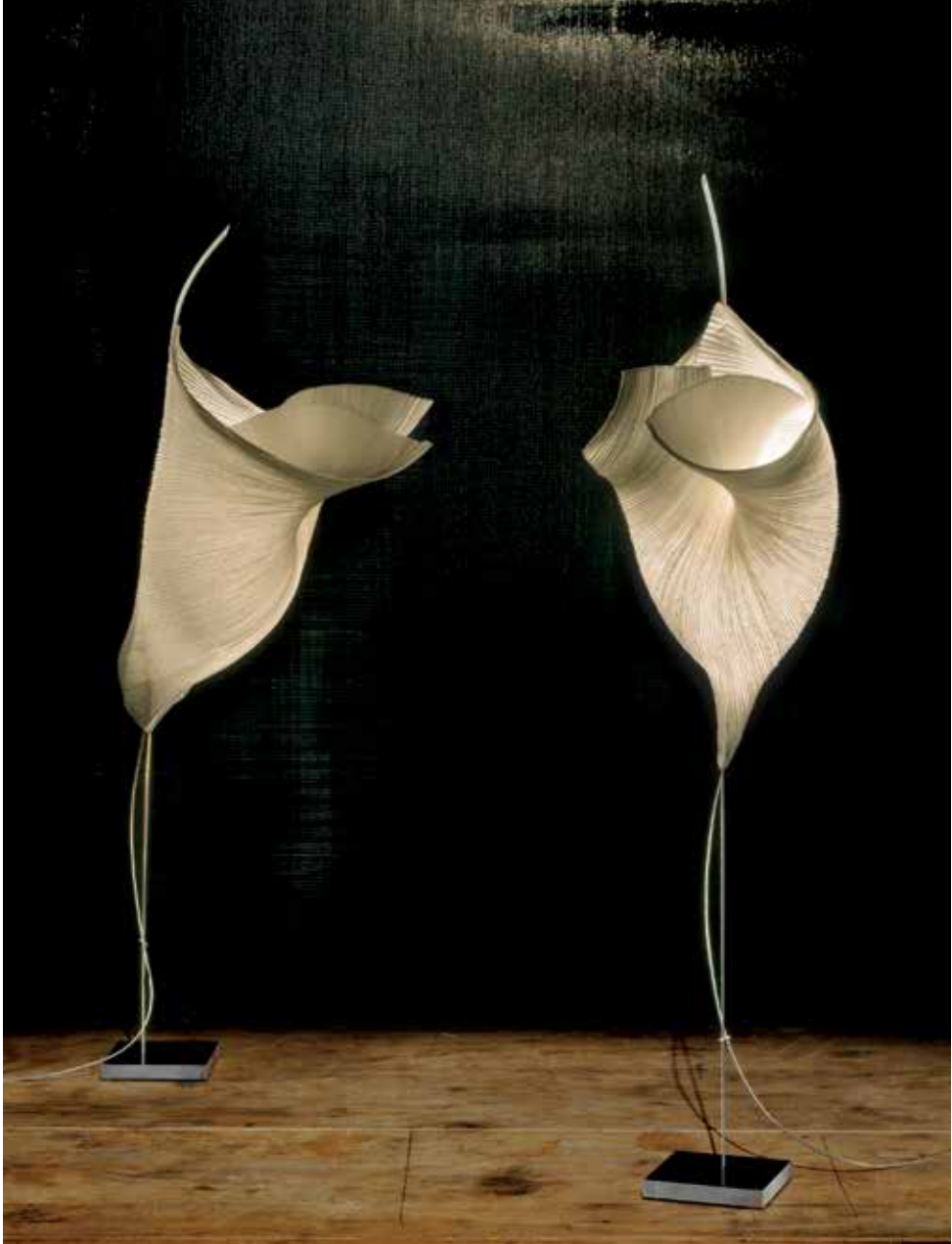



**Gaku** Dagmar Mombach, Ingo Maurer und Team 1998

Papier, Metall, Edelstahl, Silikon, Glas. Lieferung mit Leuchtmittel. ■ Paper, metal, stainless steel, silicone, glass. Complete with bulb. ■ Papier, métal, acier inoxydable, silicone, verre. Livrée avec ampoule. ■ Carta, metallo, acciaio inossidabile, silicone. Lampadina inclusa.

 50 W Halogen, 910 lm, 3000 K, 2000 h, EEC C  
 GY 6,35, max. 50 W, B-E  230/125/12 V



95

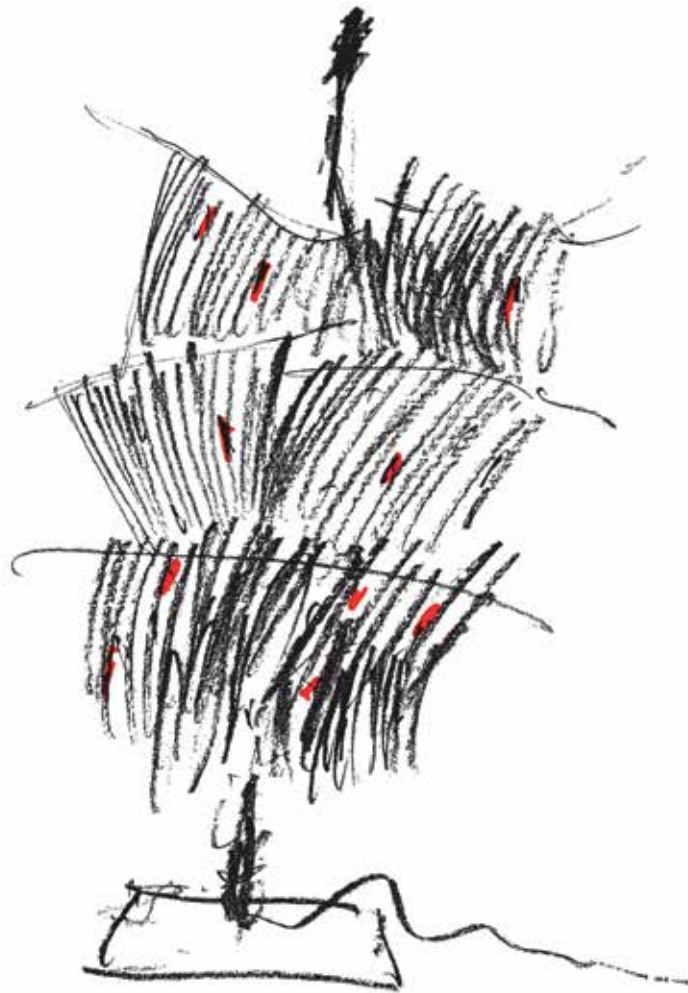

Die MaMo Nouchies sind nicht für Räume mit hoher Luftfeuchtigkeit geeignet. ■ The MaMo Nouchies are not suited for rooms with high humidity. ■ Les MaMo Nouchies ne sont pas appropriées pour des pièces avec un fort taux humidité. ■ I MaMo Nouchies non sono adatti all'uso in ambienti con alta umidità.



**The MaMo Nouchies exhibited at a museum in New York, 2007**









LED +

OLED

+

*specials*



CIRCUIT  
BOARD  
GREEN  
LED



**Bellissima Brutta\***



**Stardust\***



**Licht.Enstein\***

*Thinking of Roy Licht.Enstein!*

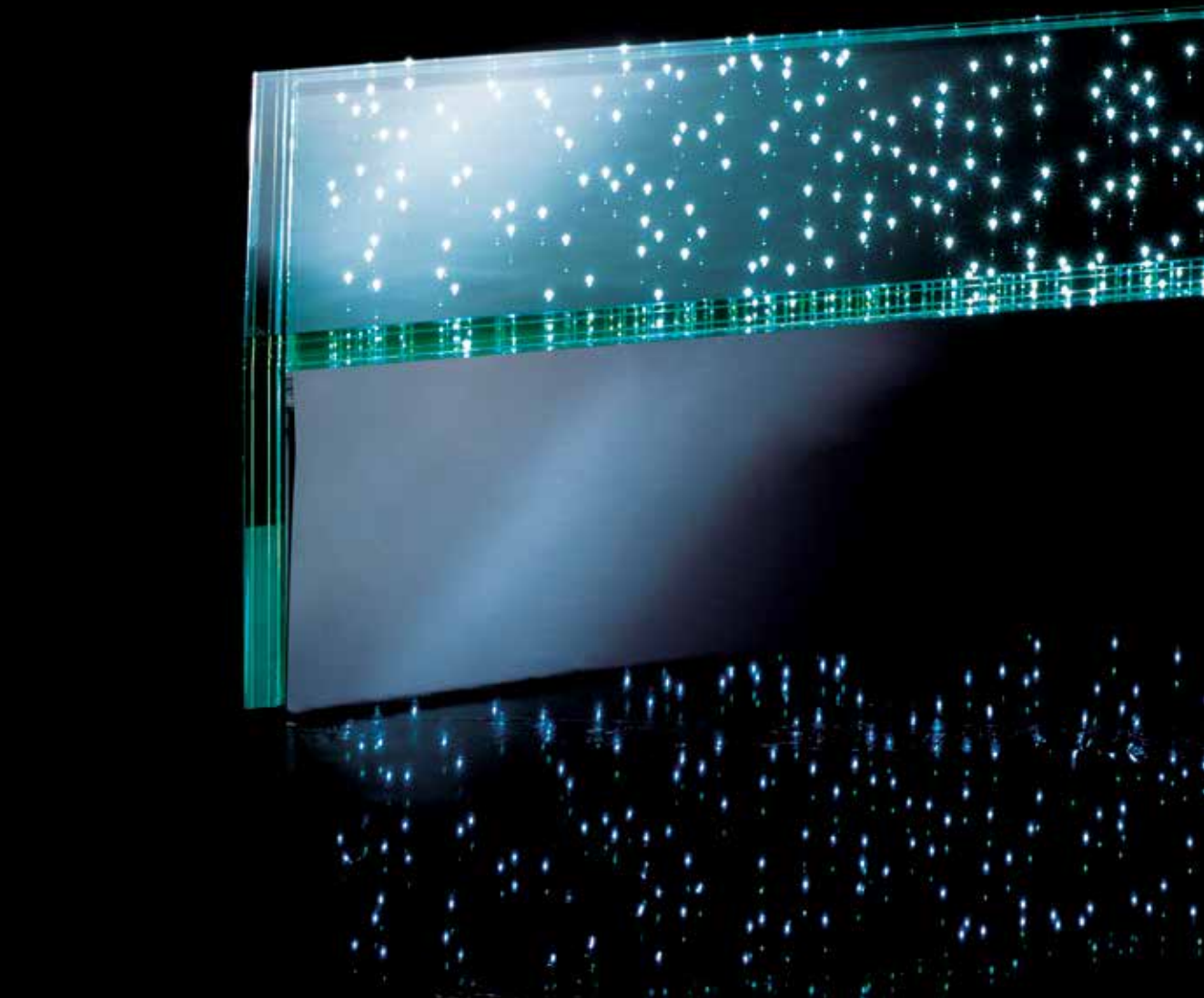

**LED Bench** *Ingo Maurer 2002*

Glas, 288 innen liegende weiße LEDs, beidseitig leuchtend. Dimmbar durch externes Vorschaltgerät. Die LEDs scheinen in der Glasfläche zu schweben, denn keine Leiterbahnen oder Kabel sind sichtbar. Ca. 135 kg. ■ Moulded glass. Within the glass, 288 white LEDs emit light on both sides. Possibility of dimming by use of an external ballast. The LEDs seem to be floating on the glass like magic. No conductors or cables are visible. Ca. 135 kg. ■ Verre. 288 LED blanches à émission lumineuse bilatérale à l'intérieur. Variation de l'intensité lumineuse par un ballast externe. Les LED semblent flotter sur la surface de verre, car ni câble, ni fil électrique ne sont visibles. Env. 135 kg. ■ Vetro. 288 LED bianchi a emissione luminosa bilaterale collocati all'interno. Intensità luminosa regolabile tramite un alimentatore a corrente continua esterno. Non essendo visibili conduttori d'alimentazione o cavi, i LED sembrano galleggiare all'interno del vetro. 135 kg ca.



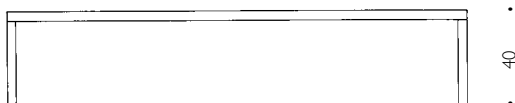

200

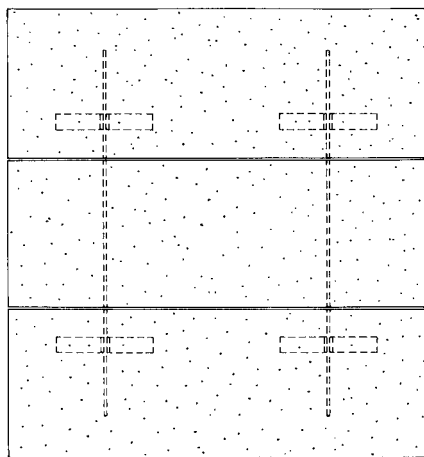
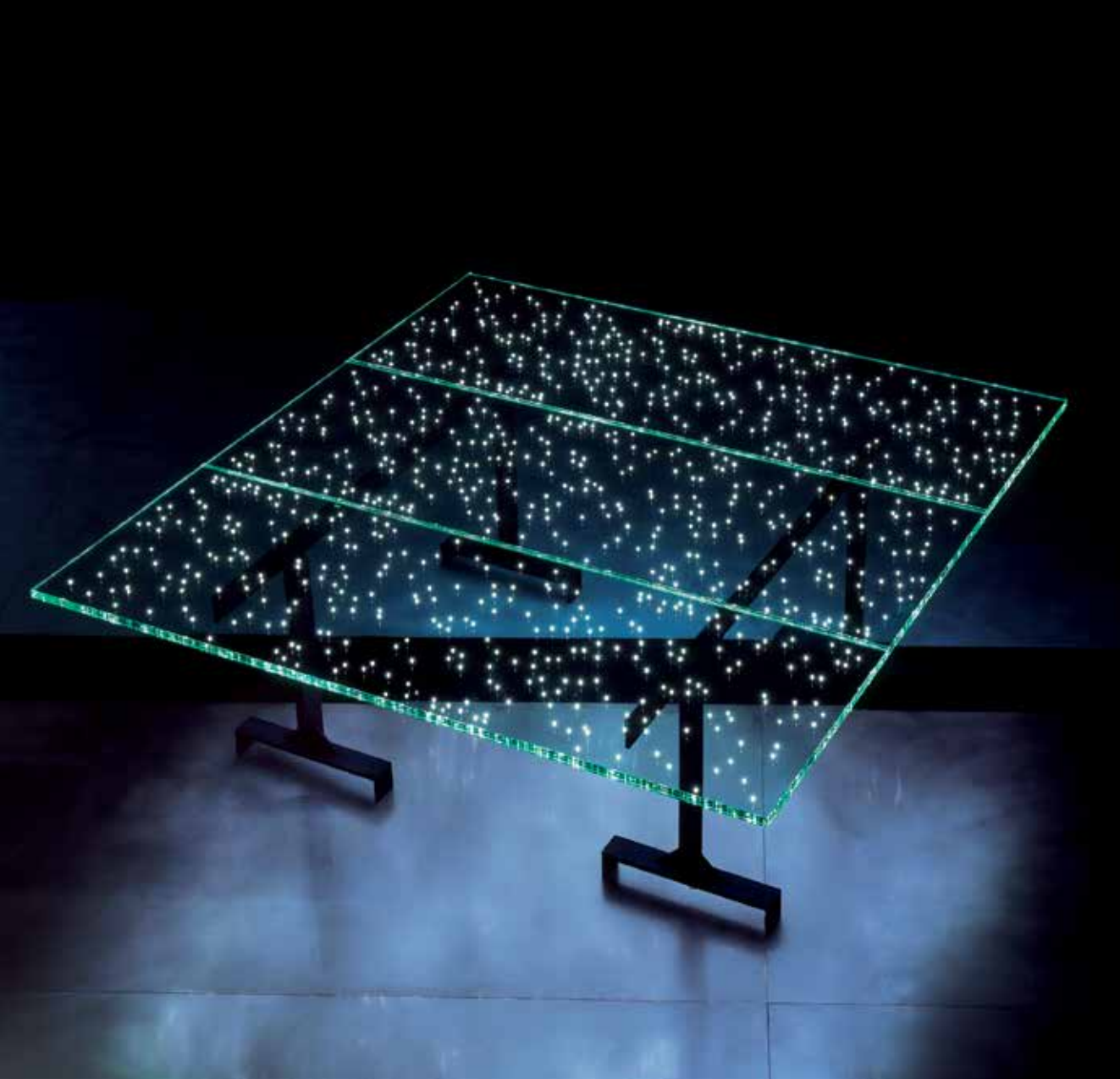

215

75

151

227

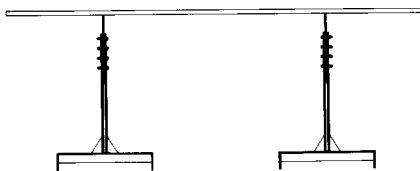

215

ca. 77-92

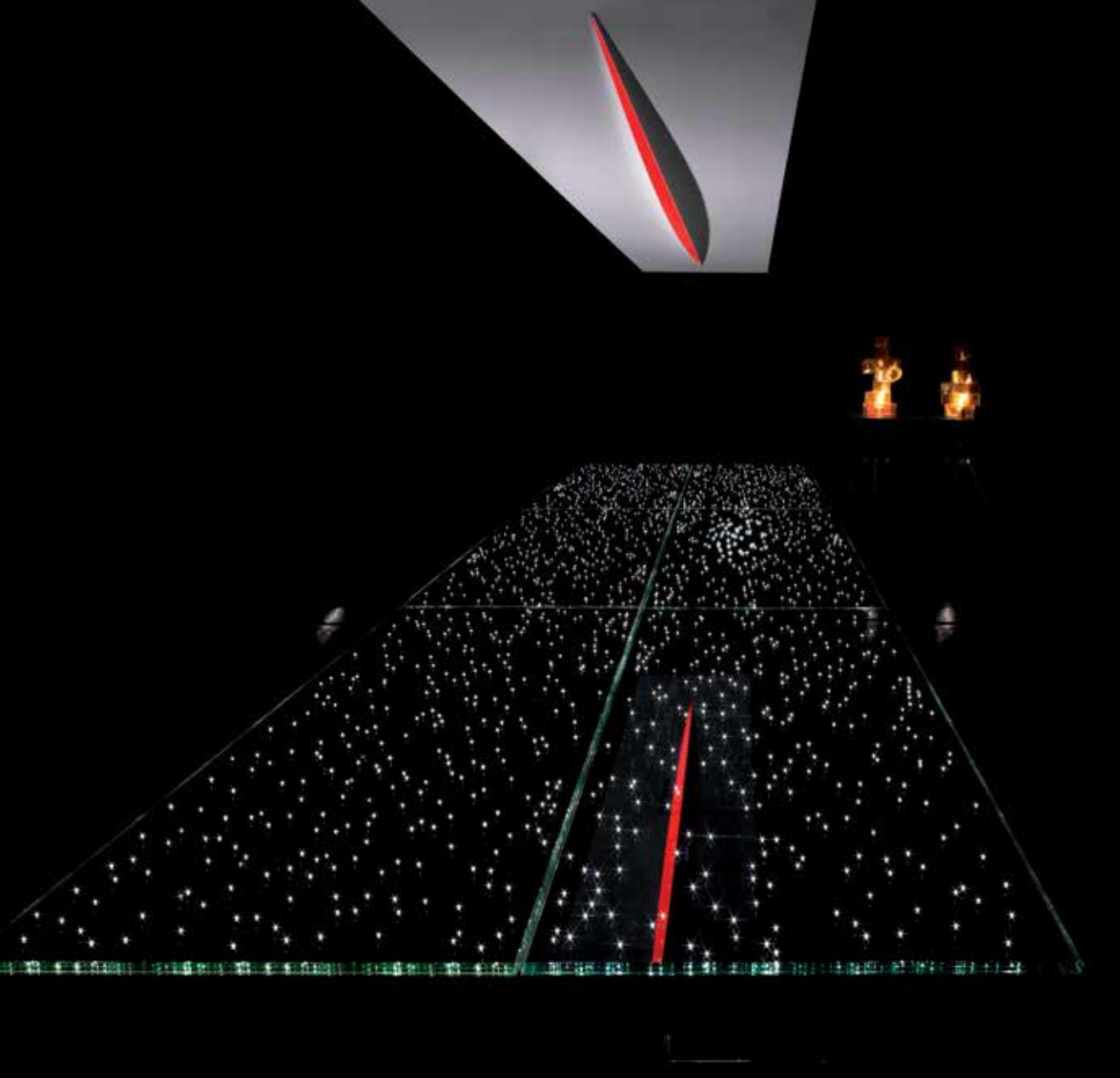

### **LED Table Ingo Maurer 2003**

Sicherheitsglas. Metall. 278 innen liegende weiße LEDs pro Glasplatte, beidseitig leuchtend. Unsichtbare Stromführung. Dimmbar durch externes Vorschaltgerät. Höhenverstellbare Metallgestelle. Lieferbar mit 1, 2 oder 3 Glasplatten. Gewichte: mit 2 Glasplatten ca. 360 kg, mit 3 Glasplatten ca. 500 kg. ■ Laminated safety glass, metal. 278 white LEDs per table top inside, emitting light on both sides. Invisible live parts. Possibility of dimming by use of an external ballast. Metal bases adjustable in height. Available with 1, 2 or 3 table tops. Weights: with 2 table tops approx. 360 kg, with 3 table tops approx. 500 kg. ■ Verre feuilleté, métal. 278 LEDs blanches à émission lumineuse bilatérale à l'intérieur d'un plateau. Conduction invisible du courant. Variation de l'intensité lumineuse par un ballast externe. Supports métalliques réglables en hauteur. Livrable avec 1, 2 ou 3 plateaux en verre. Poids: avec 2 plateaux env. 360 kg, avec 3 plateaux env. 500 kg. ■ Vetro temperato, metallo, 278 LEDs bianchi a emissione luminosa bilaterale collocati all'interno di ogni lastra. Conduttori elettrici tra i LED invisibili. Intensità luminosa regolabile tramite un alimentatore a corrente continua esterno. Con piedi in metallo regolabili in altezza. Disponibile con 1, 2 o 3 lastre. Pesi complessivi: con 2 lastre ca. 360 kg., con tre lastre ca. 500 kg.



278 LEDs per table top in white, red or blue, external transformer 230/125/48 V DC



**Lüster** Ingo Maurer 2003

Bedrucktes Glas. 287 innen liegende weiße LEDs, beidseitig leuchtend. Dimmbar durch externes Vorschaltgerät. Keine Leiterbahnen oder Kabel sind sichtbar, die Abhängeseile versorgen den Lüster mit Strom. ■ Imprinted moulded glass. Within the glass, 287 white LEDs emit light on both sides. Possibility of dimming by use of an external ballast. No conductors or cables are visible. The suspension wires transport electricity to the chandelier. ■ Verre imprimé. 287 LED blanches à émission lumineuse bilatérale. Variation de l'intensité lumineuse par un ballast externe. Aucun fil et câble électrique ne sont visibles, les fils de suspension alimentent le lustre en courant. ■ Vetro stampato. 287 LED bianchi a emissione luminosa bilaterale collocati all'interno. Intensità luminosa regolabile tramite un alimentatore a corrente continua esterno. Non sono visibili conduttori d'alimentazione o cavi; il lampadario è alimentato da cavi di sospensione.

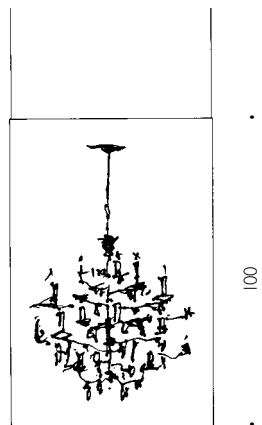

65

**EL.E.DEE** Ingo Maurer 2001

EL.E.Dee, our first LED task lamp, is sold out. An avantgarde design of 2001, now a collector's item.

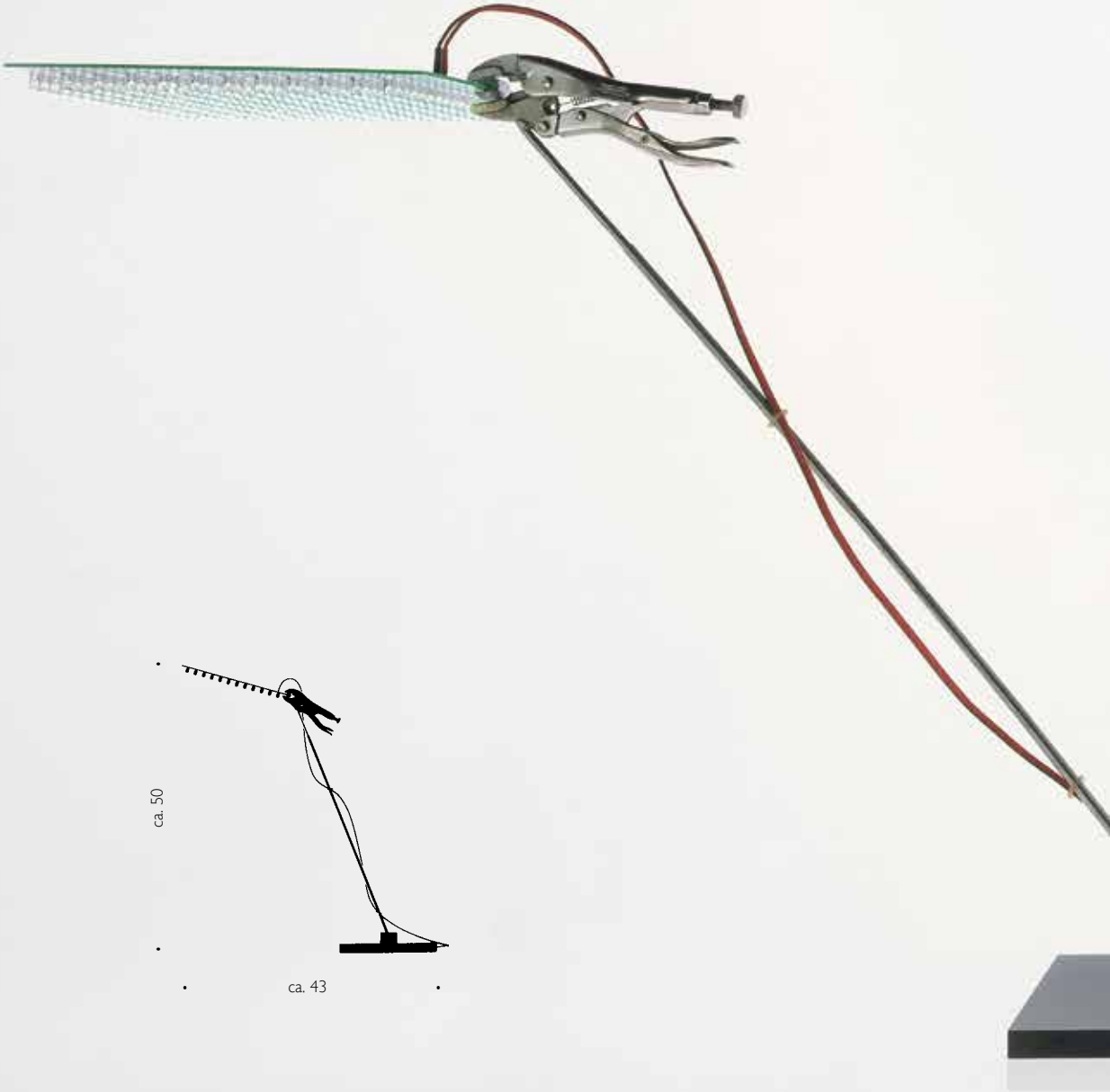

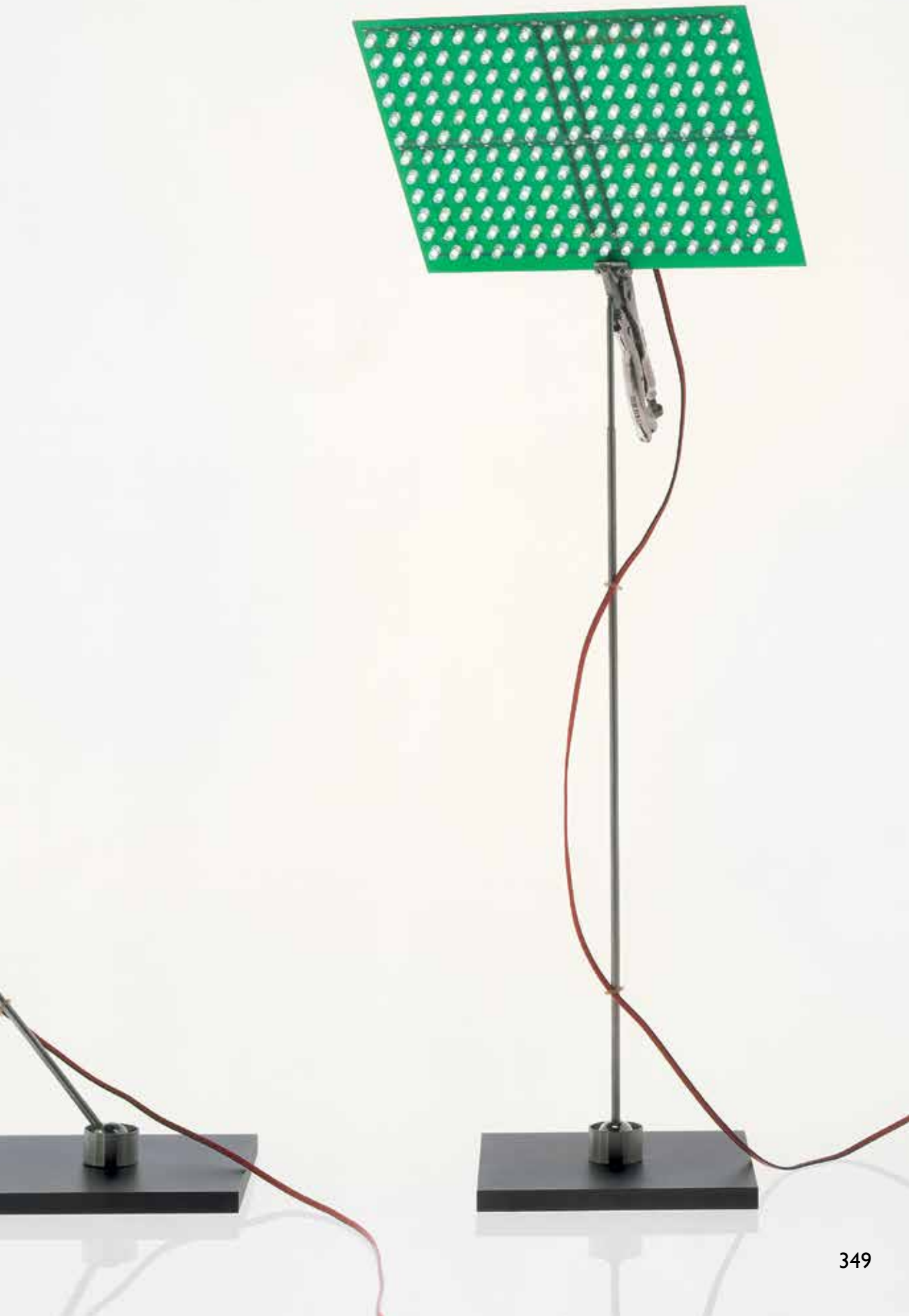



\* Limited production, Gestaltung: Ingo Maurer 2006



**One Thousand and One Lights\***





\* Limited production, Gestaltung: Ingo Maurer 2007



**LED Paravent\***



**1001 Lights, LED Paravent, and Rose Rose on the Wall** are majestic objects custom-made from circuit boards with LEDs. They are a seduction to dream on and let yourself be taken to another uncharted world. Colour and radiance can be adjusted to suit your mood.



**Rose, Rose on the Wall ...\***



\* Limited production, Gestaltung: Ingo Maurer 2006

# First LED wallpaper 2011. Colour



**and brightness adjustable.**



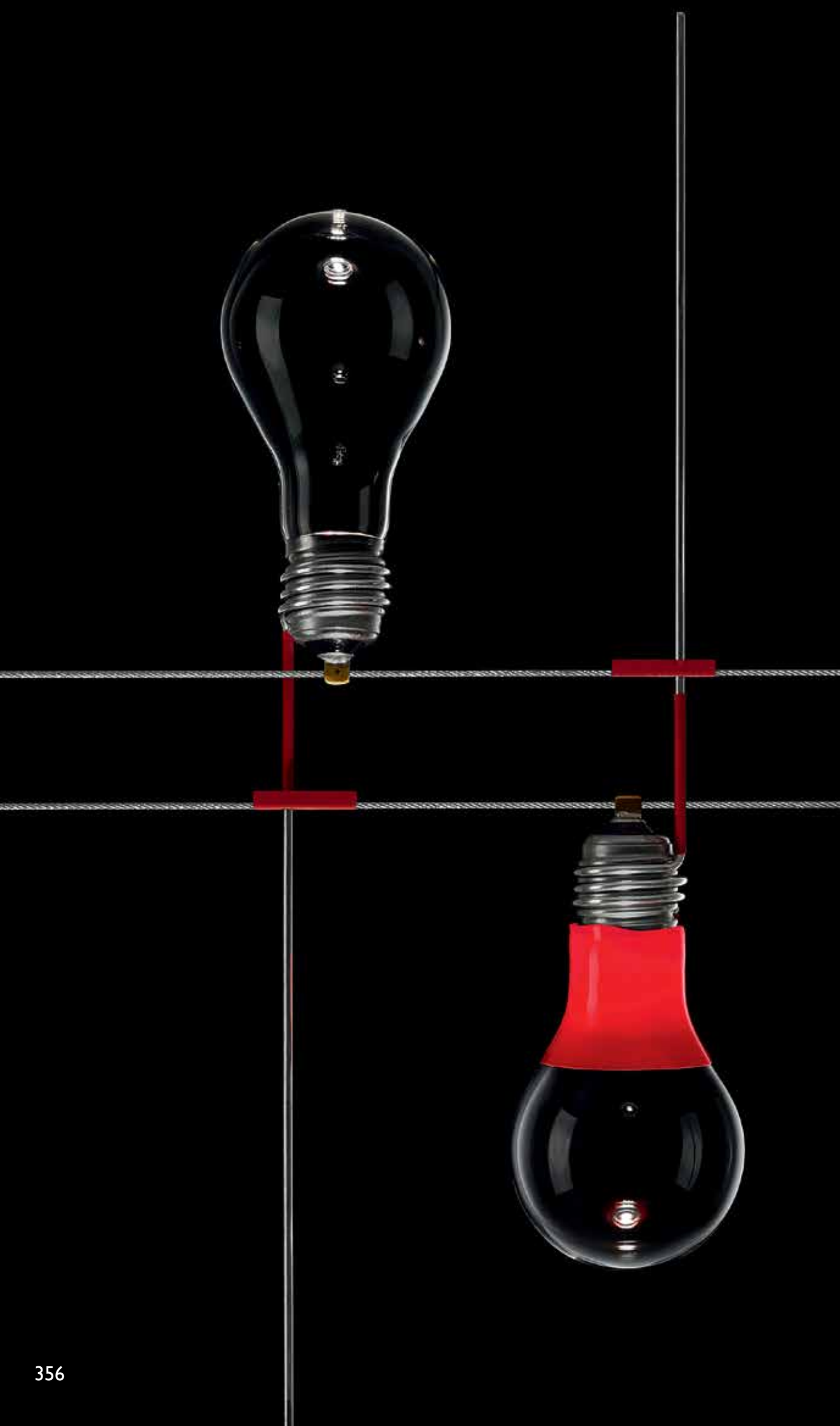

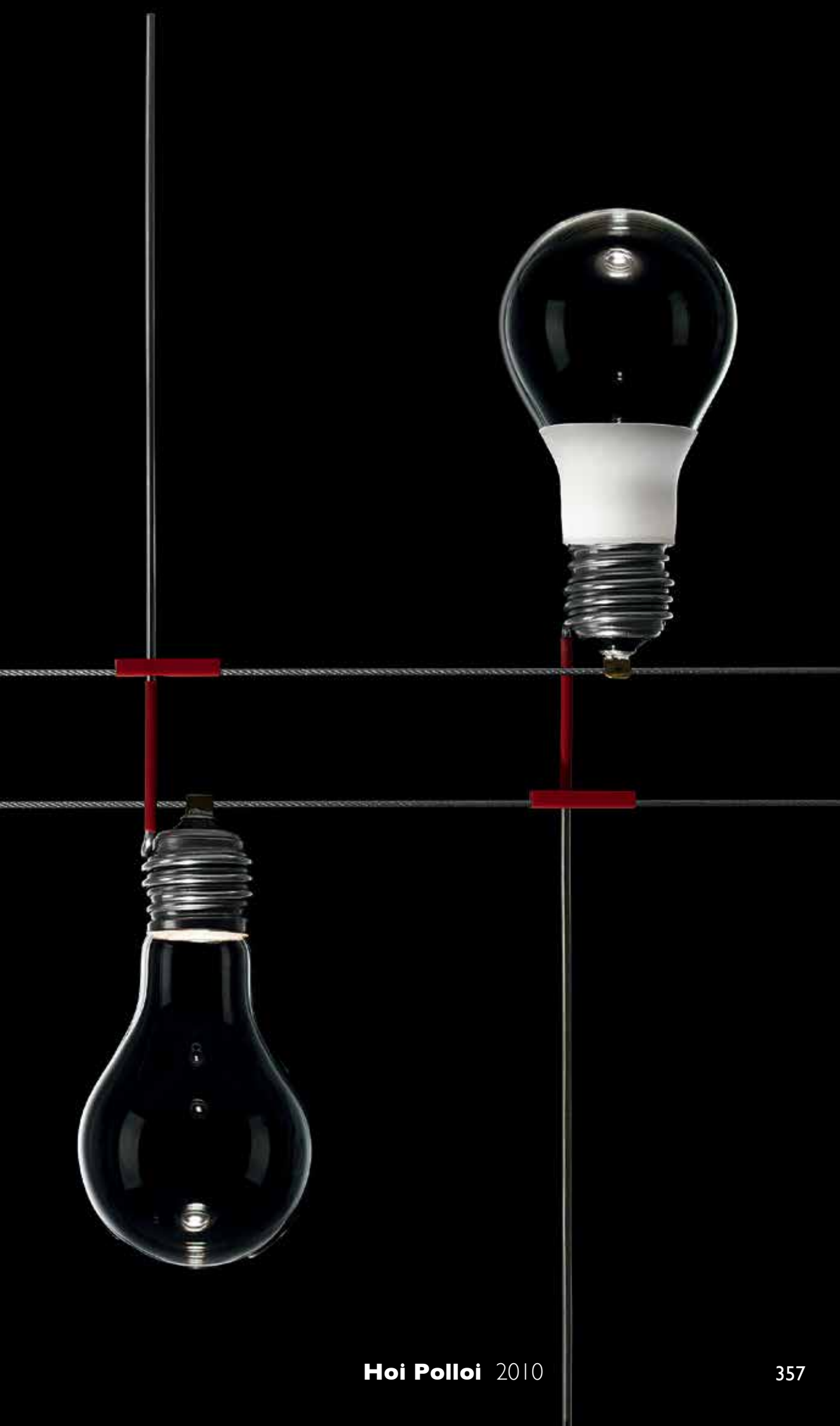

**OH•LED•ONE** Ingo Maurer 2015

Glas, Edelstahl, Kunststoff. Oled Modul von LG Chem. Die Neigung der Lampe lässt sich über das Kugelgelenk am Fuß stufenlos einstellen. ■ Glass, stainless steel, plastic. OLED module by LG Chem. The angle of the lamp is freely adjustable by the ball-and-socket joint in the base. ■ Verre, acier inoxydable, matière plastique. Module OLED de LG Chem. L'inclinaison de la lampe est réglable sans graduation par l'articulation à rotule au niveau du socle. ■ Vetro, acciaio inossidabile, materiale sintetico. Modulo OLED di LG Chem. L'inclinazione della lampada può essere regolata mediante un giunto a sfera.

 7 W OLED, 500 lm, 3000 K, CRI 90  230/125/22 V









25 flexible organic  
LED panels,  
fixed with magnets  
on a branch  
made of metal.  
A collaboration  
of Ingo Maurer  
and Team with  
the meticulous  
engineers of  
Konica Minolta,  
Japan.

An inspiring One-Off.





### **Early Future** Ingo Maurer 2008

Limitierte Auflage. Metall, Glas, 10 OLED Module von OSRAM Opto Semiconductors. Externes elektronisches Vorschaltgerät. ■ Limited edition. Metal, glass, 10 OLED modules by OSRAM Opto Semiconductors. External electronic ballast. ■ Édition limitée. Métal, verre, 10 modules OLED de OSRAM Opto Semiconductors. ■ Edizione limitata. Metallo, vetro, 10 moduli OLED di OSRAM Opto Semiconductors. Con alimentatore a corrente continua esterno.



One Off, 2006

## Flying Future





**Double C. Future\*** Ingo Maurer 2010

A combination of OLED modules and LEDs, wired for separate switching. The LED spots can be adjusted flexibly via cardan joints. Suspension on four live wires.



**Double T. Future\*** *Ingo Maurer 2010*

OLED and LED spots, wired for separate switching, as in the suspension version.  
The angle of the lamp head is freely adjustable via ball-joint.



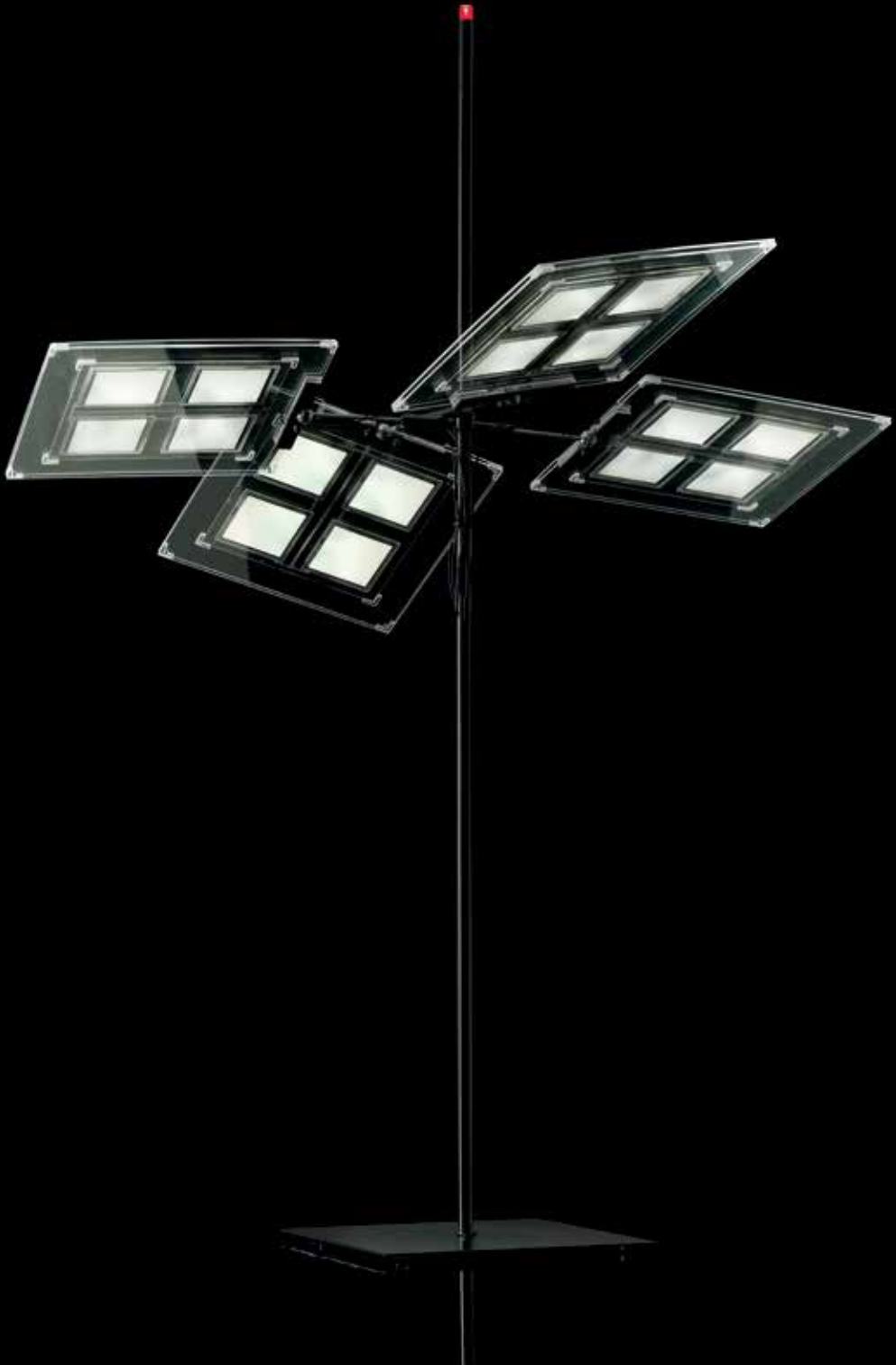

**4 x 4 is 34** *Ingo Maurer 2010*

Four transparent OLED modules on glass plates. 4 x 4 is 34 is a One-Off experimental object.



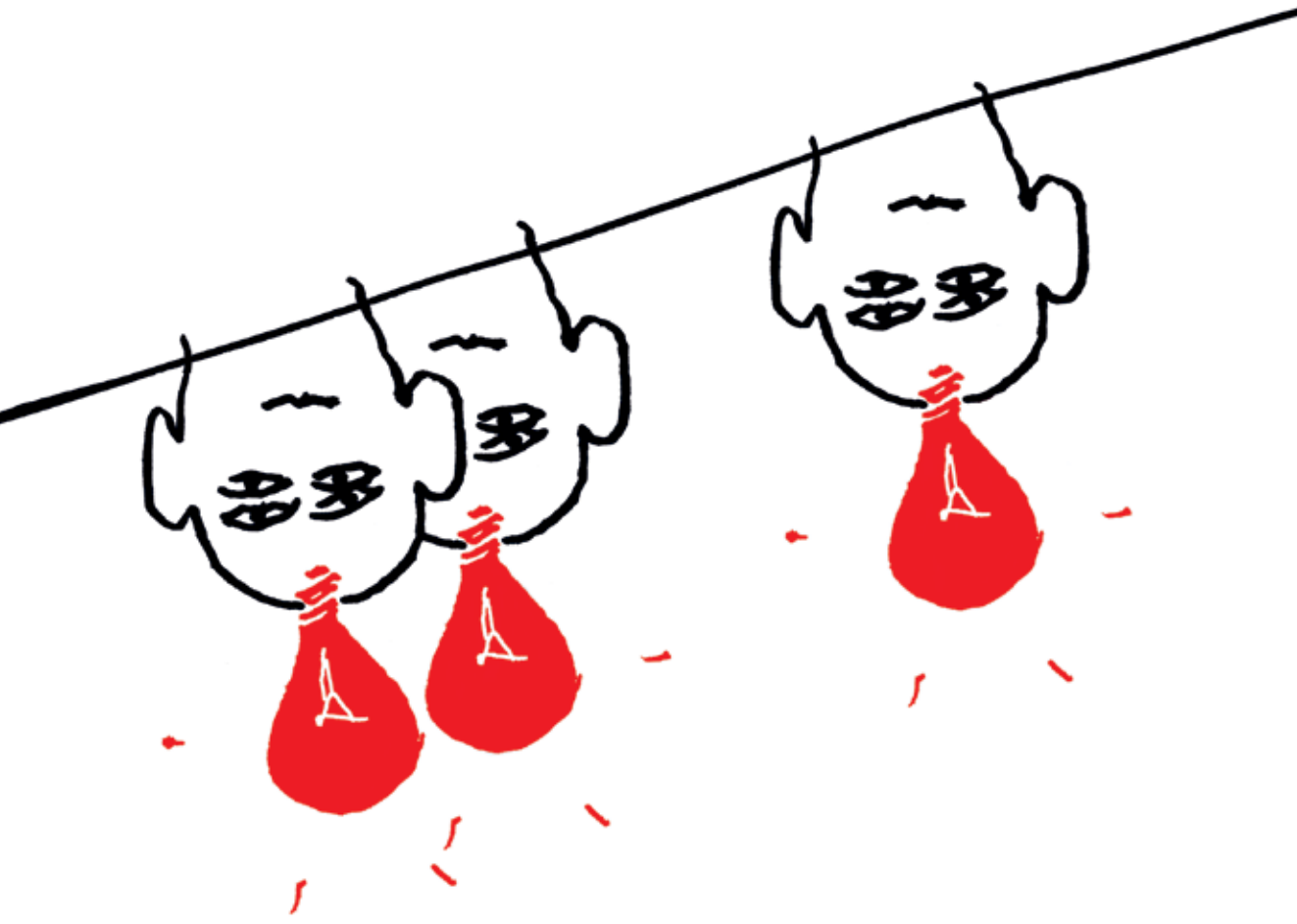

**Yá Yá Ho**

Die Idee für YaYaHo (1984) kam wie ein Blitz aus heiterem Himmel: Am frühen Neujahrmorgen des Jahres 1980 sah Ingo Maurer auf Haiti Glühlampen, die direkt mit den Stromkabeln verlötet waren und die Straßen für das Fest beleuchteten. Nach vier Jahren harter Entwicklungsarbeit war das System aus Niedervolt-Halogenreflektoren, die von straff gespannten Kabeln abgehängt werden, perfektioniert – ein Kraftaufwand, der seine Firma beinahe in den Bankrott geführt hätte. Gleichzeitig entwickelte ein Schweizer Designer, Hannes Wettstein, ein ähnliches Konzept, das ebenso wie YaYaHo häufig kopiert wurde.

Aber allen Plagiaten fehlt die Präzision und die detaillierte Ausarbeitung des aus 276 Teilen bestehenden Systems. YaYaHo ermöglicht seinen Anwendern, Höhe und Platzierung jedes Elements zu variieren und die Reflektionen mit kleinen, beweglichen Spiegeln anzupassen. „Ich möchte, dass meine Entwürfe etwas Unfertiges an sich haben, um den Menschen, die sie benutzen, Raum für ihren eigenen gestalterischen Beitrag zu lassen.“ Der Designkritiker Deyan Sudjic fand, dass YaYaHo mit seinem schillernden Funkeln, das an das Geflacker von Kerzen erinnert, „einen subversiven Angriff auf die oberflächliche mechanische Perfektion darstellt, die für die so genannten modernen Leuchten charakteristisch ist“.

The idea for YaYaHo (1984) came in a flash, following a New Year's celebration in Haiti, where Maurer saw how locals solder lightbulbs onto overhead power cords to illuminate street fairs. It took four years to perfect the system of suspending halogen reflectors from tautly strung low-voltage cables, and the effort almost bankrupted his company. Contemporaneous to his research, another designer, Hannes Wettstein, developed a similar concept and both were widely plagiarized.

However, the rip-offs lack the precision and artistry of the 276-part system. YaYaHo allows the user to adjust the height and placement of each suspended element as well as the tiny mirrors that bounce the light. "I want things to look unfinished, and to leave space for the people who use or look at them to add something of themselves," says Maurer. Critic Deyan Sudjic thought that YaYaHo "subverts the glossy mechanical perfection that characterizes so-called modern lighting," providing a sparkle and dazzle that take one back to the flutter of candlelight.

Michael Webb, 2003



**Ya Ya Ho** Ingo Maurer und Team 1984

**Ya Ya Ho** ist ein Niedervolt-Lichtsystem und wird über einen Transformator (Leistung max. 200 Watt) betrieben, der 230/125 Volt auf 12 Volt reduziert. Alle Elemente sind horizontal und einige zusätzlich auch vertikal beweglich. Lieferung mit Leuchtmittel, Bohr-schablone und Spannwerkzeug. Jedes Part und jedes Element ist auch einzeln lieferbar. Montagehöhe: 230–250 cm. Belastbarkeit der Seile 350 Watt. Spannlänge ohne Decken-abhängung: 10 Meter. Sonderanfertigung und Planung auf Anfrage möglich. **Ya Ya Ho** is a low-voltage lighting system fed by a transformer (max. capacity 200 watts) which reduces the 230/125 volt mains current to 12 volts. All elements are adjustable – hori-zontally, and in some cases vertically, too. Complete with bulbs, cable tightener and drilling template. All parts and elements can also be ordered separately. Installation height 230–250 cm. Maximum capacity of cables: 350 watts. Maximum cable length without additional ceiling fixture: 10 m. We can also supply custom-designed systems –



First photograph of YaYaHo, 1984

please ask for details. **Ya Ya Ho** est un système d'éclairage basse tension, relié à un transformateur (capacité maximum 200 watts) qui change les 230/125 volts en 12 volts. Tous les éléments sont mobiles horizontalement et quelque-uns en plus verticalement. Livré avec ampoule, gabarit de perçage et outils tendeurs. Chaque part et élément est également disponible individuellement. Hauteur de montage d'un système: 230 à 250 cm. Capacité maximum des câbles 350 watts. Longueur maximum des câbles sans utilisation d'une suspension plafond: 10 mètres. Planification et modèles hors série peuvent être réalisés sur demande. **Ya Ya Ho** è un sistema di luci a basso voltaggio, alimentato da un trasformatore (potenza 200 watt max.) che riduce 230/125 volt a 12 volt. Tutti gli elementi sono regolabili in orizzontale e alcuni anche in verticale. Forniti con lampadina, dima di foratura e utensili per il montaggio. Ogni part e ogni elemento sono disponibili anche singolarmente. Altezza di montaggio di un sistema: da cm. 230 a cm. 250. Carico massimo dei cavi 350 watt. Lunghezza massima dei cavi senza dispositivo di fissaggio al soffitto: 10 metri. Realizzazioni speciali e progettazione su richiesta.



#### Element 14

Silikon, Metall, Kunststoff. Auf den Seilen horizontal und vertikal beweglich. ■ Silicone, metal, plastic. Adjustable vertically and horizontally along the wires. ■ Silicone, métal, matière plastique. Mobile à l'horizontale et à la verticale sur les câbles métalliques. ■ Silicone, metallo, materiale sintetico. Mobile lungo i cavi in orizzontale e verticale.





New element No. 14 and No.16 for YaYa Ho in silicone.

### Element 16

Silikon, Metall, Kunststoff. Auf den Seilen horizontal beweglich. Leuchtenkopf schwenkbar. ■ Silicone, metal, plastic. Adjustable horizontally along the wires. Reflector unit swivels. ■ Silicone, métal, matière plastique. Mobile à l'horizontale sur les câbles métalliques. ■ Silicone, metallo, materiale sintetico. Elemento mobile lungo i cavi in orizzontale e verticale. Corpo illuminante rotante e basculante.

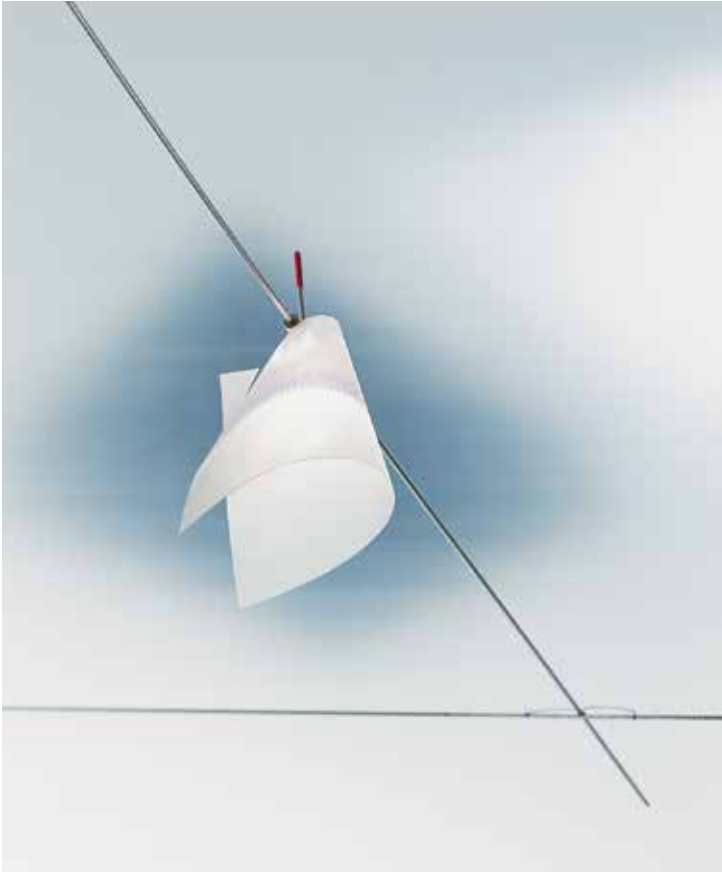

Element 6



Element 3

 Elem. 6, Elem. 3: 50 W 36° Halogen, 775 lm, 3000 K, 4000 h, EEC B

 GX 5,3, max. 50 W, A++-E

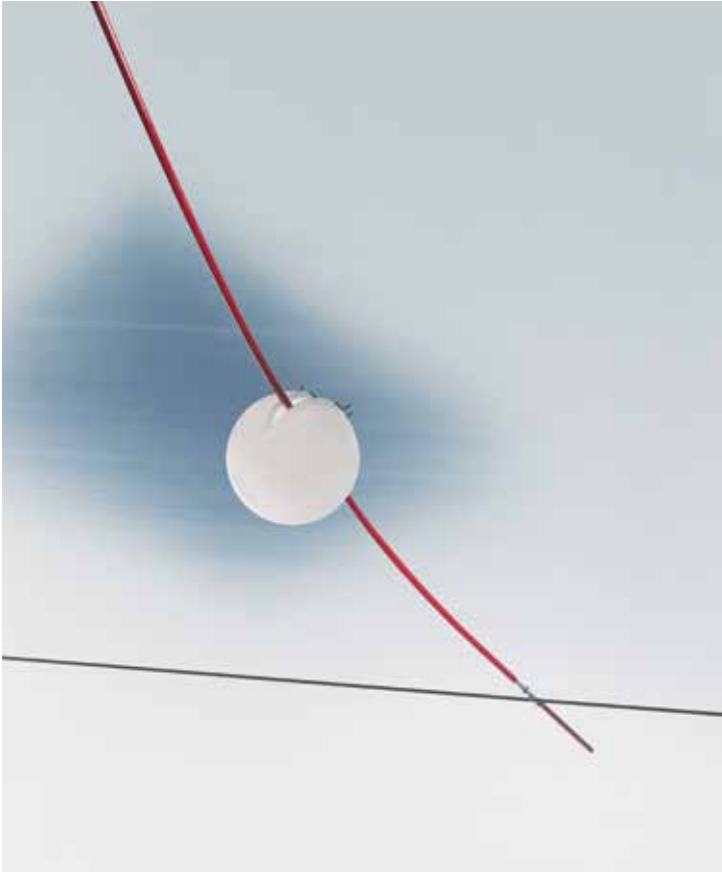

Element I



Element 77

-  Elem. I: 20 W Halogen, 300 lm, 2800 K, 4000 h, EEC C  G4, max. 20 W, B-E
-  Elem. 77: 50 W 36° Halogen, 775 lm, 3000 K, 4000 h, EEC B
-  GX 5,3, max. 50 W, A++-E



**Element 4 + 5**

### **Y&Y Ho Element 4, Element 5**

Auf den Seilen horizontal und vertikal beweglich. ■ Adjustable vertically and horizontally along the wires. ■ Mobile à l'horizontale et à la verticale sur les câbles métalliques.  
 ■ Mobile lungo i cavi in orizzontale e verticale.

### **Element 6, Element 3**

Multi Mirror-Reflektor. Auf den Seilen horizontal beweglich, Leuchtenkopf schwenkbar.  
 ■ Multi-Mirror reflector. Adjustable horizontally along the wires, reflector unit swivels.  
 ■ Réflecteur Multi Mirror. Mobile à l'horizontale sur les câbles métalliques. La tête du luminaire est pivotante/rotative. ■ Riflettore Multi Mirror. Elemento mobile lungo i cavi in orizzontale e verticale. Corpo illuminante rotante e basculante.

### **Element 1**

Auf den Seilen horizontal beweglich. ■ Adjustable horizontally along the wires. ■ Mobile à l'horizontale sur les câbles métalliques. ■ Elemento mobile lungo i cavi in orizzontale.

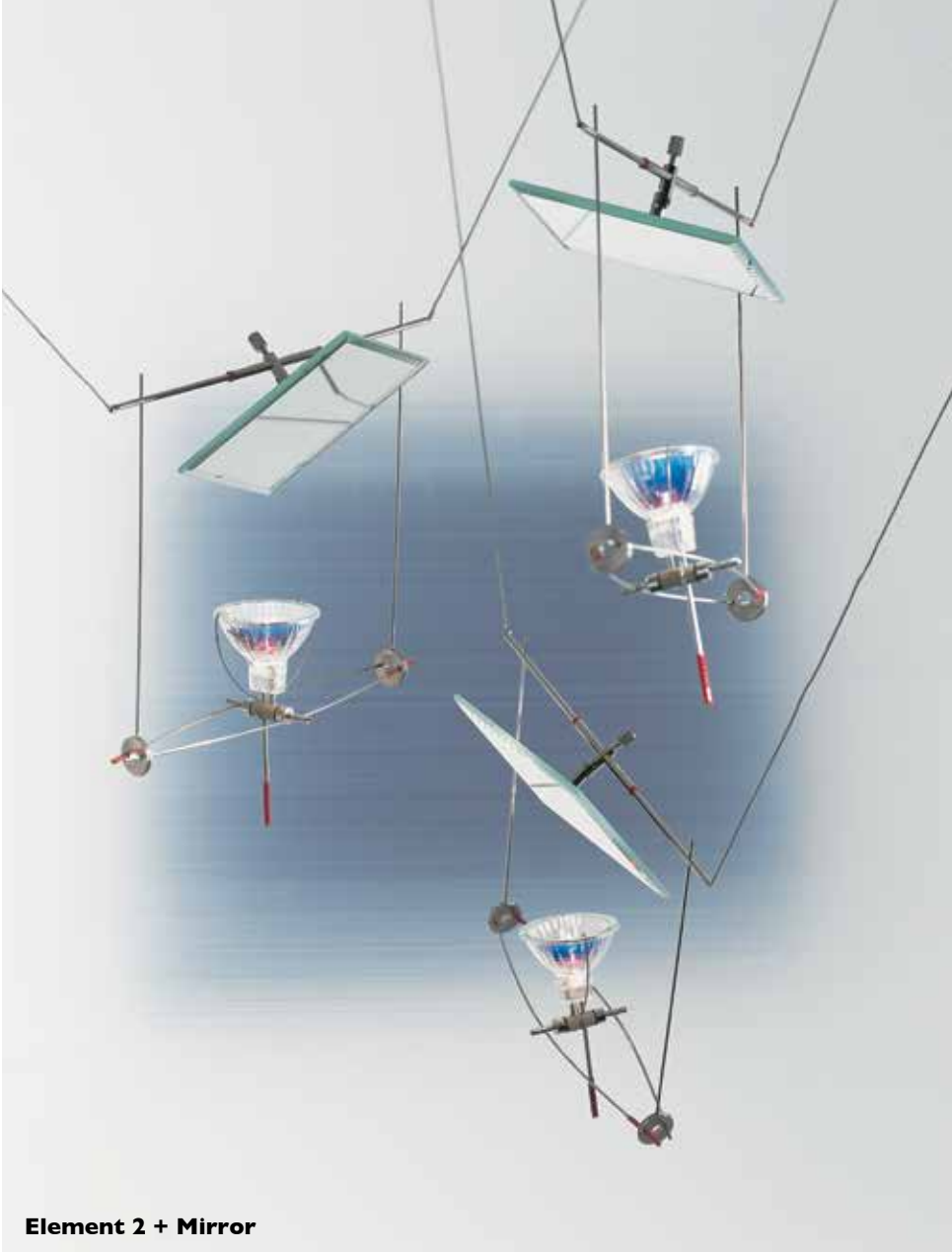

**Element 2 + Mirror**

### **Element 2 + Spiegel / Mirror / Miroir / Specchio**

Multi Mirror-Reflektor. Auf den Seilen horizontal und vertikal beweglich. Leuchtenkopf schwenkbar. Lieferbar auch ohne Spiegel. ■ Multi-Mirror reflector. Adjustable vertically and horizontally along the wires. Reflector unit swivels. Also available without mirror. ■ Réflecteur Multi Mirror. Mobile à l'horizontale et à la verticale sur les câbles métalliques. La tête du luminaire est pivotante/rotative. Egalement disponible sans miroir. ■ Riflettore Multi Mirror. Mobile lungo i cavi in orizzontale e verticale. Corpo illuminante rotante e basculante. Disponibile anche senza specchio.

### **Element 77**

Multi Mirror-Reflektor. Auf den Seilen horizontal und vertikal beweglich. Leuchtenkopf schwenkbar. ■ Multi-Mirror reflector. Adjustable vertically and horizontally along the wires. Reflector unit swivels. ■ Réflecteur Multi Mirror. Mobile à l'horizontale et à la verticale sur les câbles métalliques. La tête du luminaire est pivotante/rotative. ■ Riflettore Multi Mirror. Mobile lungo i cavi in orizzontale e verticale. Corpo illuminante basculante.

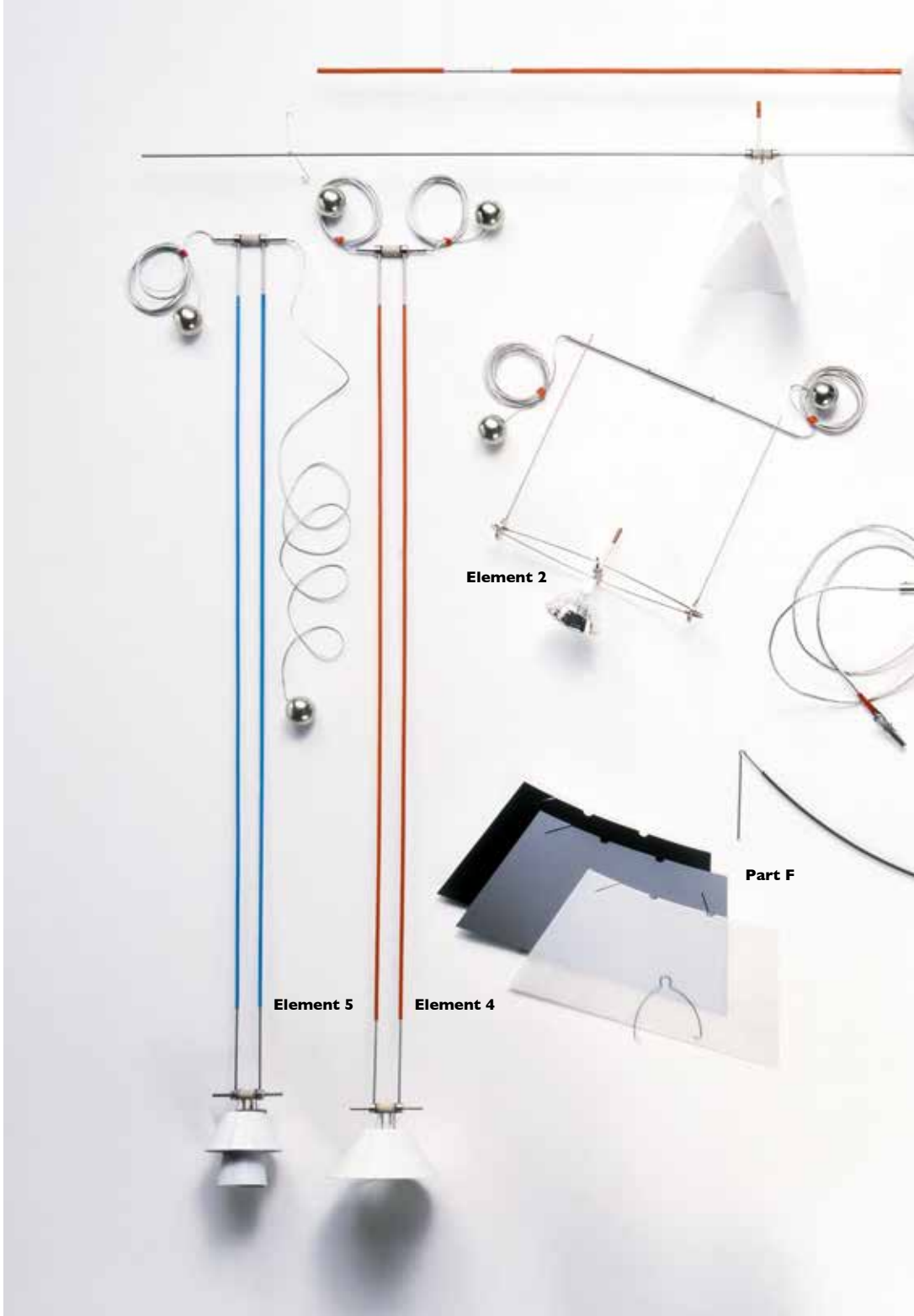

**Ya Ya Ho** besteht aus **Parts** und **Elementen**, die einzeln verfügbar sind. Für individuelle Zusammenstellung. Wichtig zu beachten: Gebrauchsanweisung und Gesamtwattzahl.

**Ya Ya Ho** is composed of **Parts** and lighting **Elements**, which are separately available. For unique configurations. Important: Study mounting instructions and observe total wattage.

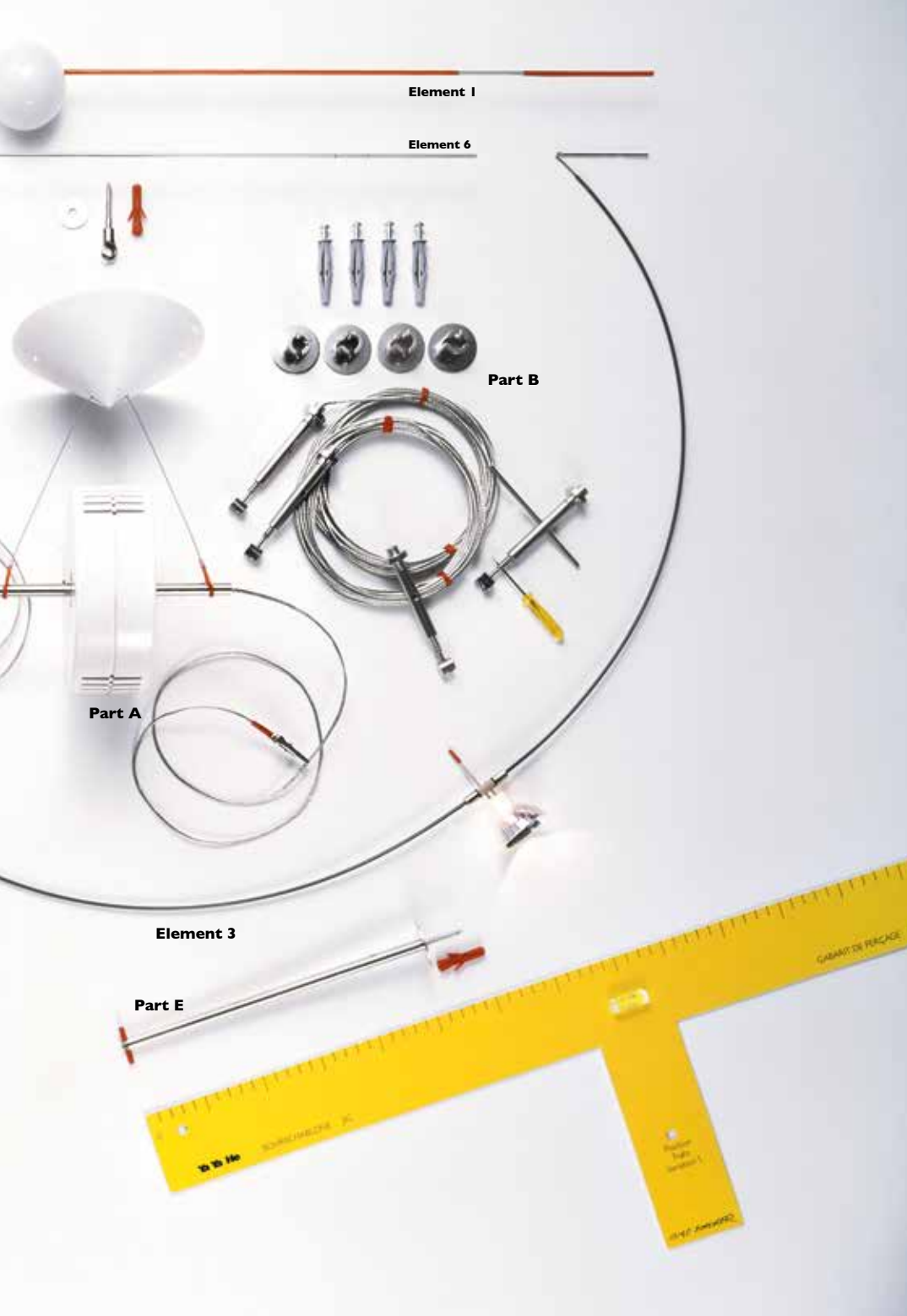

**Ya Ya Ho** est composé de **Parts** et d'**Eléments**, qui sont disponibles séparément. Pour compositions individuelles. Important: observer attentivement les instructions de montage et le nombre total de watts.

**Ya Ya Ho** consiste in **Parti** ed **Elementi**, disponibili separatamente. Per soluzioni individuali. Importante: Seguire esattamente le istruzioni di montaggio e osservare la potenza massima consentita.

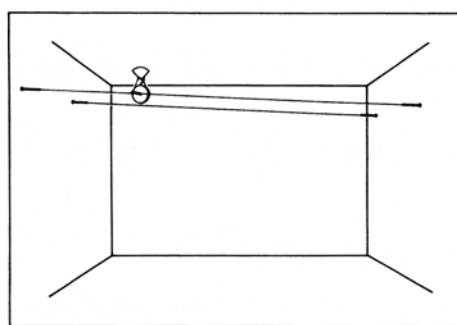
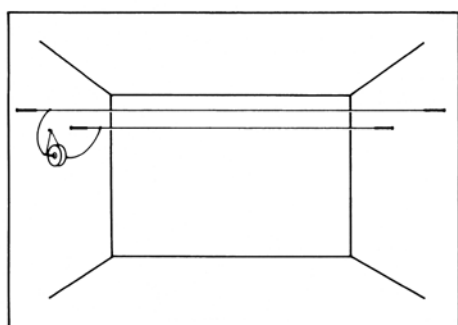
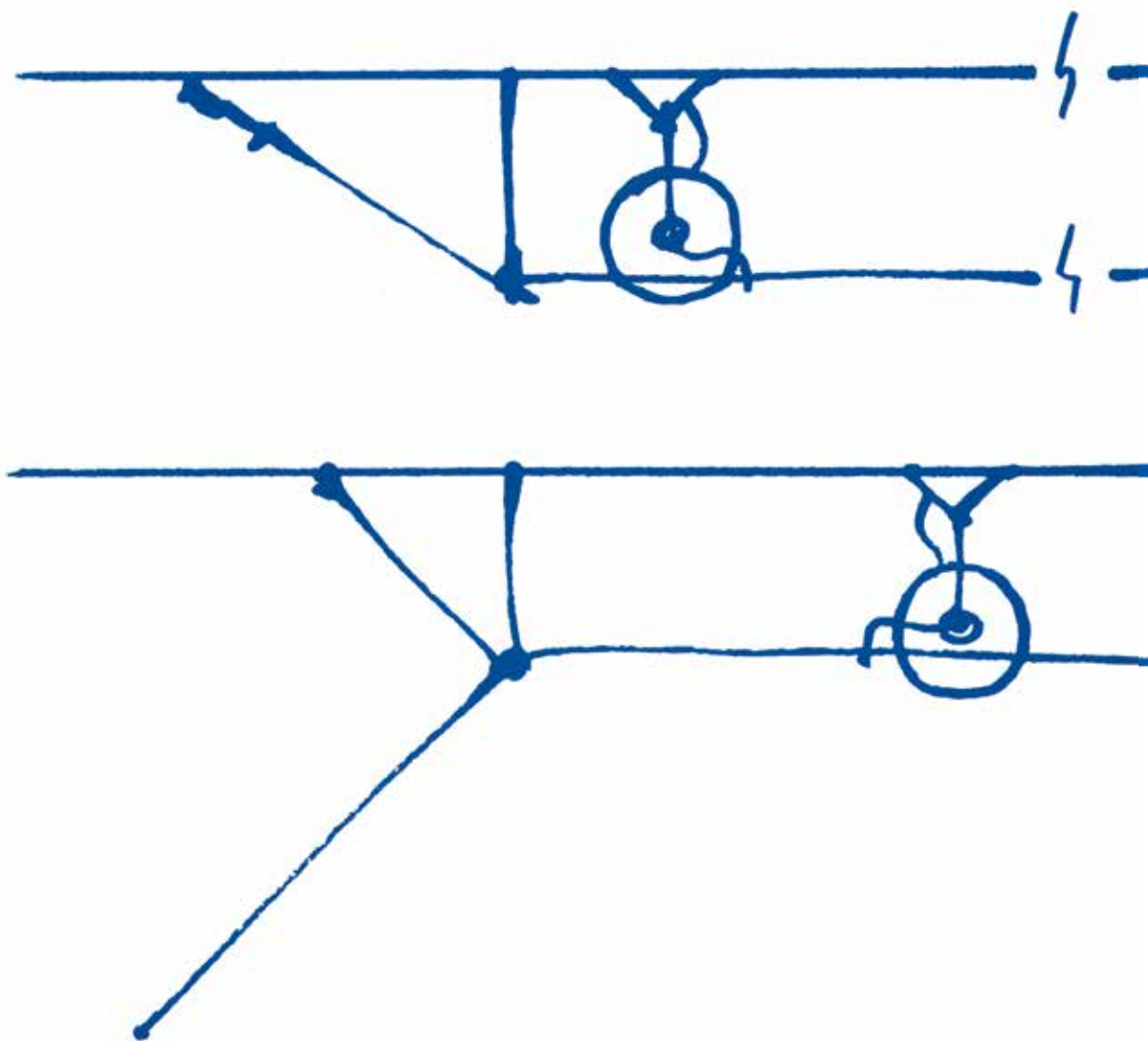

**Ya Ya Ho** lässt sich von der Decke und auch über Eck abspannen. Durch Verwendung von Isolierteilen können Sie die Länge des Systems erweitern, und mit einem zweiten Transformator kann die Anzahl der Lichtelemente erhöht werden.

**Ya Ya Ho** can also be installed on ceilings or in corners. Insulators can also be used to extend the length of the system, and a second transformer may be added to increase the number of lighting elements.



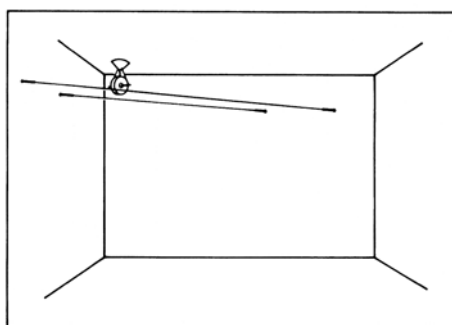
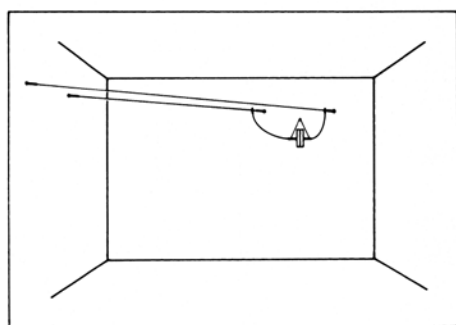
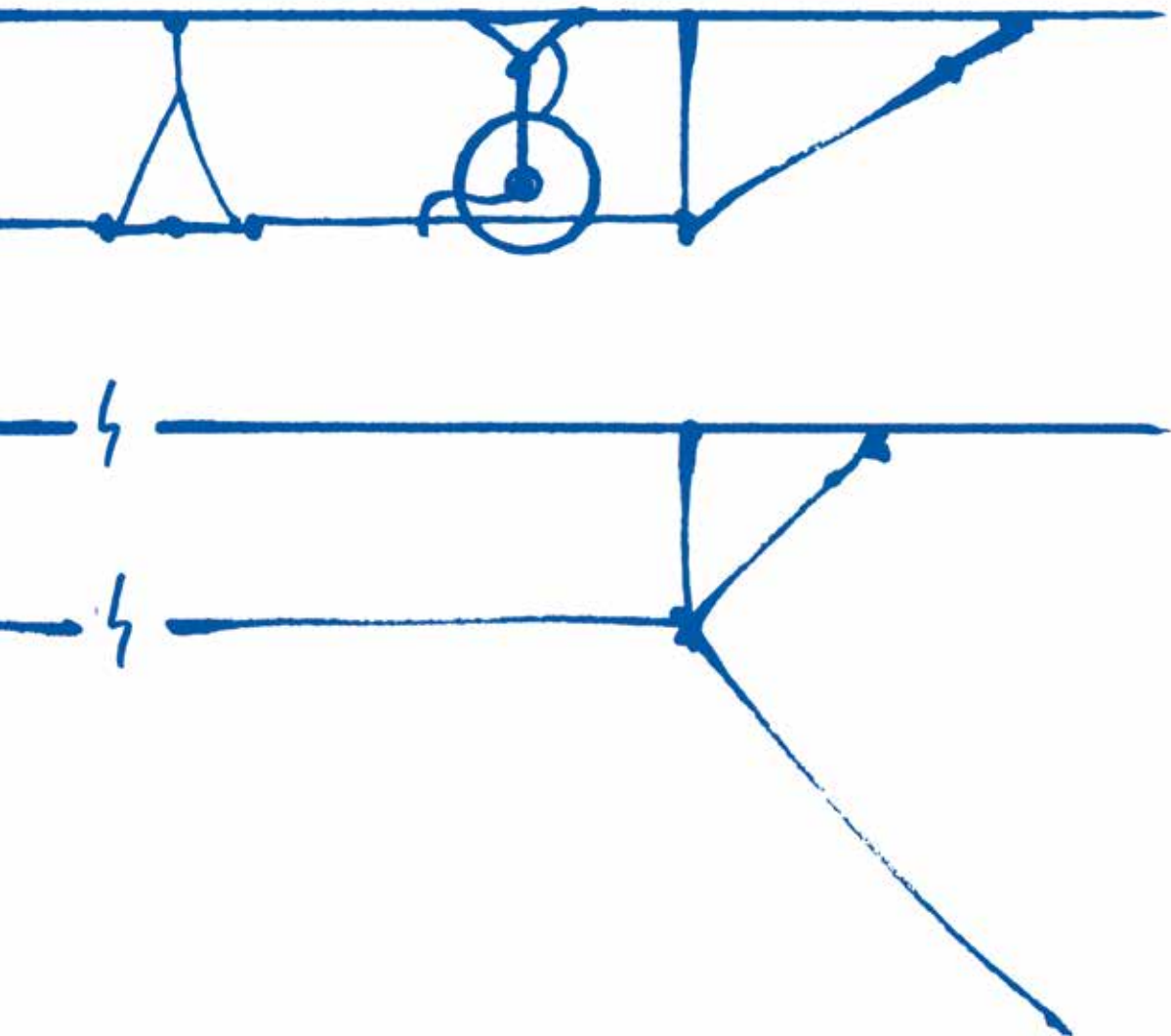

**Ya Ya Ho** se fixe au plafond et également en coin. L'emploi des parties isolatrices permet d'augmenter la longueur du système et un deuxième transformateur d'augmenter le nombre des éléments lumineux.

**Ya Ya Ho** può essere installato a soffitto oppure ad angolo. Utilizzando isolatori è possibile aumentare la lunghezza del sistema, e un secondo trasformatore consente di ampliare la quantità di elementi illuminanti.



**Ya Ya Ho** Ingo Maurer und Team 1984

**Part A:** Transformator weiß mit 230/125-Volt-Zuleitung mit Schalter; für Wand- und Deckenmontage. **Part B:** 2 Spezialseile à 6, 8 oder 10 Meter; 4 Wandbefestigungen mit isolierten Spannschlössern, geeignet zur Montage auch auf leitenden Materialien. **Part D:** 2 x 2 Spezialseile à 6, 8 oder 10 Meter; 4 Wandbefestigungen mit isolierten Spannschlössern sowie zwei Isoliereinheiten und Deckenabhängung; für beide Teillängen wird je ein Transformator benötigt. **Part E:** Metallstäbe mit 25,5 cm Länge für Deckenabspannung oder Über-Eck-Spannung der Spezialseile. **Part F:** Blenden für Lichtelemente 2, 3 und 6. Naturfarben, Schwarz.

**Part A:** Transformer white, with 230/125-volts lead and switch, for wall or ceiling installation. **Part B:** 2 special cables (length 6, 8 or 10 m), 4 wall anchors with insulated tensioning bolts, attachable to any kind of surface including conductive materials. **Part D:** 2 pairs of special cables (length 6, 8 or 10 m), 4 wall anchors with insulated tensioning bolts, 2 insulators, ceiling fixture; separate transformer required for each pair of cables. **Part E:** Nickel-plated metal rods, length 25,5 cm, for ceiling or corner installation. **Part F:** Shades for lighting elements 2, 3 and 6. Colours: natural, black.



**Part A:** transformateur blanc avec câble d'alimentation 230/125 volts et interrupteur pour le montage au mur ou au plafond. **Part B:** 2 câbles spéciaux d'une longueur de 6, 8 ou 10 m, 4 fixations murales avec tendeurs isolés permettant également un montage sur matériaux conducteurs. **Part D:** 2 x 2 câbles spéciaux d'une longueur de 6, 8 ou 10 m, 4 fixations murales avec tendeurs isolés et également deux unités d'isolation et suspension plafond; chaque paire de câbles nécessitant un transformateur. **Part E:** tiges en métal nickelé d'une longueur de 25,5 cm pour fixation des câbles spéciaux soit au plafond soit en coin. **Part F:** écrans résistant à la chaleur s'adaptant sur les éléments 2, 3 et 6. De couleur naturelle, noire.

**Part A:** Trasformatore bianco con alimentazione 230/125 volt con interruttore, per montaggio a parete o a soffitto. **Part B:** 2 cavi speciali di 6, 8 oppure 10 metri, 4 attacchi murali con tiranti isolati che consentono il montaggio anche su materiali conduttori. **Part D:** 2 x 2 cavi speciali di 6, 8 oppure 10 metri. 4 attacchi murali con tiranti isolati, compresi due isolatori e dispositivo di fissaggio a soffitto. Per entrambi i tratti di cavo è necessario un trasformatore. **Part E:** Aste metalliche nichelate di lunghezza cm. 25,5 per montaggio dei cavi speciali a soffitto oppure ad angolo. **Part F:** Schermi termoresistenti per gli elementi illuminanti 2, 3 e 6. Disponibili nei colori naturale e nero.



Défilé Issey Miyake, La Villette/Paris



Symphonia Silenziosa, light installation

A composition of custom-made and standard YaYaHo parts has been realized for several exhibitions including an Issey Miyake fashion show in Paris, 1999.

**What did we  
do with halogen  
lighting?**

We stripped it to its bones, respecting function and aesthetics, avoiding visual noise, adding formal expression, thus becoming birds, moons, flying somethings, on wires. Plagiarists have never understood what we did.

**Qu'avons-nous  
fait avec l'éclairage  
halogène?**

Nous l'avons dénudé jusqu'à l'os, en respectant la fonction et l'esthétique, en évitant le bruit visuel, en ajoutant une expression formelle, le transformant ainsi en oiseaux, lunes, objets volants sur des fils. Les plagiaires n'ont jamais compris ce que nous avons fait.

**Cosa abbiamo fatto  
con l'illuminazione  
alogeno?**

L'abbiamo ridotta all'essenziale, rispettando funzionalità ed estetica, evitando disarmonie, aggiungendo nuove forme e quindi creato uccelli, lune ed altri oggetti che volano sui cavi. I plagiaristi non l'hanno mai compreso.

**Was haben wir mit  
Halogenbeleuchtung  
getan?**

Wir reduzierten auf das Notwendigste, haben Funktion und Ästhetik im Auge behalten, visuellen Nonsense vermieden, Formen hinzugefügt und damit Vögel, Monde und andere fliegende Objekte auf Seilen geschaffen. Unsere Plagiatoren haben das nie begriffen.

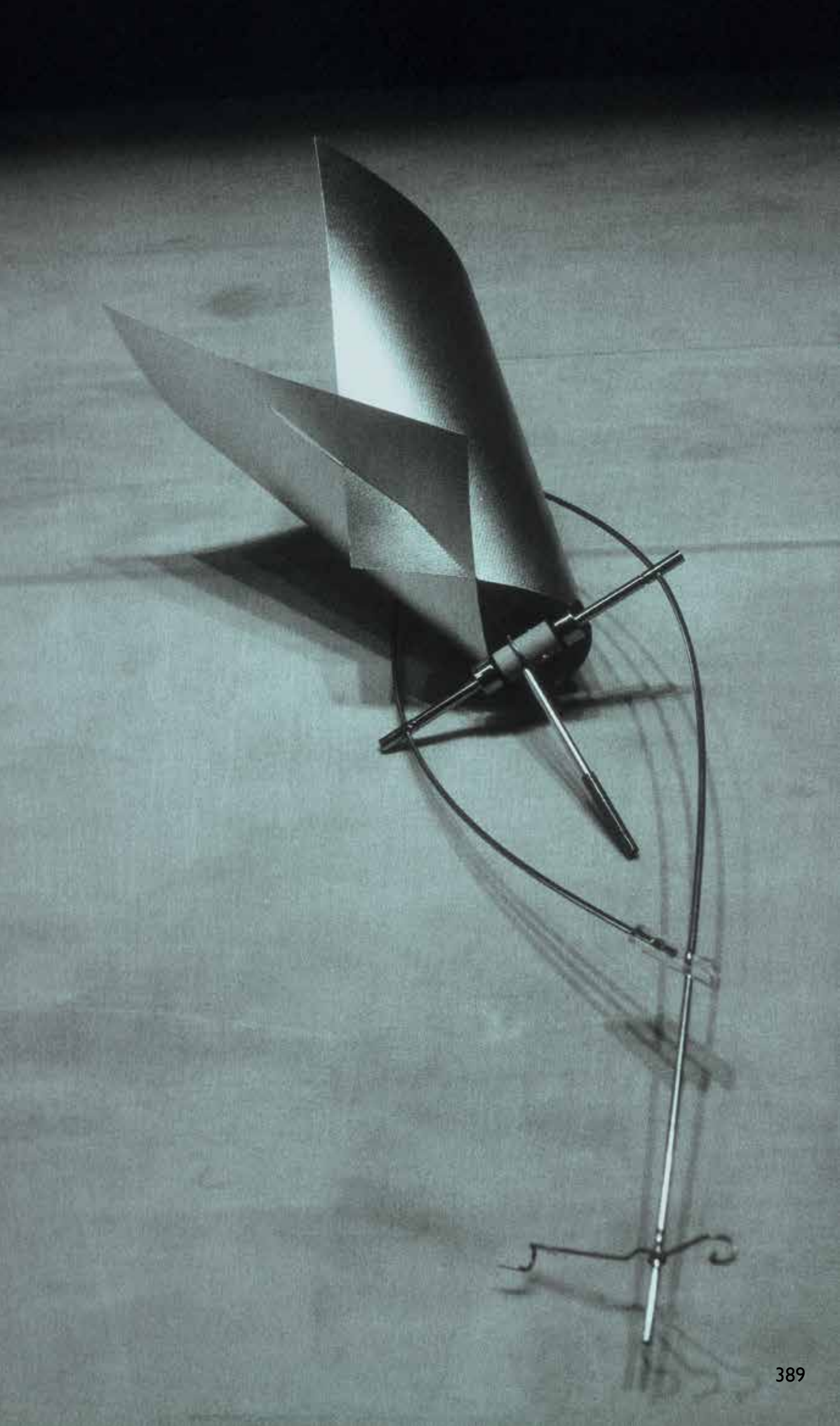



**BaKa RÚ** Design: Ingo Maurer und Team 1986

**BaKa RÚ** ist ein Niedervolt-Lichtsystem und wird über einen Transformator betrieben, der 230/125 Volt auf 12 Volt reduziert. Der Transformator ist mit einer Thermo-sicherung ausgestattet. Er ist bis max. 200 Watt belastbar.

Kunststoff, Metall, Keramik, Multi Mirror-Reflektoren mit Schutzglas. Lieferung mit hitze-beständigen naturfarbenen Blenden, Leuchtmitteln, Bohrschablone und Spannwerkzeug. Die Lichtelemente lassen sich in jede Richtung drehen und auf den Seilen verschieben. Durch die isolierten Spanschlösser ist die Montage auch auf leitenden Materialien mög-lich. Die Spezialseile können in einer Länge von 6, 8 oder 10 Metern geliefert werden. Bei größeren Distanzen wird ein zweiter Transformator mit den erforderlichen Isolier-einheiten empfohlen. Maximale Belastbarkeit der Seile 350 Watt. Schwarze Blenden erhältlich. Lichtsteuerung nur über Spezialdimmer für Trafobetrieb. BaKaRú lässt sich von Wand zu Wand spannen oder an die Decke montieren. Waagerechte, senkrechte oder auch diagonale Installation ist möglich.

 50 W 36° Halogen, 775 lm, 3000 K, 4000 h, EEC B

 GX 5,3, max. 50 W, A++-E, external transformer 230/125/12 V





**BaKa...Rú** is a low-voltage lighting system fed by a transformer which reduces the 230/125-volt mains current to 12 volts. The transformer (max. capacity 200 watts) is fitted with a thermal fuse.

Plastic, metal, ceramic, Multi-Mirror reflectors with protective glass cover. Complete with heat-resistant shades (colour: natural), bulbs, drilling template and cable-tautener. The lighting elements can be moved along the cables and turned in any direction. The insulated tensioning bolts make it possible to install the system on any surface, including conductive materials. The special cables can be supplied in lengths of 6, 8 or 10 m. For longer cables the use of a second transformer (with the necessary insulators) is recommended. Maximum capacity of cables: 350 watts. Shades in black are available. N.B. the dimmer (if any) must be specially adapted for halogen lighting. BaKaRú is equally suitable for wall or ceiling installation. It can be mounted horizontally, vertically or even on the diagonal.



**BaKa...Rú** est un système d'éclairage basse tension, relié à un transformateur qui change les 230/125 volts en 12 volts. Le transformateur est équipé d'un fusible thermo-électrique. La capacité maximum du transformateur est de 200 watts.

Matière plastique, métal, céramique; réflecteurs Multi Mirror avec verre protecteur. Livré avec des écrans de couleur naturelle résistant à la chaleur, ampoules, gabarit de perçage et tendeurs. Les éléments lumineux sont orientables dans toutes les directions et peuvent être déplacés sur les câbles. Les tendeurs isolants permettent même un montage sur des matériaux conducteurs. Les câbles spéciaux sont livrés dans les longueurs de 6, 8 ou 10 mètres. Pour des distances plus grandes, l'utilisation d'un deuxième transformateur avec les parties isolantes nécessaires est recommandée. Capacité maximum des câbles 350 watts. Ecrans noirs disponibles. Réglage de l'intensité lumineuse uniquement par un variateur spécial pour lampe halogène. BaKaRú se tend de mur à mur ou au plafond. Le système se monte à l'horizontale, mais également à la verticale ou même en diagonale.

**BaKa...Rú** è un sistema di luci a basso voltaggio, alimentato da un trasformatore che riduce 230/125 volt a 12 volt. Il trasformatore è dotato di una sonda termica. Carico massimo consentito del trasformatore 200 watt.

Materiale sintetico, metallo, ceramica; riflettori Multi Mirror con vetro di protezione. Fornito con schermi termoresistenti di colore naturale, lampadine, dima di foratura e utensili per il montaggio. Gli elementi sono orientabili in ogni direzione e possono essere spostati sui cavi. I tiranti isolati consentono il montaggio anche su materiali conduttori. I cavi speciali sono disponibili nelle lunghezze di 6, 8 e 10 metri. In caso di distanze superiori, è consigliato l'impiego di un secondo trasformatore con l'utilizzo di isolatori. Carico massimo dei cavi 350 watt. Sono disponibili schermi di colore nero. Regolazione della luce esclusivamente mediante uno speciale varialuce per lampade alogene. BaKaRú può essere teso da parete a parete o montato a soffitto. E' possibile un'installazione orizzontale, verticale o diagonale.

 **50 W 36° Halogen, 775 lm, 3000 K, 4000 h, EEC B**

 **GX 5,3, max. 50 W, A++-E, external transformer 230/125/12 V**

Technische und formale Änderungen vorbehalten. Unsere Website bietet weitere Fotos, Skizzen und aktuelle Informationen. Die in diesem Katalog gedruckten Farben können von den tatsächlichen Farben der Lampen abweichen. Wir führen ein großes Spektrum von Ersatzteilen für unsere Produkte. Bitte wenden Sie sich an Ihren lokalen Händler, die zuständige Vertretung oder direkt an die Ingo Maurer GmbH.

We reserve the right to all make technical or aesthetic modifications. Our website offers more images and detailed up-to-date information. Please allow for colour discrepancies between the illustrations in this catalogue and the actual products. We carry a large range of spare parts for our products. Please contact your local dealer, your agency or Ingo Maurer GmbH.

Sous réserve de modifications techniques et de forme. Notre site internet vous propose davantage de photos, d'esquisses et d'informations détaillées et actuelles. Les couleurs imprimées dans ce catalogue peuvent varier des couleurs réelles des lampes. Nous avons une grande variété de pièces détachées pour nos produits. Veuillez contacter votre revendeur local, votre agent ou la société Ingo Maurer GmbH directement.

Salvo modifiche di carattere tecnico o formale. Il nostro sito offre ulteriori fotografie, dettagli e informazioni aggiornate. I colori riprodotti nel catalogo possono differire dai colori reali delle lampade. Offriamo una vasta gamma di ricambi per i nostri prodotti. Per informazioni rivolgersi al vostro rivenditore locale, al vostro agente oppure direttamente alla Ingo Maurer GmbH.

Geschäftsleitung:	Simone Sinhuber
Ingo Maurer	Hana Stauss
Claude Maurer	Zorka Stosic
Joachim Moyzischewitz	Flavia Thumshirn
Angela Wilhelm	Evangelia Tsaoussi
	Sebastian Utermöhlen
	Isagani Vengco
Design, Entwicklung, Planung, Produktion, Vertrieb:	Jenny Weber
	Regina Wilhelm
Ralf Altermann	Angelika Wipf
Viktor Antonijevic	Eugen Wronek
Till Armbrüster	
Mariya Babalakova	
Peter Berson	
Werner Berthold	
Albert Brandmair	
Reinhold Brandmair	
Winfried Brecheler	
Marilyn O. F. Cassidy	
Silvia Catanese	
Sylvie Chevalier	
Birget Daenell	
Maxwell Deutsch	
Heike Dewald	
Stella Doerner	
Gertraud Eisenreich	
Petra Fleissner	
Thomas Fröhlich	
Angela Guevara	
Rudi Gundel	
Thomas Happel	
Haki Haxhiu	
Sebastian Hepting	
Elke Herpich	
Marion Kaindl	
Manfred Kaiser	
Friederike Klesper	
Christa Kolenc	
Gabi Kümmerlin	
Helmut Lange	
Vassilios Lianos	
Matthias Liedtke	
Dimitra Lionda	
Eveline Lotteraner	
Eric McNeil	
Maria Mettke	
Thomas Mettler	
Daniel Michel	
Elvira Müllerleile	
Ivica Nestic	
Petra Obermaier	
Cveta Pesevska	
Manuela Pesevska	
Tobias Reischle	
Bernd Schäfer	
Axel Schmid	
Oswald Schneider	
Hagen Sczech	
Michel Sempels	

Photographie:

Tom Vack, Milano

Studio Azzurro, Milano

Nomi Baumgartl, München

Antoine Bootz, New York

Stefan Büchner, Hahnbach

Hans Buttermilch, München

Peter Cook, London

Domus, Milano – Donato di Bello

Bernhard Dessecker, München

Robert Fischer, München

Friederike Klesper, München

Eric Laignel, New York

Tim Lehrmacher, New York

Giovanna Piemonte, Rom

Christof Piepenstock, München

Jonathan B. Ragle, New York

Hagen Sczech, München

Markus Tollhopf, Hamburg

Sebastian Utermöhlen, München

Peter Wachowich, Vancouver

Cover Illustration:

Axel Schmid

Grafik Design/Realisierung:

Frank Koschembar / [www.gute-kommunikation.com](http://www.gute-kommunikation.com)

Druck:

Druckerei Vogl GmbH & Co. KG, Zorneding

Bildbearbeitung/Compositing:

Stefan Geisbauer, [red-light-design.com](http://red-light-design.com)

Ingo Maurer GmbH

Kaiserstrasse 47

80801 München

Tel. +49 89 381 6060

Fax +49 89 381 606 20

[info@ingo-maurer.com](mailto:info@ingo-maurer.com)

Ingo Maurer LLC

89 Grand Street

New York, NY 10013

Tel. 212 965 8817

Fax 212 965 8819

[making-light@ingomaurer-usa.com](mailto:making-light@ingomaurer-usa.com)

[www.ingo-maurer.com](http://www.ingo-maurer.com)

# INGO MAURER JETZT



INGO MAURER